SECTION 90

BUMPERS AND FASCIAS

TABLE OF CONTENTS

Description and Operation	90-2	On-Vehicle Service	90-4
Bumpers	90-2	Front Bumper Fascia	90-4
Component Locator	90-3	Front Bumper Impact Bar	90-5
Bumpers and Fascias	90-3	Rear Bumper Fascia	90-6
Repair Instructions	90-4	Rear Bumper Bracket	90-8

DESCRIPTION AND OPERATION

BUMPERS

The bumper systems are installed with the body color bumper and the general bumper according to the vehicle grade.

The bumper systems are designed to sustain a collision into a fixed barrier at 4 km/h (2.5 mph) without damage. After absorbing the energy of a collision, these bumper

systems restore themselves to their original position. Both the front and the rear bumpers feature an internal foam energy absorber and a polymer fascia cover. The front bumper consists of the bumper fascia and the impact bar. Remove the fascia before removing the impact bar. The rear bumper consists of the bumper fascia and the bracket. Removal of rear bumper brackets can be possible without removing the bumper fascia.

COMPONENT LOCATOR

BUMPERS AND FASCIAS

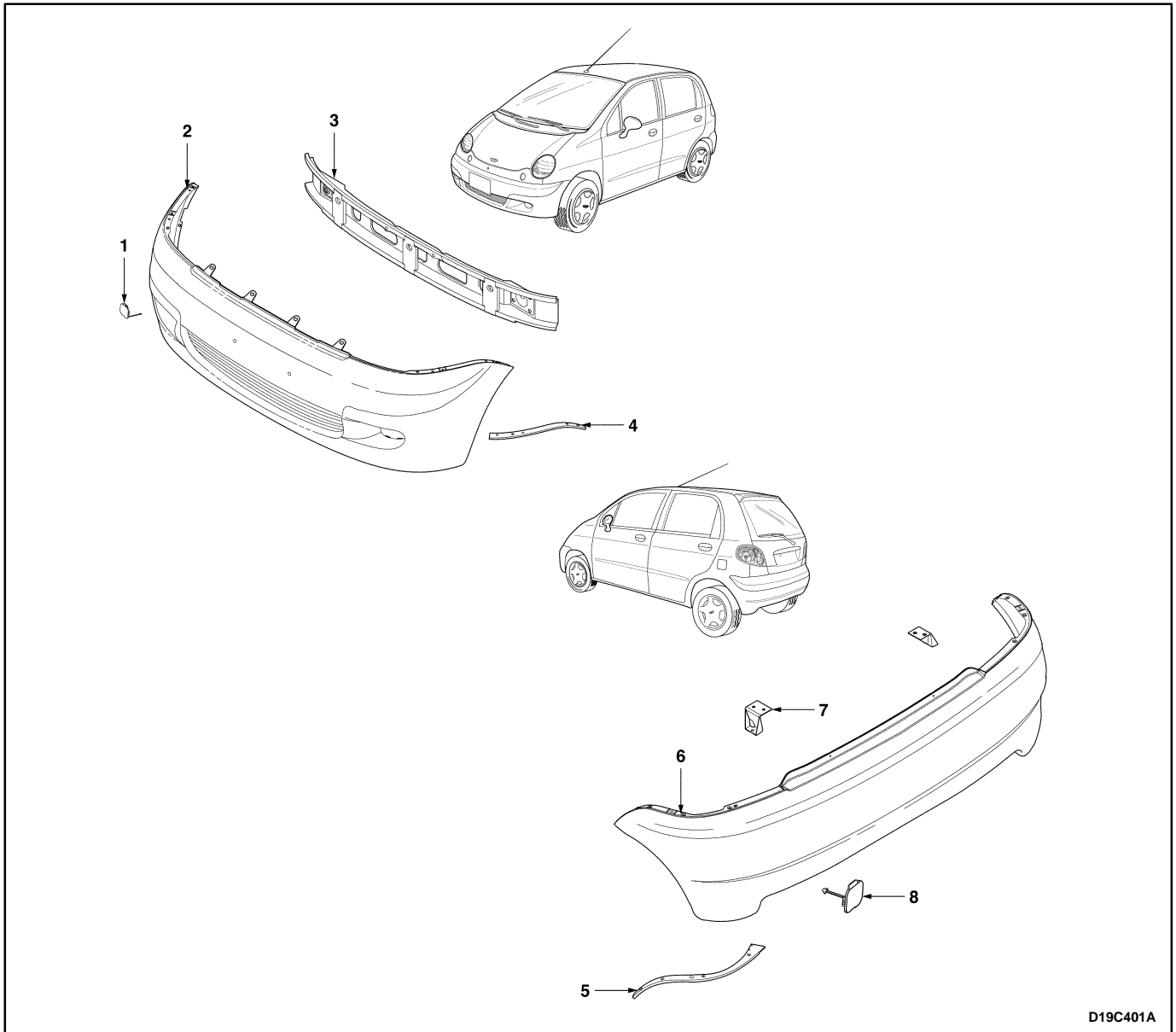

D19C401A

1. Front Towing Cover
2. Front Bumper
3. Front Bumper Impact Beam
4. Front Bumper Reinforcement

5. Rear Bumper Reinforcement
6. Rear Bumper
7. Rear Bumper Bracket
8. Rear Towing Cover

REPAIR INSTRUCTIONS

ON-VEHICLE SERVICE

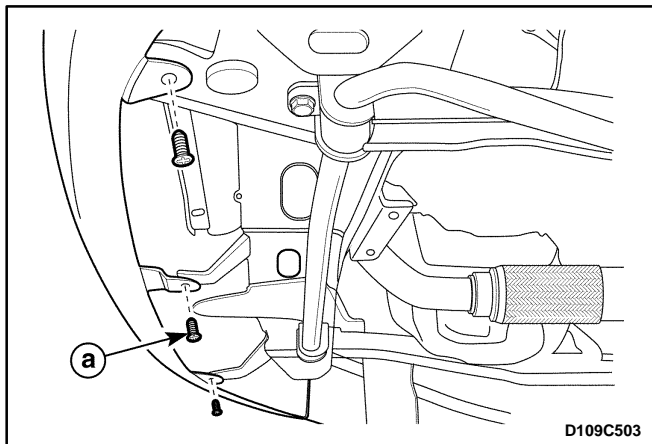
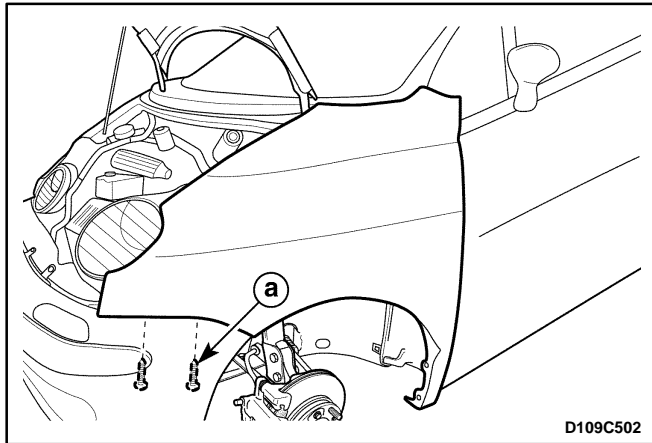
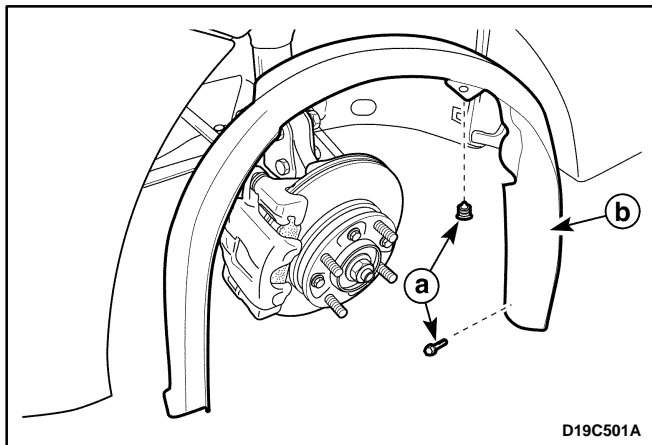

FRONT BUMPER FASCIA

Removal Procedure

1. Disconnect the negative battery cable.
2. Raise and suitably support the vehicle.
3. Remove the front wheels.
4. Remove the front wheel house splash shields.
 - Remove the clip and bolts.
 - a. Bolt and clip.
 - Remove the wheel house splash shield.
 - b. Splash shield.
5. Remove the bolts on the both side of the fascia.
 - a. Bolt.

6. Remove the clips under the fascia.
 - a. Clip.

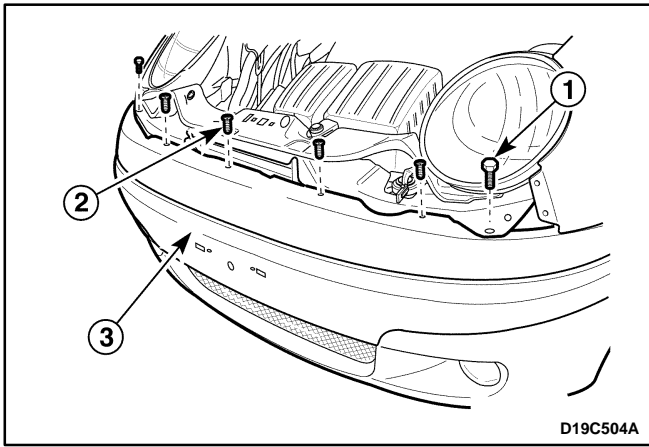

D19C504A

7. Lower the vehicle.
8. Remove the front bumper spacer from the bumper. Refer to *Section 9M, Exterior Trim*.
9. Remove the front bumper fascia.
 - Remove the bolts (1).
 - Remove the clips (2).
 - Remove the front bumper fascia (3).
10. Remove the front fog lamps. Refer to *Section 9B, Lighting Systems*.

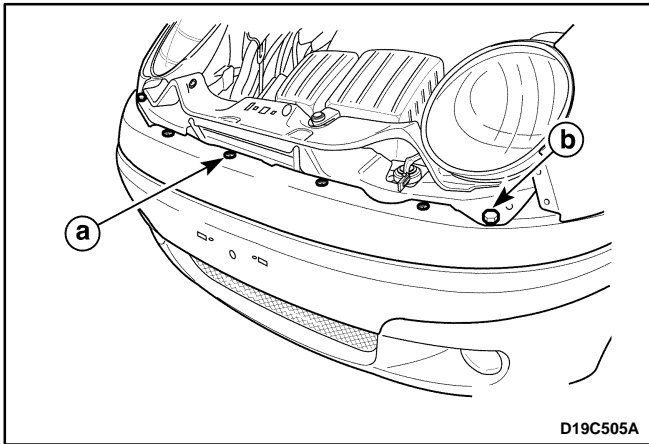

D19C505A

Installation Procedure

Notice: Dissimilar metals in direct contact with each other may corrode rapidly. Make sure to use the correct fasteners to prevent premature corrosion.

1. Install the front fog lamps. Refer to *Section 9B, Lighting Systems*.
2. Install the bumper fascia.
3. Install the clips on the top of the fascia.
 - a. Fascia upper clip.
4. Install the bolts on the top of the fascia.
 - b. Fascia upper bolt.
5. Install the front bumper spacer. Refer to *Section 9M, Exterior Trim*.

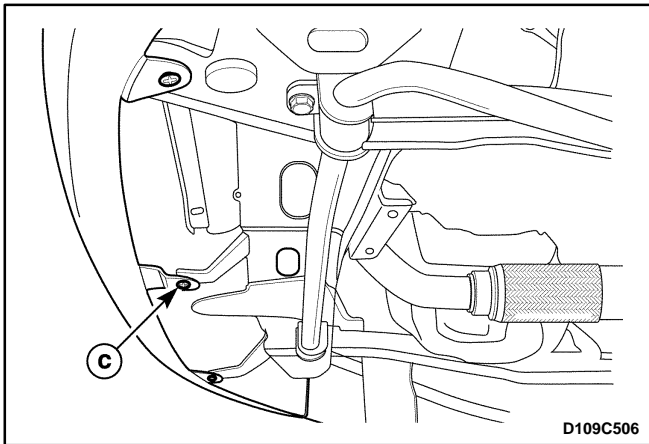

D109C506

6. Raise and suitably support the vehicle.
7. Install the clips under the fascia.
 - c. Fascia lower clip.
8. Install the bolts on the both side of the fascia.
9. Install the front wheelhouse splash shields with the clips and the bolts.
10. Install the front wheels.
11. Lower the vehicle.
12. Connect the negative battery cable.

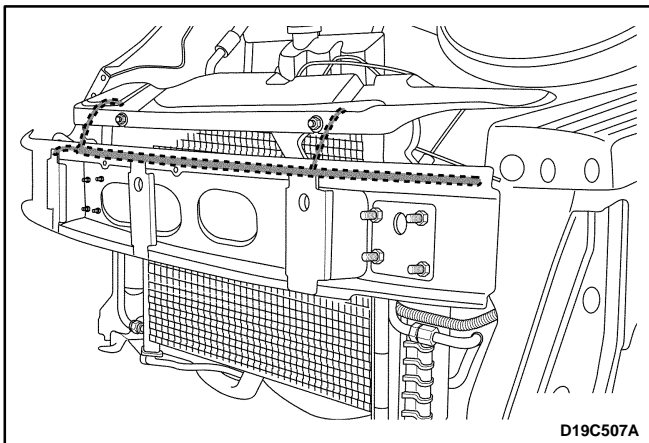

D19C507A

FRONT BUMPER IMPACT BAR

Removal Procedure

1. Disconnect the negative battery cable.
2. Remove the front bumper fascia. Refer to "Front Bumper Fascia" in this section.
3. Remove the front wiring harness retaining clip from the impact bar.

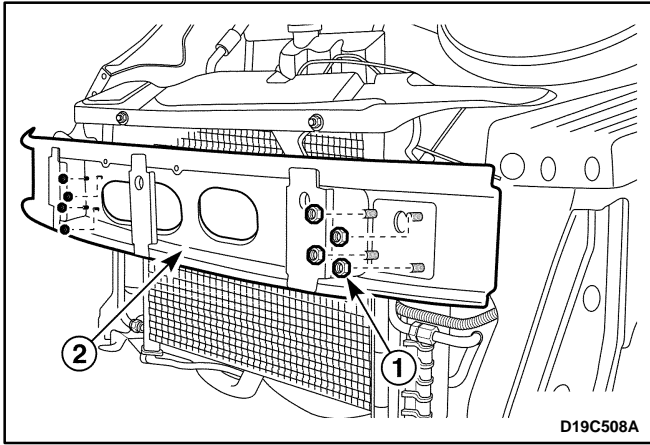

3. Remove the impact bar.
 - Remove the nuts (1).
 - Remove the impact bar (2).

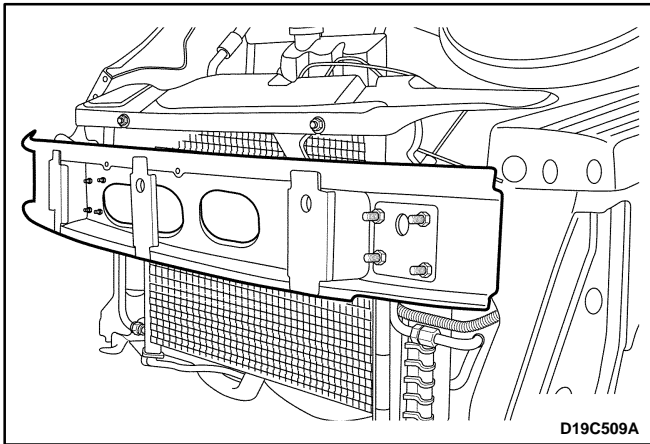

Installation Procedure

Notice: Dissimilar metals in direct contact with each other may corrode rapidly. Make sure to use the correct fasteners to prevent premature corrosion.

1. Install the impact bar with the nuts.

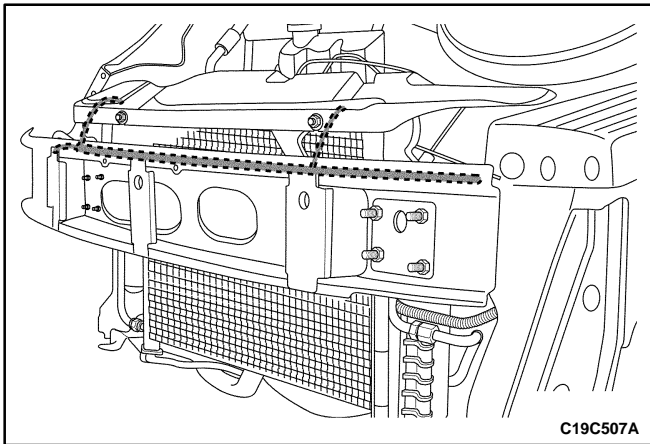

2. Install the front wiring harness retaining clip to the impact bar.
3. Install the front bumper fascia. Refer to "Front Bumper Fascia" in this section.
4. Connect the negative battery cable.

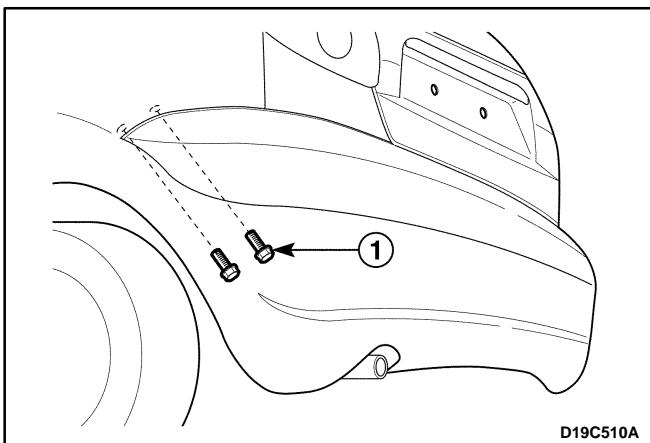

REAR BUMPER FASCIA

Removal Procedure

1. Raise and suitably support the vehicle.
2. Remove the bolts underneath the fascia.
 - Remove the bolts (1).

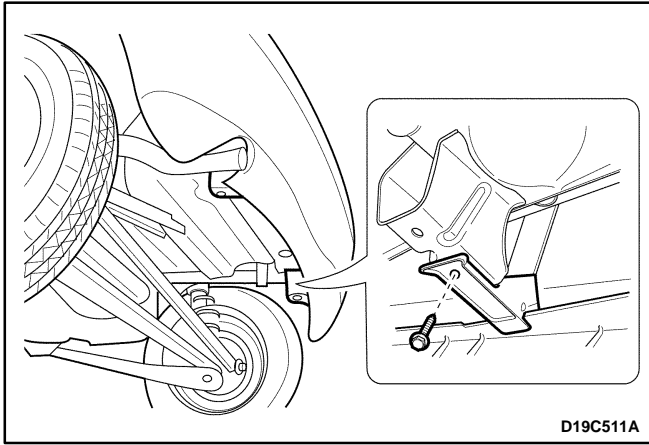

3. Remove the fascia bolts from the rear bumper bracket.

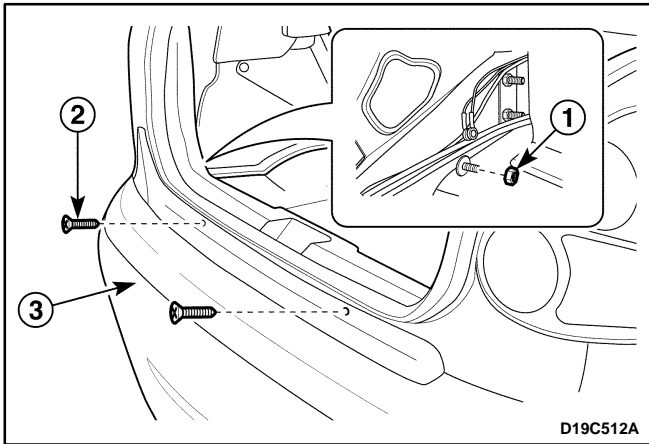

4. Lower the vehicle.

5. Remove the fascia.

- Remove the nuts in the luggage compartment (1).
- Remove the screws (2).
- Remove the fascia (3).

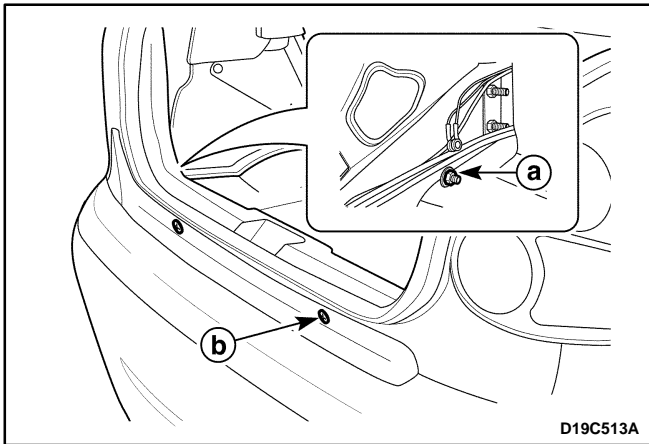

Installation Procedure

Notice: Dissimilar metals in direct contact with each other may corrode rapidly. Make sure to use the correct fasteners to prevent premature corrosion.

1. Install the fascia.
2. Install the fascia upper nut.
 - a. The fascia upper nut.
3. Install the fascia upper screws.
 - b. The fascia upper screws.

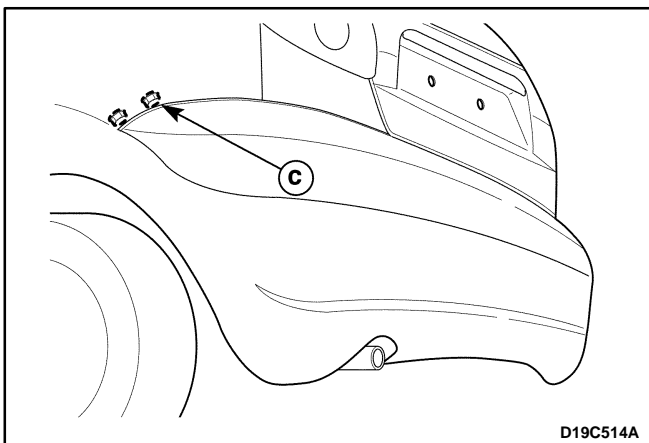

4. Raise and suitably support the vehicle.

5. Install the fascia lower bolts.

- c. The fascia lower bolts.

6. Lower the vehicle.

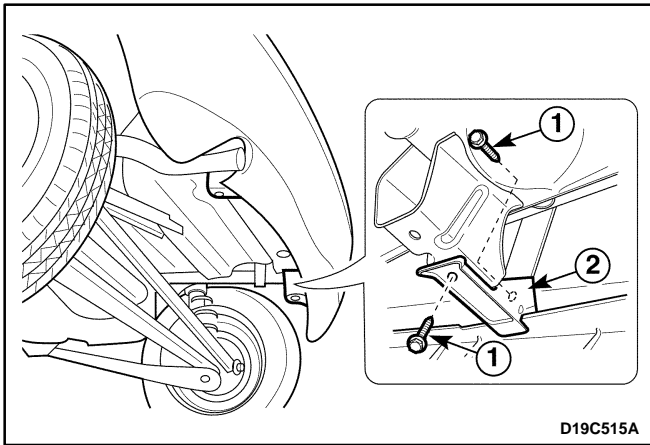

REAR BUMPER BRACKET

Removal Procedure

1. Raise and suitably support the vehicle.
2. Remove the rear bumper bracket.
 - Remove the bolts (1).
 - Remove the bracket (2).

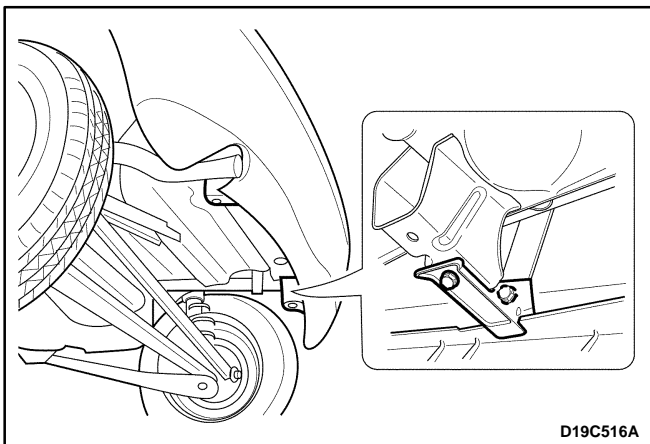

Installation Procedure

1. Install the rear bumper bracket with the bolts.
2. Lower the vehicle.