SECTION 9M

EXTERIOR TRIM

TABLE OF CONTENTS

Description and Operation	9M-2	Roof Molding	9M-3
Emblems and Lettering	9M-2	Rear Spoiler	9M-3
Mud Guards	9M-2	Front Bumper Spacer	9M-4
Repair Instructions	9M-3	Tailgate Handle	9M-5
On-Vehicle Service	9M-3		

DESCRIPTION AND OPERATION

EMBLEMS AND LETTERING

The emblems and lettering on the vehicle are attached by adhesive. The company emblem appears on the hood. The lettering, which appears in several places on the body of the vehicle, features the model, the grade, and the company name.

MUD GUARDS

Front and rear mud guards are optional equipment on all models. Mud guards will help prevent an excessive buildup of mud on the body.

REPAIR INSTRUCTIONS

ON-VEHICLE SERVICE

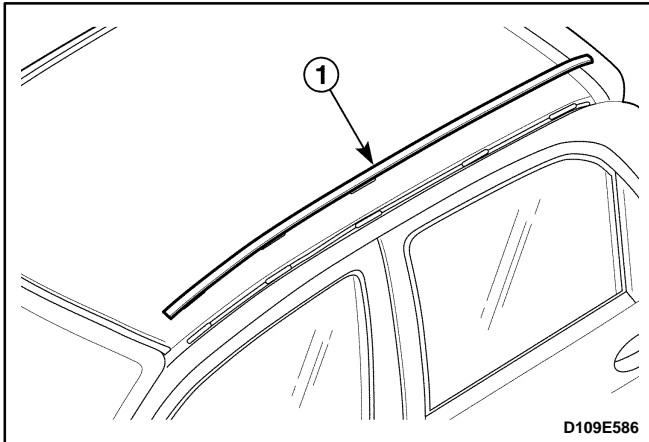

ROOF MOLDING

Removal Procedure

1. Remove the roof molding from the plastic clips (1).

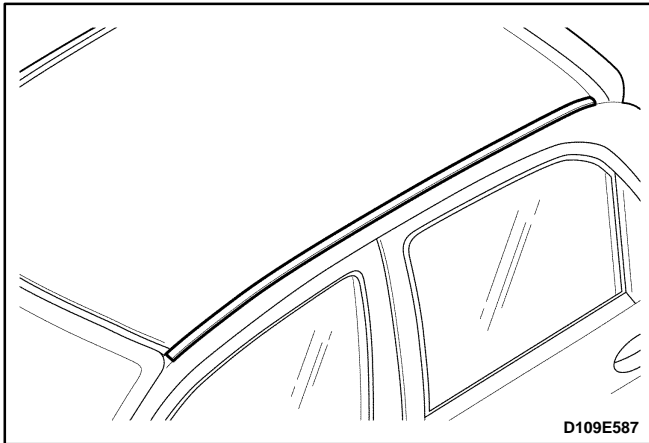

Installation Procedure

1. Press the roof molding onto the plastic clips.

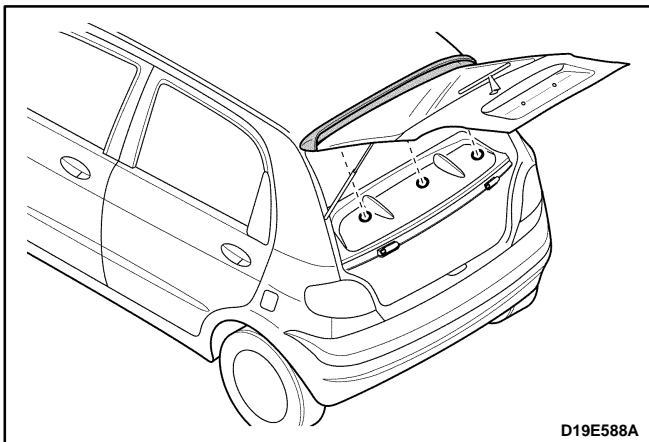

REAR SPOILER

Removal Procedure

1. Open the tailgate.
2. Remove the spoiler seals.

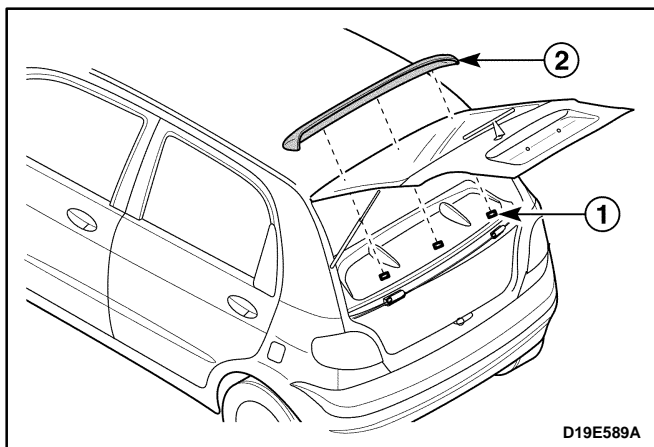

3. Remove the rear spoiler from the tailgate.
 - Remove the nuts (1).
 - Remove the rear spoiler (2).

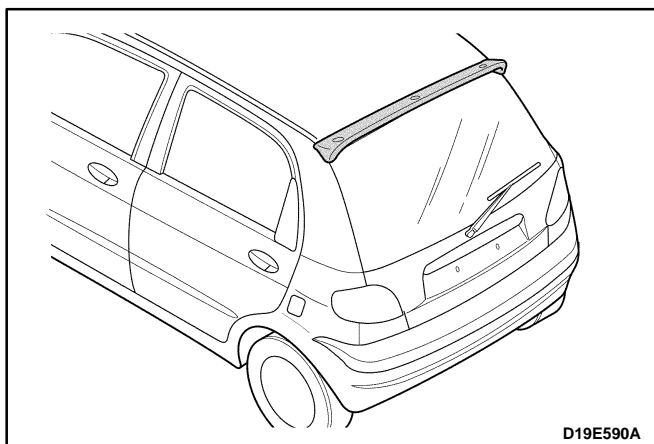

Installation Procedure

1. Install the rear spoiler on the tailgate with the nuts.
2. Install the spoiler seals.

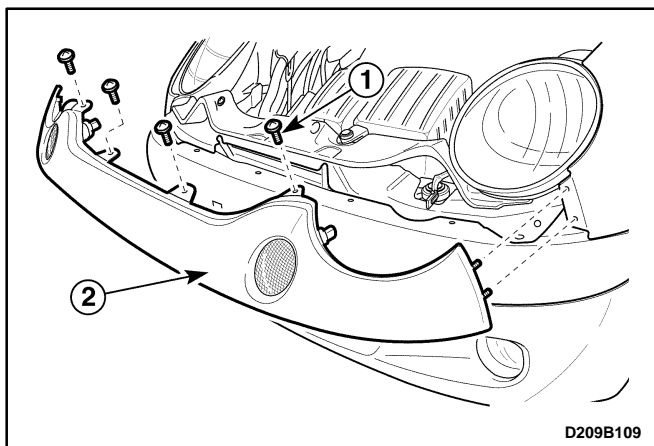

FRONT BUMPER SPACER

Removal Procedure

1. Support the hood suitably.
2. Disconnect the negative battery cable.
3. Remove the front bumper spacer.
 - Remove the bolts (1).
 - Remove the front bumper spacer from the bumper fascia (2).
4. Remove the turn signal lamps. Refer to *Section 9B, Lighting Systems*.

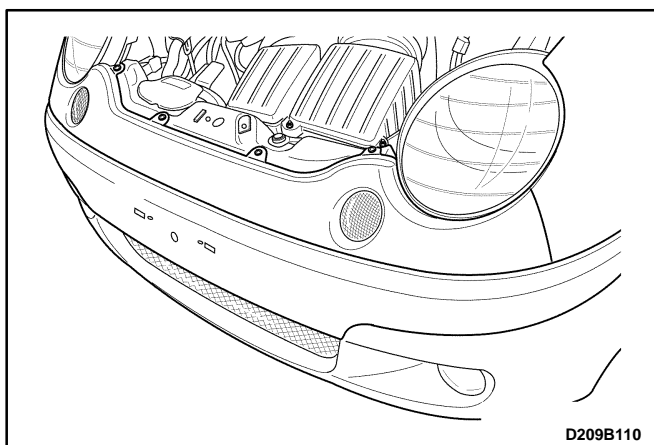

Installation Procedure

1. Install the turn signal lamps. Refer to *Section 9B, Lighting Systems*.
2. Install the front bumper spacer with the bolts.
3. Connect the negative battery cable.

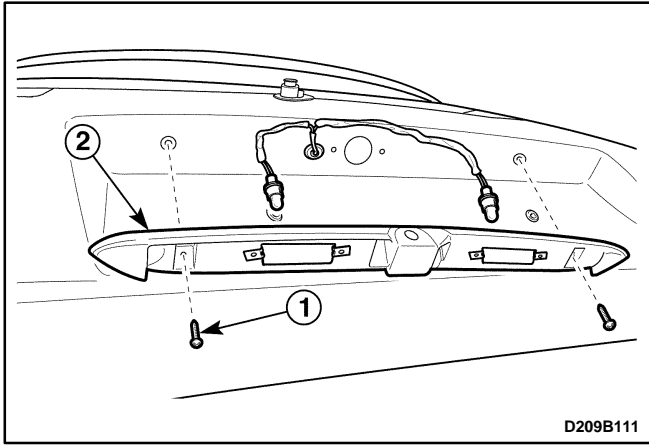

TAILGATE HANDLE

Removal Procedure

1. Disconnect the negative battery cable.
2. Open the tailgate.
3. Remove the tailgate lock cylinder. Refer to *Section 9P, Doors*.
4. Remove the license plate lamps. Refer to *Section 9B, Lighting Systems*.
5. Remove the tailgate handle.
 - Remove the screws (1).
 - Remove the tailgate handle (2).

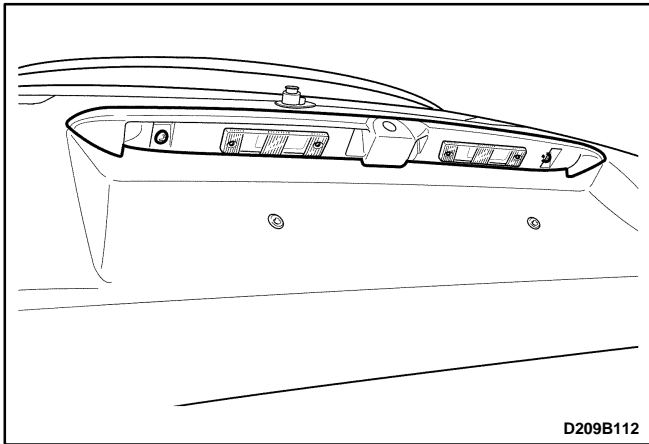

Installation Procedure

1. Install the tailgate handle with the screws.
2. Install the license plate lamps. Refer to *Section 9B, Lighting Systems*.
3. Remove the tailgate lock cylinder. Refer to *Section 9P, Doors*.
4. Connect the negative battery cable.