SECTION 9D

WIPERS/WASHER SYSTEMS

CAUTION: Disconnect the negative battery cable before removing or installing any electrical unit or when a tool or equipment could easily come in contact with exposed electrical terminals. Disconnecting this cable will help prevent personal injury and damage to the vehicle. The ignition must also be in B unless otherwise noted.

TABLE OF CONTENTS

Description and Operation	9D-2	Windshield Wiper Linkage	9D-9
Windshield Wiper System	9D-2	Windshield Wiper Blade	9D-10
Windshield Washer System	9D-2	Washer Reservoir	9D-10
Rear Window Wiper/Washer System	9D-2	Washer Pump	9D-11
Diagnostic Information and Procedures	9D-3	Windshield Washer Nozzle	9D-12
Windshield/Rear Window Wiper and Washer System	9D-3	Rear Window Washer Nozzle	9D-12
Repair Instructions	9D-6	Washer Hose	9D-13
On-Vehicle Service	9D-6	Specifications	9D-15
Windshield Wiper Arm	9D-6	Fastener Tightening Specifications	9D-15
Rear Window Wiper Arm	9D-6	Schematic and Routing Diagrams	9D-16
Windshield Wiper Motor	9D-7	Windshield/Rear Window Wiper/Washer System	9D-16
Rear Window Wiper Motor	9D-8		

DESCRIPTION AND OPERATION

WINDSHIELD WIPER SYSTEM

The windshield wiper system consists of a wiper motor, a linkage, a wiper arm and a blade, and a wiper/washer switch. The windshield wiper circuit incorporates a self-parking device which consists of a worm gear and a cam plate in order to keep the circuit engage temporarily when the switch is turned off. The wiper system is driven by a permanent magnet-type motor. The windshield wiper motor is mounted on the dash panel and is directly connected to the windshield wiper linkage.

The windshield wiper motor has two speeds, LOW and HIGH, and also has intermittent wiper capability. The wiper switch is an integral part of the wiper/washer switch. Windshield wiper operation is actuated through the lever on the right side of the steering column.

WINDSHIELD WASHER SYSTEM

The windshield washer system is equipped with a washer fluid reservoir, a washer fluid pump, hoses, nozzles,

and a wiper/washer switch. The windshield washer reservoir is mounted inner the front right wheel well splash shield. Attached to the reservoir is a washer pump, which pumps fluid through the hoses to the two nozzles mounted on the cowl panel. The washer switch is an integral part of the wiper/washer switch. Windshield washer operation is actuated through the lever on the right side of the steering column.

REAR WIPER/WASHER SYSTEM

The rear wiper/washer system is equipped with the high grade vehicle. The rear wiper and the washer are one assembly. The rear washer is installed to the rear wiper. The rear wiper/washer switch is same with the windshield wiper. Push the switch to one position forward and the rear wiper operate slowly. And push more the switch forward and the rear wiper/washer system operate.

DIAGNOSTIC INFORMATION AND PROCEDURES

WINDSHIELD/REAR WINDOW WIPER AND WASHER SYSTEM

Condition	Probable Cause	Correction
Windshield Wipers Do Not Work At Any Speed	<ul style="list-style-type: none"> The open or a short in the power supply circuit to the fuse F8. 	<ul style="list-style-type: none"> Repair or replace the open a short in the power supply circuit to the fuse F8.
	<ul style="list-style-type: none"> Fuse F8 is blown. 	<ul style="list-style-type: none"> Replace the fuse F8.
	<ul style="list-style-type: none"> Faulty wiper/washer switch. 	<ul style="list-style-type: none"> Replace the wiper/washer switch.
	<ul style="list-style-type: none"> The circuit between the wiper/washer switch connector and the wiper relay is open or short. 	<ul style="list-style-type: none"> Repair or Replace the wiring harness.
	<ul style="list-style-type: none"> The circuit between the fuse F8 and the wiper relay is open or short. 	<ul style="list-style-type: none"> Repair or Replace the wiring harness.
	<ul style="list-style-type: none"> Faulty wiper relay. 	<ul style="list-style-type: none"> Replace the wiper relay.
	<ul style="list-style-type: none"> The circuit between the wiper relay and the ground G201 is the open circuit or a short circuit. 	<ul style="list-style-type: none"> Repair or Replace the open circuit or a short circuit between the wiper relay and the ground G201.
	<ul style="list-style-type: none"> The circuit between the wiper/washer switch and the wiper motor is the open circuit or a short circuit. 	<ul style="list-style-type: none"> Repair or Replace the wiring harness.
	<ul style="list-style-type: none"> The circuit between the fuse F8 and the wiper motor is the open circuit or a short circuit. 	<ul style="list-style-type: none"> Repair or Replace the wiring harness.
	<ul style="list-style-type: none"> The circuit between the wiper relay and the wiper motor is the open circuit or a short circuit. 	<ul style="list-style-type: none"> Repair or Replace the wiring harness.
	<ul style="list-style-type: none"> Faulty wiper motor. 	<ul style="list-style-type: none"> Replace the wiper motor.
	<ul style="list-style-type: none"> The connection of the wiper linkage and the wiper motor is poor. 	<ul style="list-style-type: none"> Tighten completely the nut. Tighten completely the ball.
	<ul style="list-style-type: none"> Wiper linkage is out of order. 	<ul style="list-style-type: none"> Replace the wiper linkage.
Wipers Do Not Work On High Speed, Low Speed OK	<ul style="list-style-type: none"> Faulty wiper/washer switch. 	<ul style="list-style-type: none"> Replace the wiper/washer switch.
	<ul style="list-style-type: none"> The circuit between the wiper/washer switch and the wiper motor is the open circuit or a short circuit. 	<ul style="list-style-type: none"> Repair or Replace the wiring harness.
	<ul style="list-style-type: none"> Faulty wiper motor. 	<ul style="list-style-type: none"> Replace the wiper motor.
Wipers Do Not Work On Low Speed, High Speed OK	<ul style="list-style-type: none"> Faulty wiper/washer switch. 	<ul style="list-style-type: none"> Replace the wiper/washer switch.
	<ul style="list-style-type: none"> The circuit between the wiper/washer switch and the wiper motor is the open circuit or a short circuit. 	<ul style="list-style-type: none"> Repair or Replace the wiring harness.
	<ul style="list-style-type: none"> Faulty wiper motor. 	<ul style="list-style-type: none"> Replace the wiper motor.

WINDSHIELD/REAR WINDOW WIPER AND WASHER SYSTEM(Cont'd)

Condition	Probable Cause	Correction
Wipers Do Not On Intermittent, Other Speed OK	<ul style="list-style-type: none"> ● The circuit between the fuse F8 and the wiper relay is the open circuit or a short circuit. 	<ul style="list-style-type: none"> ● Repair or Replace the wiring harness.
	<ul style="list-style-type: none"> ● The circuit between the fuse F8 and the wiper motor is the open circuit or a short circuit. 	<ul style="list-style-type: none"> ● Repair or Replace the wiring harness.
	<ul style="list-style-type: none"> ● Faulty wiper/washer switch. 	<ul style="list-style-type: none"> ● Replace the wiper/washer switch.
	<ul style="list-style-type: none"> ● The circuit between the wiper/washer switch and the wiper relay is the open circuit or a short circuit. 	<ul style="list-style-type: none"> ● Repair or Replace the wiring harness.
	<ul style="list-style-type: none"> ● Faulty wiper relay. 	<ul style="list-style-type: none"> ● Replace the wiper relay.
	<ul style="list-style-type: none"> ● The circuit between the wiper relay and the wiper motor is the open circuit or a short circuit. 	<ul style="list-style-type: none"> ● Repair or Replace the wiring harness.
	<ul style="list-style-type: none"> ● Poor ground G201. 	<ul style="list-style-type: none"> ● Repair or Replace the wiring harness.
	<ul style="list-style-type: none"> ● Faulty wiper motor. 	<ul style="list-style-type: none"> ● Replace the wiper motor.
Windshield Washer Does Not Work, Windshield Wipers OK	<ul style="list-style-type: none"> ● The open or a short in the power supply circuit to the fuse F9. 	<ul style="list-style-type: none"> ● Repair or Replace the open or a short in the power supply circuit to the fuse F9.
	<ul style="list-style-type: none"> ● Fuse F9 is blown. 	<ul style="list-style-type: none"> ● Replace the fuse.
	<ul style="list-style-type: none"> ● The circuit between the fuse F9 and the wiper/washer switch is the open circuit or a short circuit. 	<ul style="list-style-type: none"> ● Repair or Replace the wiring harness.
	<ul style="list-style-type: none"> ● Faulty wiper/washer switch. 	<ul style="list-style-type: none"> ● Replace the wiper/washer switch.
	<ul style="list-style-type: none"> ● The circuit between the wiper/washer switch and the wiper relay is the open circuit or a short circuit. 	<ul style="list-style-type: none"> ● Repair or Replace the wiring harness.
	<ul style="list-style-type: none"> ● Faulty wiper relay. 	<ul style="list-style-type: none"> ● Replace the wiper relay.
	<ul style="list-style-type: none"> ● The circuit between the wiper relay and ground G201 is the open circuit or a short circuit. 	<ul style="list-style-type: none"> ● Repair or Replace the wiring harness.
	<ul style="list-style-type: none"> ● The circuit between the wiper/washer switch and the windshield washer pump is the open circuit or a short circuit. 	<ul style="list-style-type: none"> ● Repair or Replace the wiring harness.
	<ul style="list-style-type: none"> ● Faulty windshield washer pump. 	<ul style="list-style-type: none"> ● Replace the windshield wash pump.
	<ul style="list-style-type: none"> ● Poor ground G201. 	<ul style="list-style-type: none"> ● Repair or Replace the wiring harness.

WINDSHIELD/REAR WINDOW WIPER AND WASHER SYSTEM(Cont'd)

Condition	Probable Cause	Correction
Rear Wiper Does Not Work	<ul style="list-style-type: none"> • The open or a short in the power supply circuit to the fuse F9. 	<ul style="list-style-type: none"> • Repair or Replace the open or a short in the power supply circuit to the fuse F8.
	<ul style="list-style-type: none"> • Fuse F9 is blown. 	<ul style="list-style-type: none"> • Replace the fuse F9.
	<ul style="list-style-type: none"> • The circuit between the fuse F9 and the wiper/washer switch is the open circuit or a short circuit. 	<ul style="list-style-type: none"> • Repair or Replace the wiring harness.
	<ul style="list-style-type: none"> • Faulty wiper/washer switch. 	<ul style="list-style-type: none"> • Replace the wiper/washer switch.
	<ul style="list-style-type: none"> • The circuit between the wiper/washer switch and the rear window wiper motor is the open circuit or a short circuit. 	<ul style="list-style-type: none"> • Repair or Replace the wiring harness.
	<ul style="list-style-type: none"> • The circuit between the fuse F9 and the rear window wiper motor is the open circuit or a short circuit. 	<ul style="list-style-type: none"> • Repair or Replace the wiring harness.
	<ul style="list-style-type: none"> • Faulty rear window wiper motor. 	<ul style="list-style-type: none"> • Replace the rear window wiper motor.
	<ul style="list-style-type: none"> • Poor ground G403. 	<ul style="list-style-type: none"> • Repair or Replace the wiring harness.
Rear Window Washer Does Not Work, Rear Window Wiper OK	<ul style="list-style-type: none"> • The open or a short in the power supply circuit to the fuse F9. 	<ul style="list-style-type: none"> • Repair or Replace the open or a short in the power supply circuit to the fuse F9.
	<ul style="list-style-type: none"> • Fuse F9 is blown. 	<ul style="list-style-type: none"> • Replace the fuse F9.
	<ul style="list-style-type: none"> • The circuit between the fuse F9 and wiper/washer switch is the open circuit or a short circuit. 	<ul style="list-style-type: none"> • Repair or Replace the wiring harness.
	<ul style="list-style-type: none"> • Faulty wiper/washer switch. 	<ul style="list-style-type: none"> • Replace the wiper/washer switch.
	<ul style="list-style-type: none"> • The circuit between the wiper/washer switch and the windshield washer pump is the open circuit or a short circuit. 	<ul style="list-style-type: none"> • Repair or replace the wiring harness.
	<ul style="list-style-type: none"> • Faulty windshield washer pump. 	<ul style="list-style-type: none"> • Replace the windshield washer pump.
	<ul style="list-style-type: none"> • Poor ground G102. 	<ul style="list-style-type: none"> • Repair or Replace the wiring harness.

REPAIR INSTRUCTIONS

ON-VEHICLE SERVICE

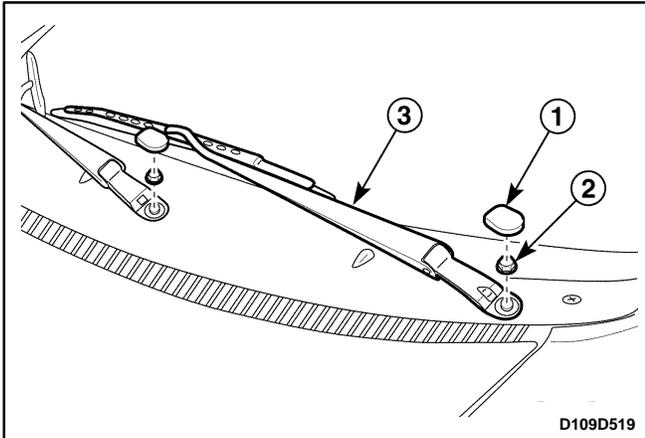

WINDSHIELD WIPER ARM

(Left-Hand Drive Shown, Right-Hand Drive Similar)

Removal Procedure

1. Remove the wiper arm.
 - Remove the cap (1).
 - Remove the nut (2).
 - Remove the wiper arm (3).

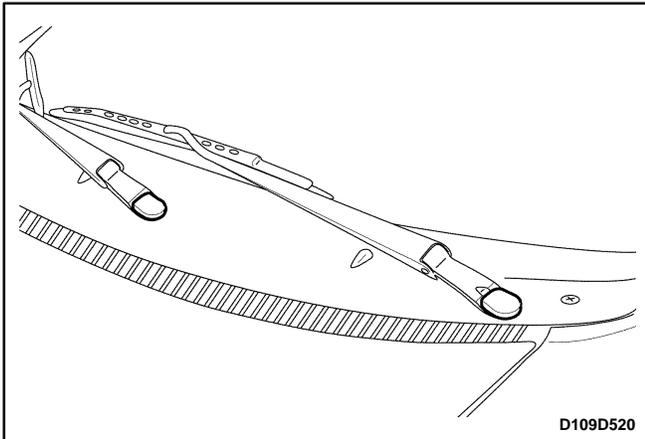

Installation Procedure

1. Install the wiper arm with the nut.
2. Install the cap.

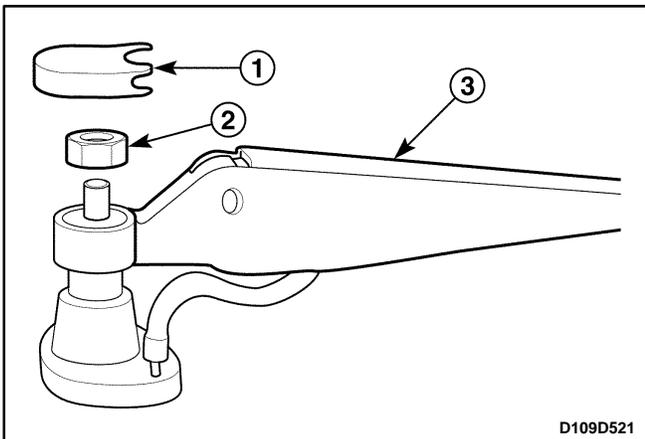

REAR WINDOW WIPER ARM

Removal Procedure

1. Remove the washer nozzle from the wiper arm. Refer to "Rear Washer Nozzle" in this section.
2. Remove the wiper blade. Refer to "Windshield Wiper Blade" in this section.
3. Remove the wiper arm.
 - Remove the cap (1).
 - Remove the nut (2).
 - Remove the wiper arm (3).

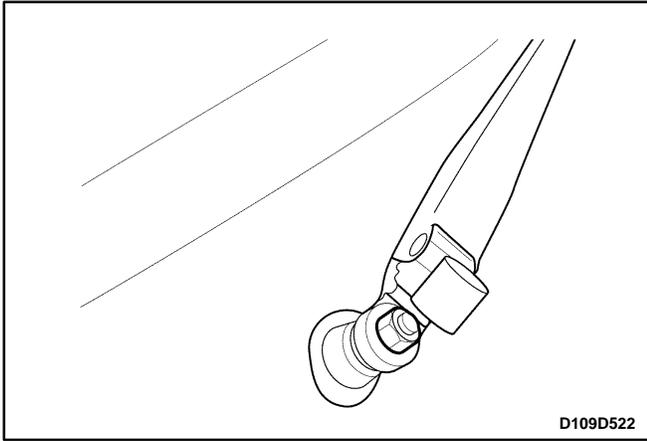

Installation Procedure

1. Install the rear wiper arm with the nut.
2. Install the cap.
3. Install the wiper blade. Refer to "Windshield Wiper Blade" in this section.
4. Install the washer nozzle to the wiper arm. Refer to "Rear Washer Nozzle" in this section.

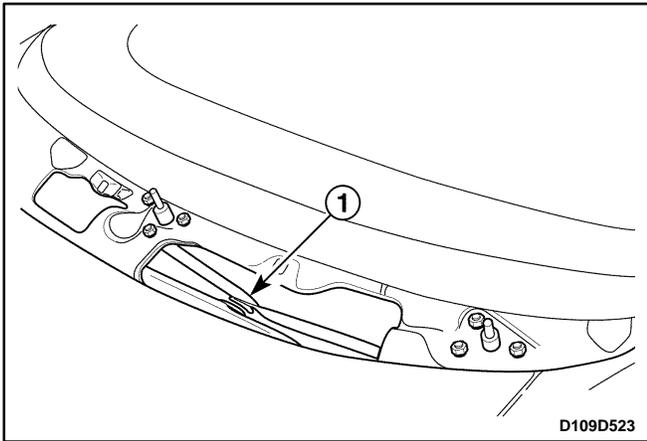

WINDSHIELD WIPER MOTOR

(Left-Hand Drive Shown, Right-Hand Drive Similar)

Removal Procedure

1. Disconnect the negative battery cable.
2. Remove the windshield wiper arm. Refer to "Windshield Wiper Arm" in this section.
3. Remove the cowl vent grille. Refer to *Section 9R, Body Front End*.
4. Separate the wiper motor from the wiper linkage.
 - Remove the wiper linkage ball from the wiper linkage (1).
5. Remove the wiper motor from the engine room.
 - Disconnect the electrical connector (1).
 - Remove the bolts (2).
 - Remove the wiper motor assembly (3).

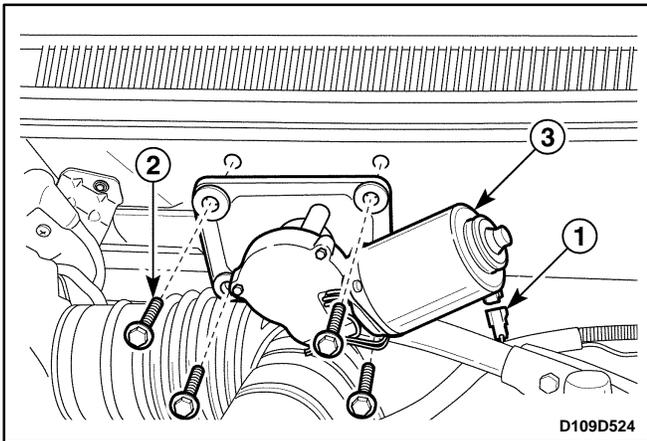

Caution: Because the wiper motor link plate is fixed, do not separate the wiper motor from the bracket.

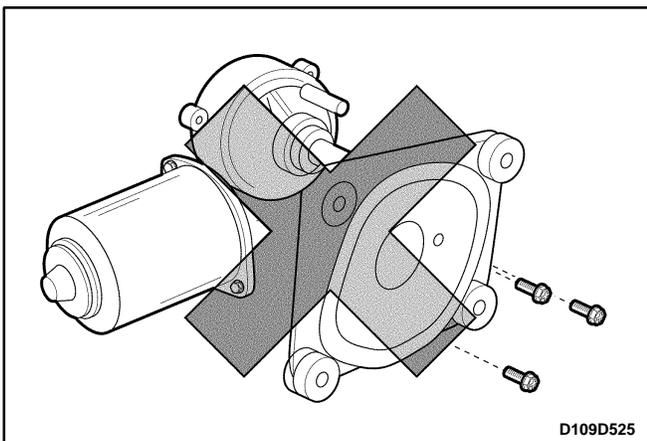

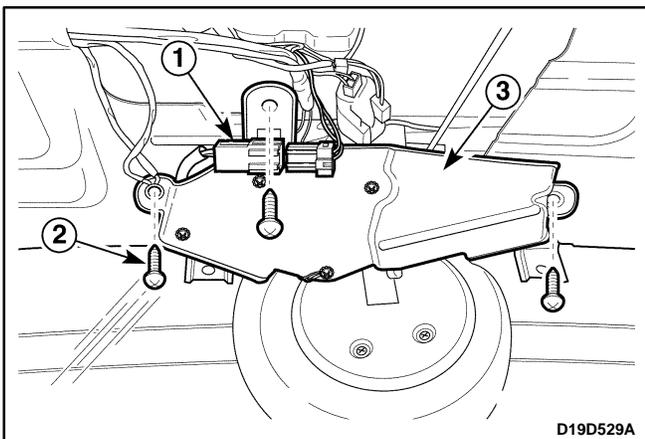
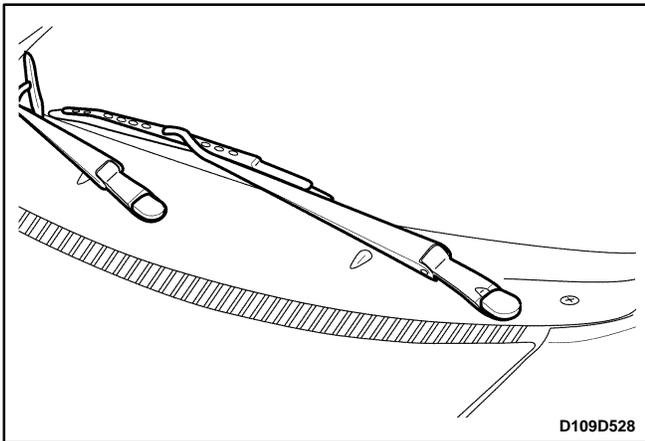
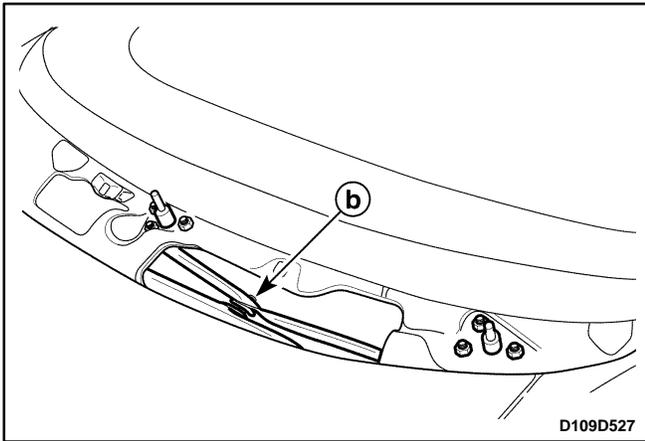
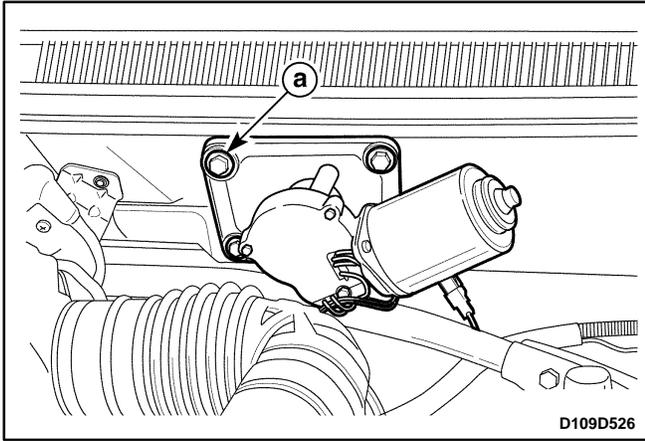

Installation Procedure

1. Install the wiper motor to the engine room with the bolts.
 - a. Wiper motor assembly bolt.
2. Connect the electrical connector.
3. Install the wiper linkage to the wiper motor linkage ball.
 - b. Wiper linkage ball.
4. Install the cowl vent grille. Refer to *Section 9R, Body Front End*.
5. Install the windshield wiper arm. Refer to "Windshield Wiper Arm" in this section.
6. Connect the negative battery cable.

REAR WINDOW WIPER MOTOR

Removal Procedure

1. Disconnect the negative battery cable.
2. Remove the wiper arm from the tailgate. Refer to "Windshield Wiper Arm" in this section.
3. Remove the tailgate inside trim. Refer to *Section 9G, Interior Trim*.
4. Remove the rear wiper motor assembly.
 - Disconnect the electrical connector (1).
 - Remove the screws (2).
 - Remove the rear wiper motor assembly (3).

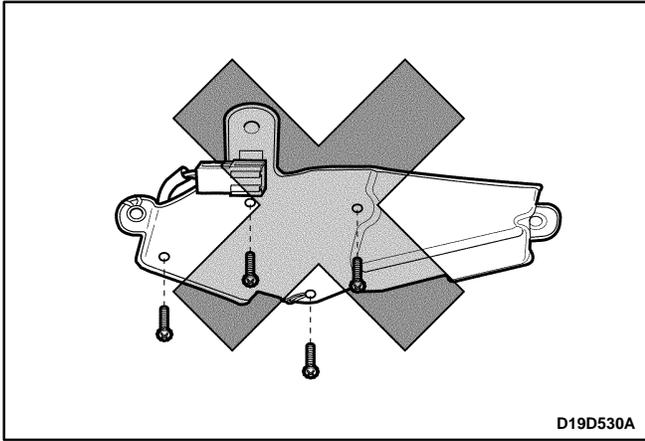

Caution: Because the wiper motor link plate is fixed, do not separate the wiper motor from the bracket.

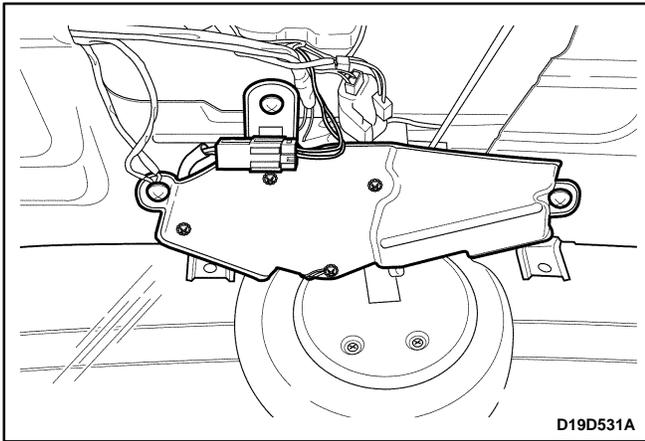

Installation Procedure

1. Install the wiper motor assembly to the tailgate with the screws.
2. Connect the electrical connector.
3. Install the tailgate inside trim. Refer to *Section 9G, Interior Trim*.
4. Install the wiper arm. Refer to "Windshield Wiper Arm" in this section.
5. Connect the negative battery cable.

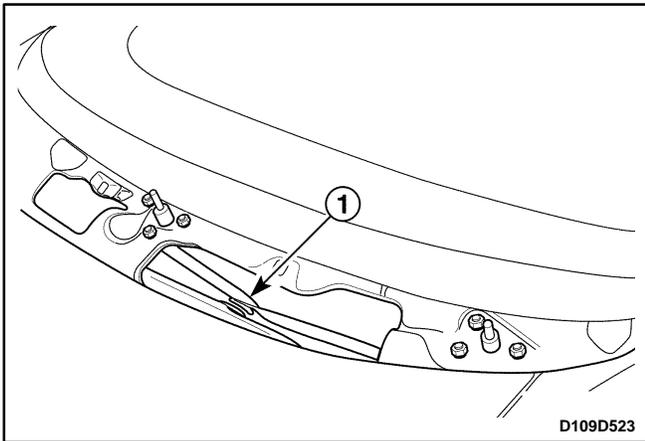

WINDSHIELD WIPER LINKAGE

(Left-Hand Drive Shown, Right-Hand Drive Similar)

Removal Procedure

1. Remove the windshield wiper arms. Refer to "Windshield Wiper Arm" in this section.
2. Remove the cowl vent grille. Refer to *Section 9R, Body Front End*.
3. Separate the wiper linkage from the wiper motor.
 - Separate the wiper linkage from the wiper motor linkage ball (1).
4. Remove the wiper linkage.
 - Remove the wiper linkage nuts (1).
 - Remove the wiper linkage (2).

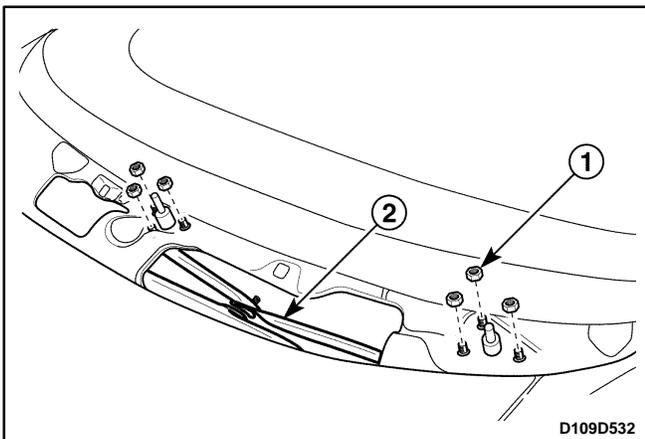

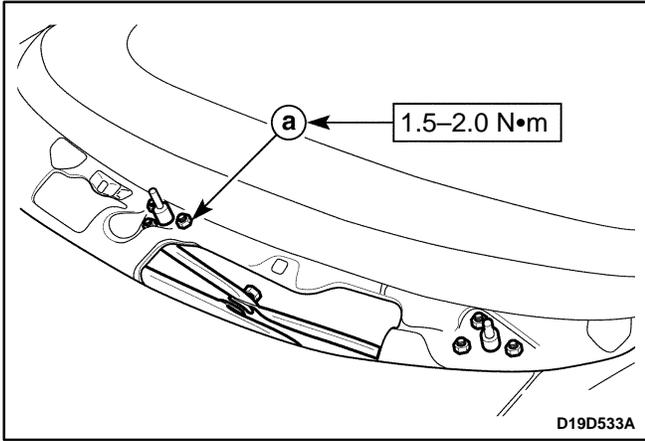

Installation Procedure

1. Install the wiper linkage with the wiper linkage nuts.

Tighten

Tighten the wiper linkage nuts to 1.5–2.0 N•m (13–18 lb-in).

- a. Wiper linkage nut.
2. Install the wiper motor linkage ball.
 3. Install the cowl vent grille. Refer to *Section 9R, Body Front End*.
 4. Install the windshield wiper arms. Refer to "Windshield Wiper Arm" in this section.

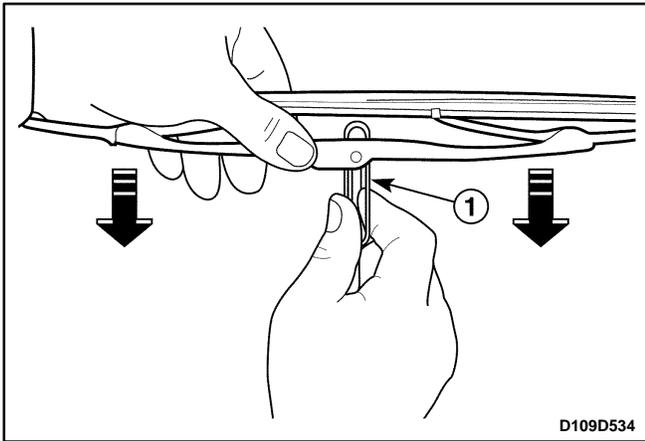

WINDSHIELD WIPER BLADE

Removal Procedure

1. Pull the wiper blade off the arm by pushing the wiper blade retaining clip (1).

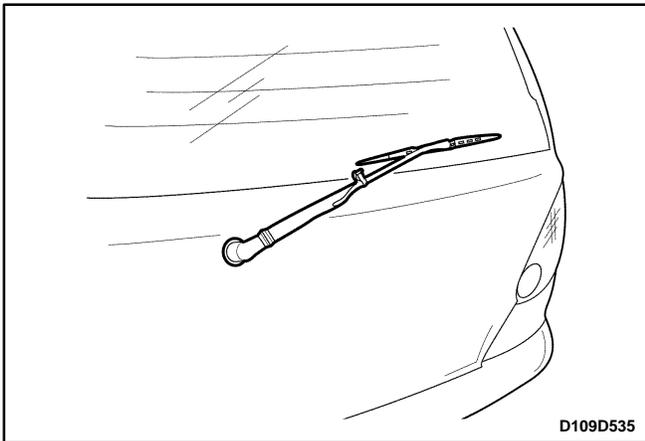

Installation Procedure

1. Install the wiper blade to the arm.

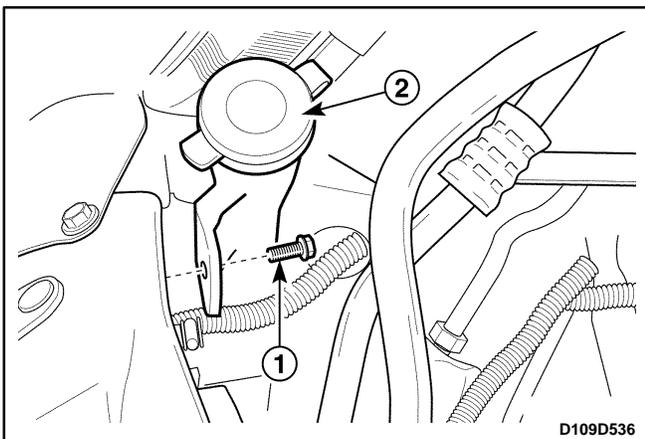

WASHER RESERVOIR

Removal Procedure

1. Disconnect the negative battery cable.
2. Remove the washer reservoir inlet.
 - Remove the bolt (1).
 - Remove the washer reservoir inlet (2).

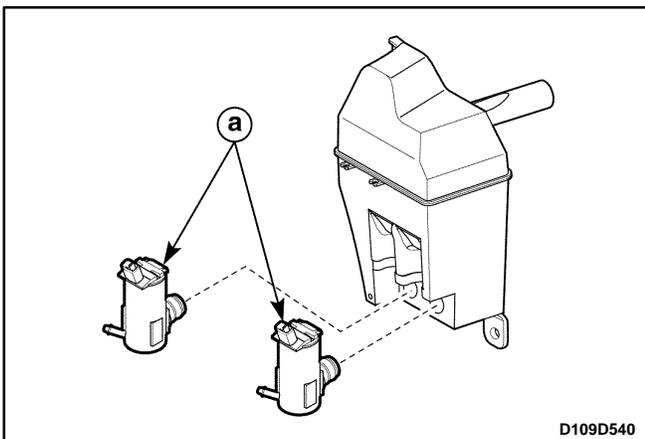
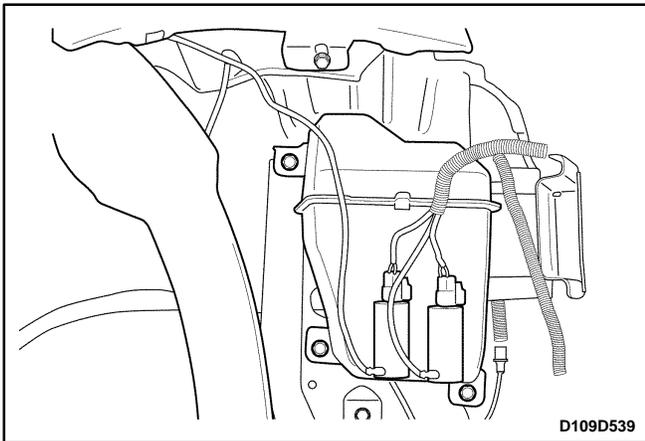
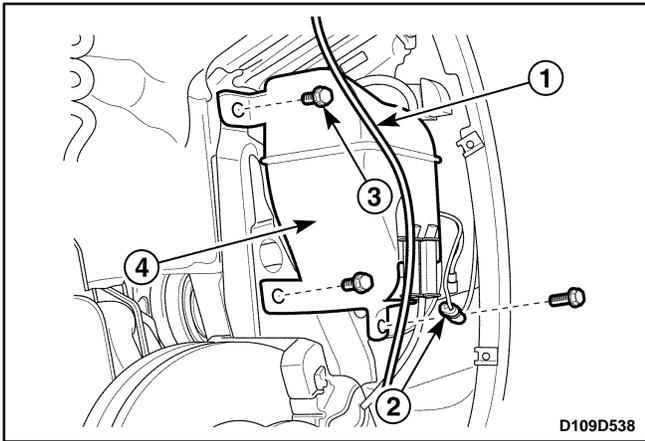
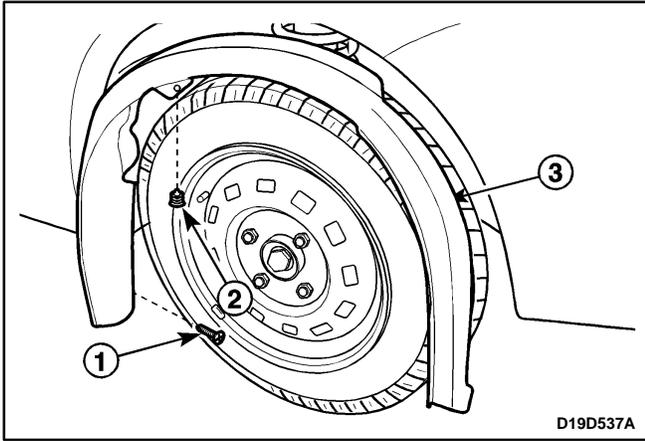

3. Raise and suitably support the vehicle.
4. Remove the front RH wheelhouse splash shield.
 - Remove the screws (1).
 - Remove the clips (2).
 - Remove the wheelhouse splash shield (3).

5. Remove the washer reservoir assembly.
 - Drain the washer fluid.
 - Disconnect the washer hose connector (1).
 - Disconnect the washer pump electrical connector (2).
 - Remove the bolts (3).
 - Remove the washer reservoir assembly (4).

Installation Procedure

1. Install the washer reservoir assembly with the bolts.
2. Connect the washer pump electrical connector.
3. Connect the washer hose connector.
4. Install the front RH wheelhouse splash shield with the screws and the clips.
5. Lower the vehicle.
6. Install the washer reservoir with the bolt.
7. Connect the negative battery cable.

WASHER PUMP

Removal Procedure

1. Disconnect the negative battery cable.
2. Remove the washer reservoir assembly. Refer to "Washer Reservoir" in this section.
3. Drain the washer fluid.
4. Remove the wiper motor from the washer reservoir assembly.
 - a. Washer pump.

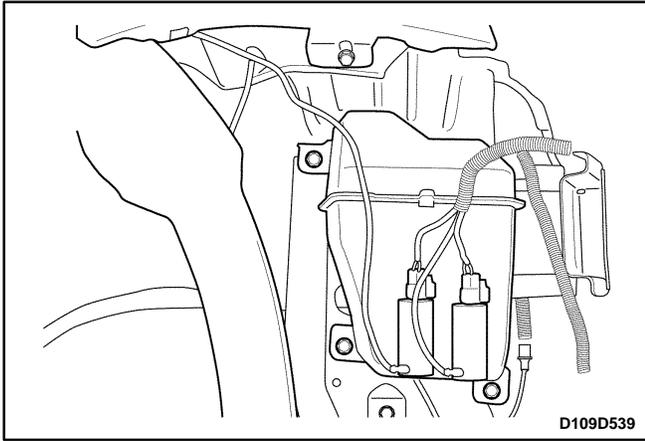

Installation Procedure

1. Install the wiper motor to the washer reservoir assembly.
2. Install the washer reservoir assembly. Refer to "Washer Reservoir" in this section.
3. Connect the negative battery cable.
4. Fill the washer reservoir.

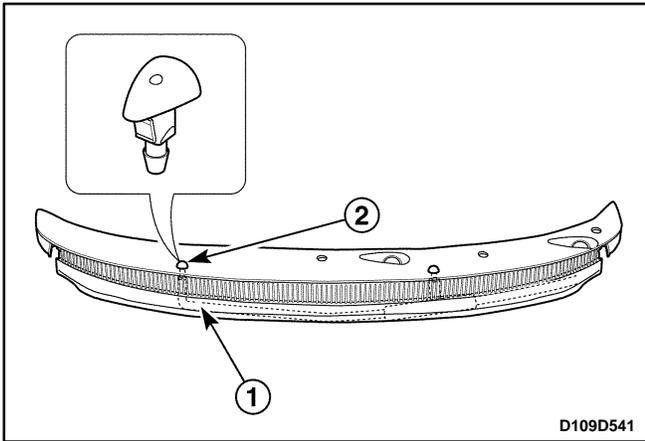

WINDSHIELD WASHER NOZZLE

Removal Procedure

1. Remove the cowl vent grille. Refer to *Section 9R, Body Front End*.
2. Remove the washer nozzle from the cowl vent grille.
 - Disconnect the washer nozzle hose (1).
 - Remove the washer nozzle (2).

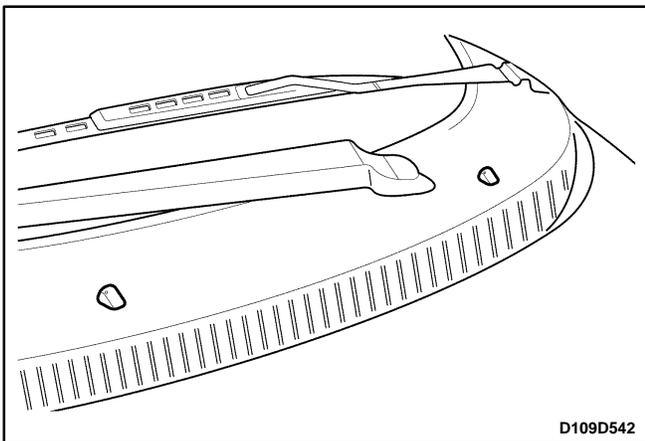

Installation Procedure

1. Install the washer nozzle to the cowl vent grille.
2. Install the washer nozzle hose to the washer nozzle.
3. Install the cowl vent grille. Refer to *Section 9R, Body Front End*.

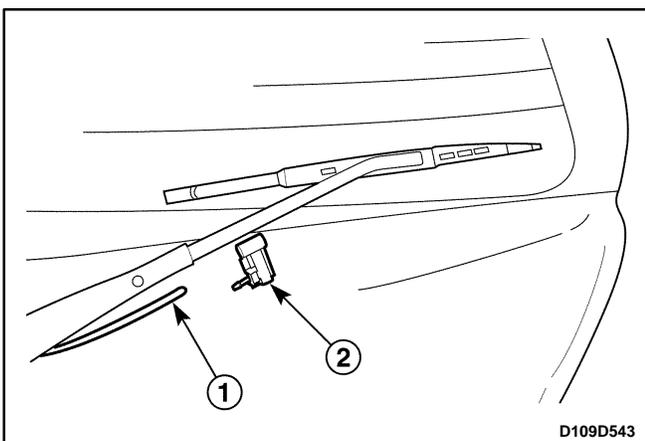

REAR WINDOW WASHER NOZZLE

Removal Procedure

1. Remove the washer nozzle from the wiper arm.
 - Disconnect the washer nozzle hose (1).
 - Remove the washer nozzle (2).

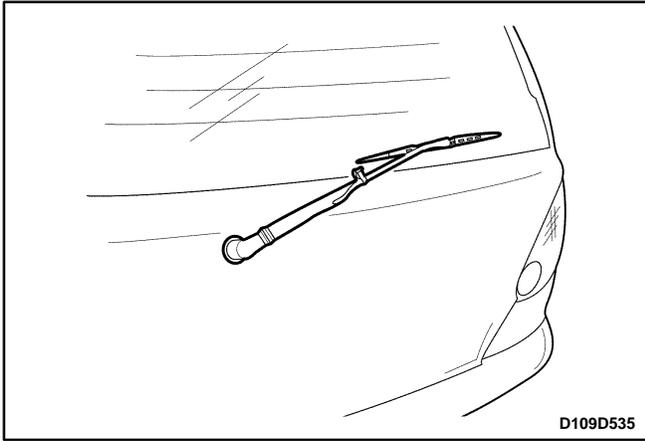

Installation Procedure

1. Install the washer nozzle to the wiper arm assembly.
 - Install the washer nozzle hose in the wiper arm return spring.
 - Fix the washer nozzle into the wiper arm.
 - Install the washer nozzle hose to the pivot cap connector.

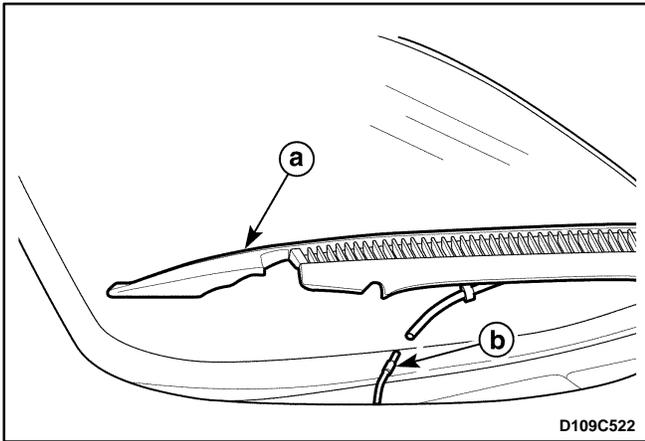

WASHER HOSE

Removal Procedure

1. Remove the cowl vent grille. Refer to *Section 9R, Body Front End*.
 - a. Cowl vent grille.
2. Disconnect the washer hose connector.
 - b. Washer hose connector.

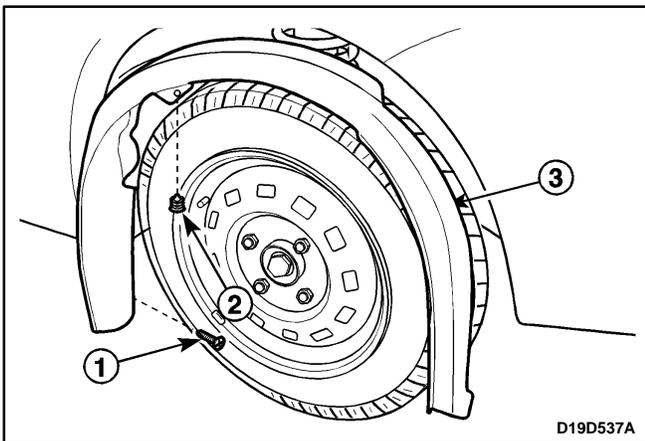

3. Raise and suitably support the vehicle.
4. Remove the front RH wheel.
5. Remove the front RH wheel house splash shield.
 - Remove the screws (1).
 - Remove the clips (2).
 - Remove the wheel house splash shield (3).

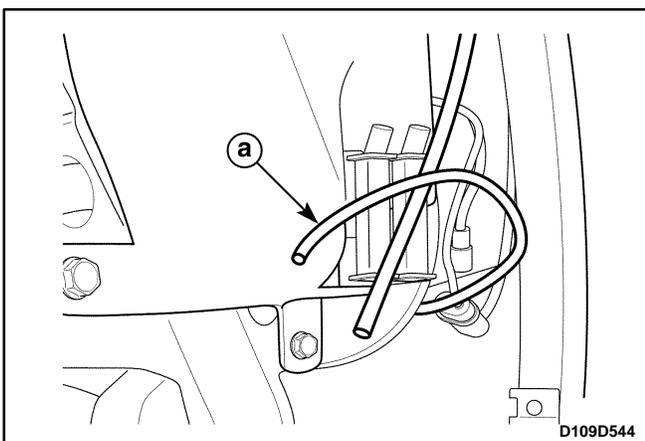

6. Disconnect the washer hose from the washer pump.
 - a. Washer hose.

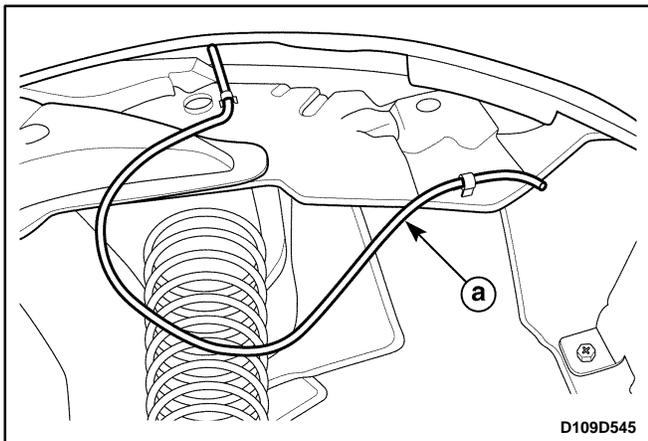

7. Remove the washer hose.

a. Washer hose.

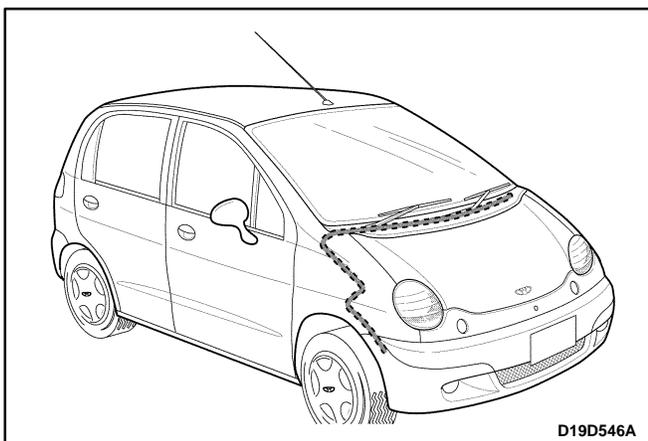

Installation Procedure

1. Connect the washer hose to the washer pump.
2. Install the front RH wheel house splash shield with the screws and the clips.
3. Install the front RH wheel.
4. Lower the vehicle.
5. Connect the washer hose connector.
6. Install the cowl vent grille. Refer to *Section 9R, Body Front End*.

SPECIFICATIONS

FASTENER TIGHTENING SPECIFICATIONS

Application	N•m	Lb-Ft	Lb-In
Wiper Linkage Conclusion Nut	1.5-2.0	-	13-18

SCHEMATIC AND ROUTING DIAGRAMS

WINDSHIELD/REAR WINDOW WIPER AND WASHER SYSTEM

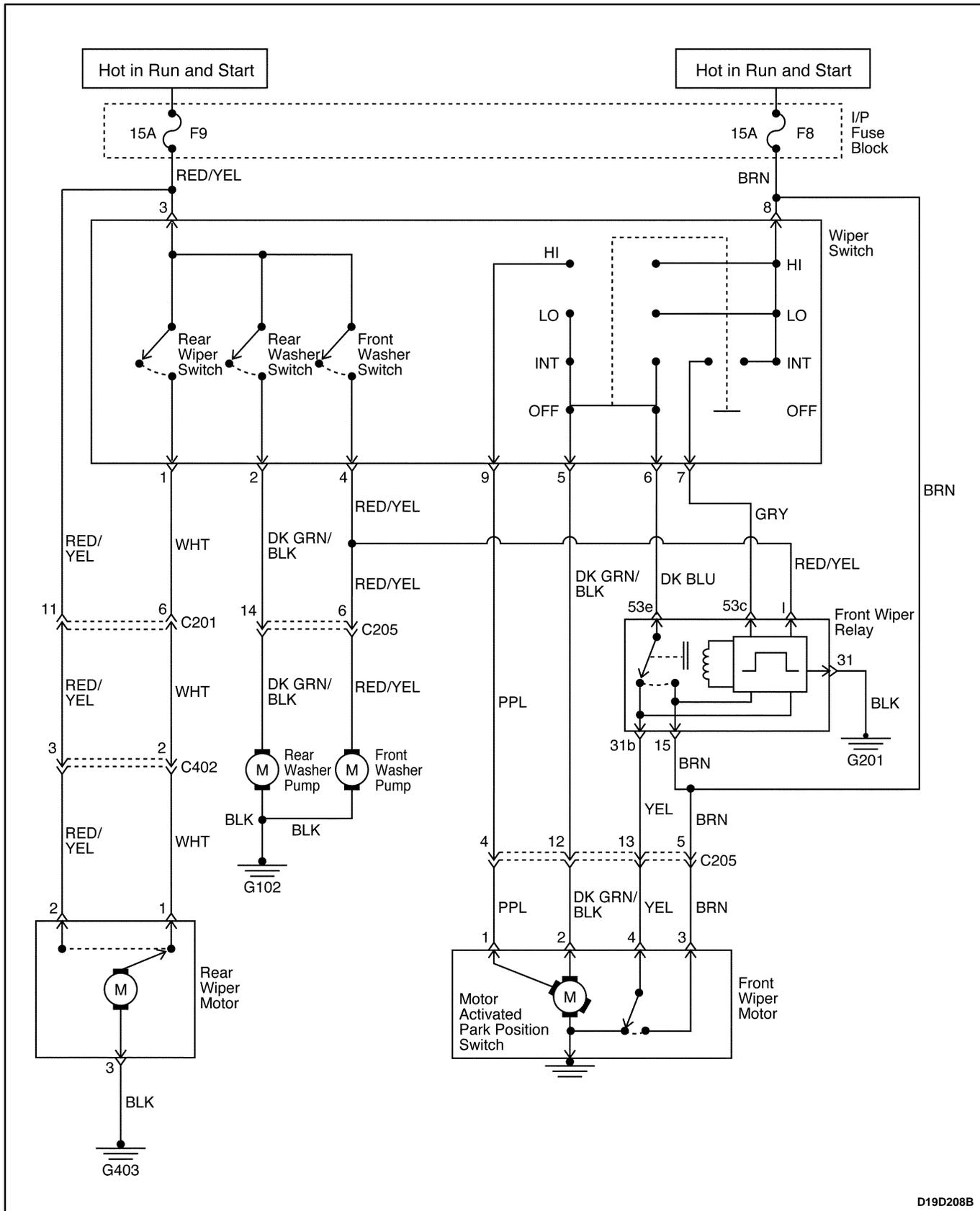

D19D208B