SECTION 6D

MANUAL STEERING GEAR

CAUTION: *Disconnect the negative battery cable before removing or installing any electrical unit or when a tool or equipment could easily come in contact with exposed electrical terminals. Disconnecting this cable will help prevent personal injury and damage to the vehicle. The ignition must also be in B unless otherwise noted.*

TABLE OF CONTENTS

Description and Operation	6D-2	On-Vehicle Service	6D-7
Manual Rack and Pinion	6D-2	Tie Rod End	6D-7
Component Locator	6D-3	Rack and Pinion Boot	6D-8
Manual Rack and Pinion Steering Gear	6D-3	Rack and Pinion Steering Gear Assembly	6D-9
Diagnostic Information and Procedures	6D-4	Unit Repair	6D-11
Manual Rack and Pinion Steering Gear	6D-4	Tie Rod End Boot	6D-11
Straight-Ahead Check	6D-5	Rack and Pinion	6D-11
Steering Wheel Restoration	6D-6	Specifications	6D-17
Check The Turning Resistance of the Tie Rod End or Tie Rod	6D-6	General Specifications	6D-17
Adjust the Free Load of the Steering Gear	6D-6	Fastener Tightening Specifications	6D-17
Repair Instructions	6D-7	Special Tools and Equipment	6D-18
		Special Tools Table	6D-18

DESCRIPTION AND OPERATION

MANUAL RACK AND PINION

The manual rack and pinion steering system consists of two main components: the rack and the pinion. The motion of the pinion is transferred through the pinion teeth that mesh with the teeth on the rack, which moves the rack. The force is then transmitted through the arms on the struts, which turn the wheels.

COMPONENT LOCATOR

MANUAL RACK AND PINION STEERING GEAR

(Left-Hand Drive Shown, Right-Hand Drive Similar)

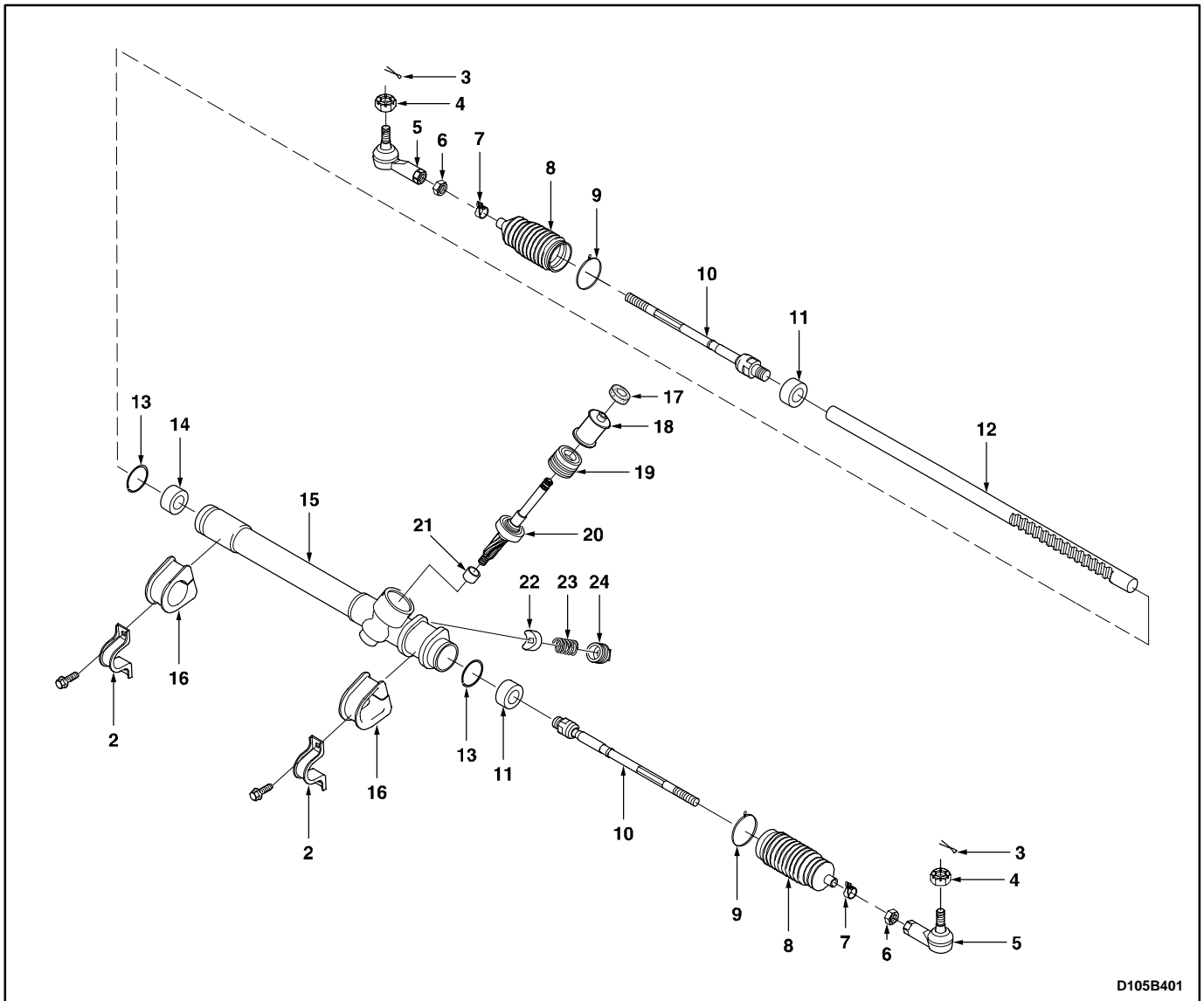

D105B401

- | | |
|------------------------------------|-----------------------------------|
| 1. Manual Steering Gear | 13. Bulkhead Retainer |
| 2. Steering Gear Bracket | 14. Bulkhead Bushing |
| 3. Cotter Pin | 15. Steering Gear Housing |
| 4. Castellated Nut | 16. Steering Gear Bracket Bushing |
| 5. Tie Rod End | 17. Packing |
| 6. Tie Rod End Lock Nut | 18. Dust Cover |
| 7. Rack and Pinion Boot Clamp | 19. Pinion Plug |
| 8. Rack and Pinion Boot | 20. Steering Pinion Gear |
| 9. Rack and Pinion Boot Wire Clamp | 21. Roller Bearing |
| 10. Tie Rod | 22. Rack Bearing |
| 11. Shock Damper Ring | 23. Adjuster Spring |
| 12. Steering Rack Gear | 24. Adjuster Plug |

DIAGNOSTIC INFORMATION AND PROCEDURES**MANUAL RACK AND PINION STEERING GEAR**

Condition	Probable Cause	Correction
Excessive Play or Looseness in the Steering System	● Poor adjustment of steering gear.	● Perform straight-ahead check.
	● Improperly installed tie rods.	● Tighten the tie rods.
Rattling Noise in the Steering Gear	● Improper and insufficient lubrication.	● Lubricate the rack and pinion assembly.
	● Improperly installed steering gear mounting.	● Tighten the steering gear mounting bolts.
	● Improperly installed tie rods.	● Tighten the tie rods.

STRAIGHT-AHEAD CHECK

After all the necessary operations on the steering gear are completed, check the exact straight-ahead position of the steering in each case.

With the vehicle on the floor, place the steering wheel in the straight-ahead position. Mark the centerline of both tires on the floor. Turn the steering wheel all the way to the right and mark the new centerline of both tires on the floor.

Application	Tire	Specified Valve
Inside Angle	145, 155	37.5 – 41.5°
	175	32.9 – 36.9°
Outside Angle	145, 155	31.5 – 35.5°
	175	28.5 – 32.5°

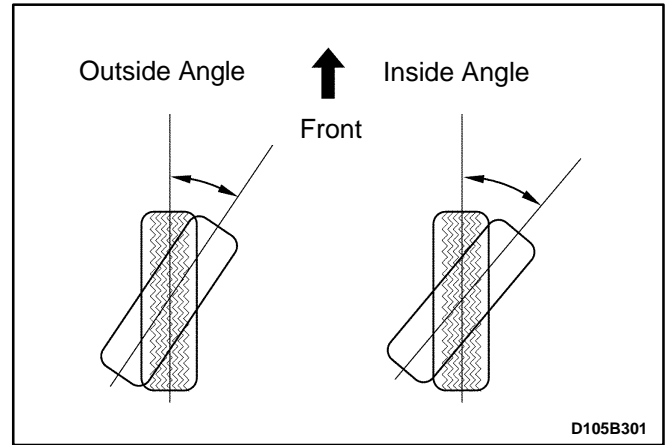

Straight Ahead Check Table

Step	Action	Value(s)	Yes	No
1	Place the steering wheel in the straight-ahead position. Is the wheel in the correct position?	–	Go to Step 2	–
2	Is the steering wheel off center by more than 5 degrees?	–	Go to Step 4	Go to Step 5
3	The pinion is displaced on the rack. The steering pinion position must be corrected. Is the repair complete?	–	Go to Step 2	–
4	Remove steering wheel and center on the spindle splines. Is the repair complete?	–	Go to Step 2	–
5	Turn the steering wheel all the way to the right. Measure the inner and the outer angles of the tire centerline compared to the straight-ahead centerline. Do the angles match the value specified?	Refer to “Straight-Ahead Check” in this section	System OK	Go to Step 6
6	The rack assembly was not assembled correctly. Repair as needed. Is the repair complete?	–	Go to Step 5	–

STEERING WHEEL RESTORATION

1. Turn the steering wheel fast to the right and left and turn it slowly as the same way.
2. Check if the steering wheel restoration for the wheel turning to right and the one to the left are same.
3. Turn the steering wheel to 90° about 1–2 seconds and loosen the steering wheel during the low speed driving.
4. If the steering wheel restores above 70%, the steering wheel restoration is OK.
5. If the restoration is poor, check the tire pressure, steering gear preload, and steering gear operation. And repair the fault.

CHECK THE TURNING RESISTANCE OF THE TIE ROD END OR TIE ROD

1. Turn the ball joint of the tie rod end or the tie rod about 10 times.
2. Use a spring balance to check the turning resistance of each ball joint.

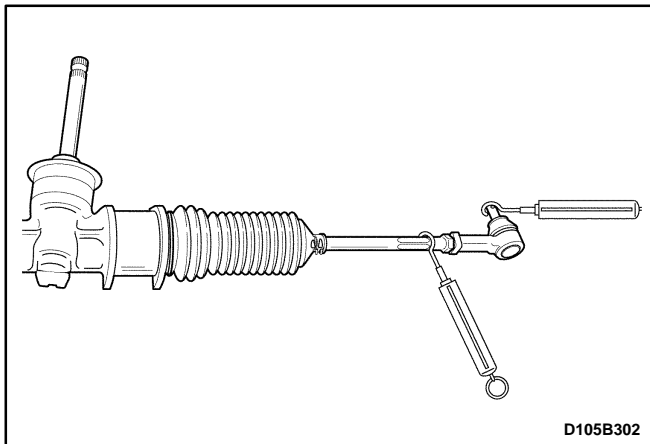

Application	Specified Value
Tie Rod End Ball Joint	0.49 – 3.43 N•m (4.5 – 30 lb-in.)
Tie Rod Ball Joint	0.49 – 3.43 N•m (4.5 – 30 lb-in.)

3. If the values exceed the specified values, replace the tie rod end or the tie rod.
4. But, If the ball joint of the tie rod end or the tie rod falls down of itself, replace it.

ADJUST THE FREE LOAD OF THE STEERING GEAR

1. Place the steering wheel in the straight-ahead position.
2. Raise and suitably support the vehicle.
3. Check the torque of the adjuster plug.
4. When the measured torque is below the specification value or the measured torque is over the specification value, adjust the tightening torque.
 - Place the rack gear in the straight-ahead position.
 - Tighten the adjust plug to 95 N•m (70 lb-ft).
 - Turn the steering wheel all the way to the right and the left about 5 times repeatedly.
 - Place the rack gear in the straight-ahead position.
 - Loosen the adjust plug.
 - Tighten the adjust plug to 8 N•m (71 lb-in.).
 - Set the torque in the 0.8–1.3 N•m (8–12 lb-in.) by loosening the adjust plug to 0° – 90°.

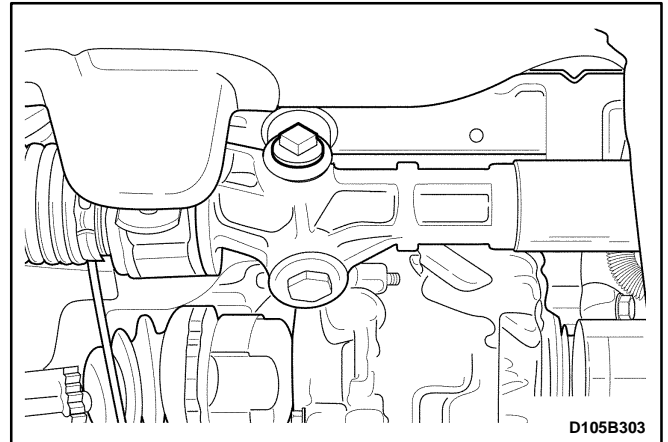

REPAIR INSTRUCTIONS

ON-VEHICLE SERVICE

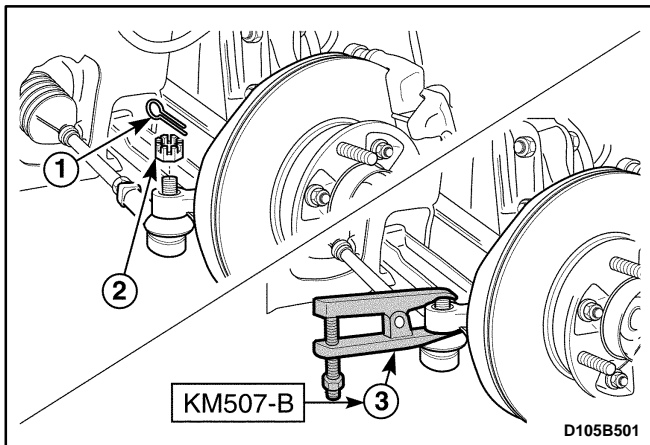

TIE ROD END

Tools Required

KM-507-B Ball Joint Remover

Removal Procedure

1. Remove the wheel. Refer to *Section 2E, Tires and wheels*.
2. Disconnect the tie rod and from the steering knuckle.
 - Remove the cotter pin (1).
 - Remove the castellated nut (2).
 - Use a ball joint remover KM-507-B, separate the tie rod end (3).
3. Remove the tie rod end.
 - Mark the tie rod, tie rod end lock nut and tie rod end (1).
 - Loosen the tie rod end lock nut anticlockwise (2).
 - Loosen the tie rod end (3).

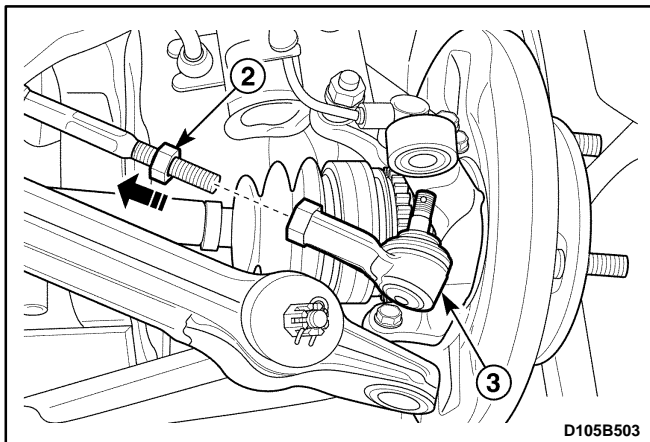
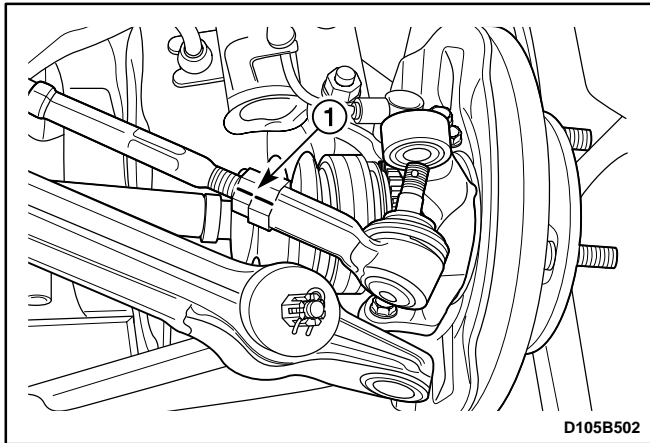

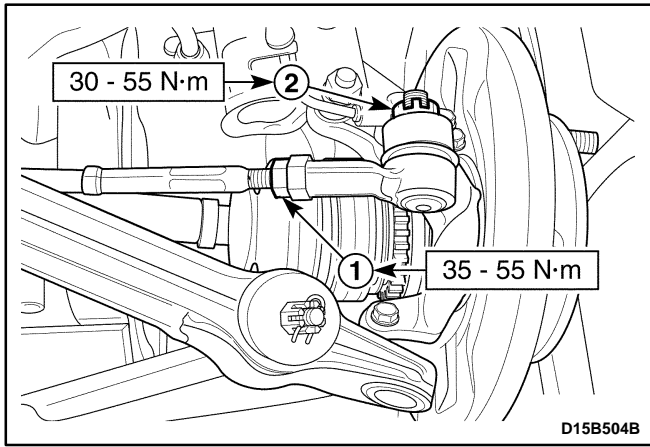

Installation Procedure

1. Install the tie rod end.
2. Install the tie rod lock nut (1).

Tighten

Tighten the tie rod end lock nut to 35–55 N•m (25–41 lb-ft).

3. Connect the tie rod end to the knuckle.
4. Install the tie rod end castellated nut (2).

Tighten

Tighten the castellated nut to 30–55 N•m (21–41 lb-ft).

5. Install the split pin.
6. Install the wheel. Refer to *Section 2E, Tires and Wheels*.
7. Make the toe-in adjustment by turning the tie rod adjuster. Refer to *Section 2B, Wheel Alignment*.

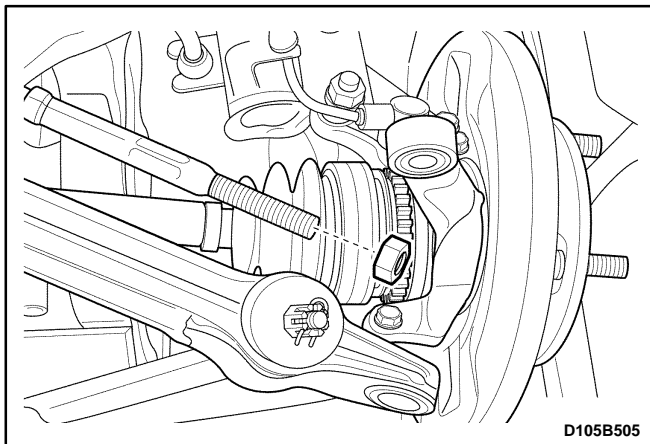

RACK AND PINION BOOT

Removal Procedure

1. Remove the tie rod end. Refer to “Tie Rod End” in this section.
2. Remove the tie rod end lock nut.

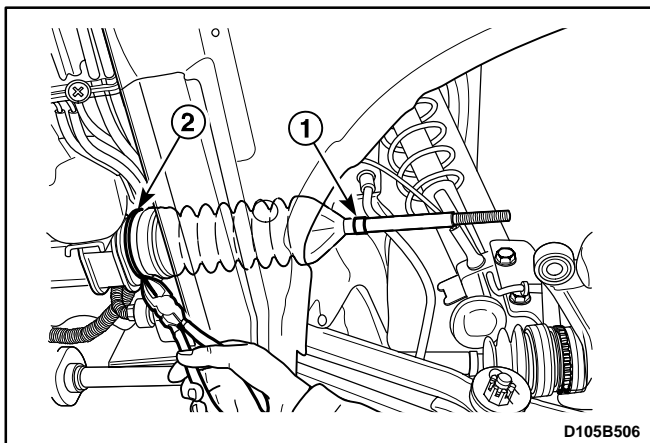

3. Remove the rack and pinion boot.
 - Remove the boot clamp (1).
 - Cut off the boot wire clamp (2).

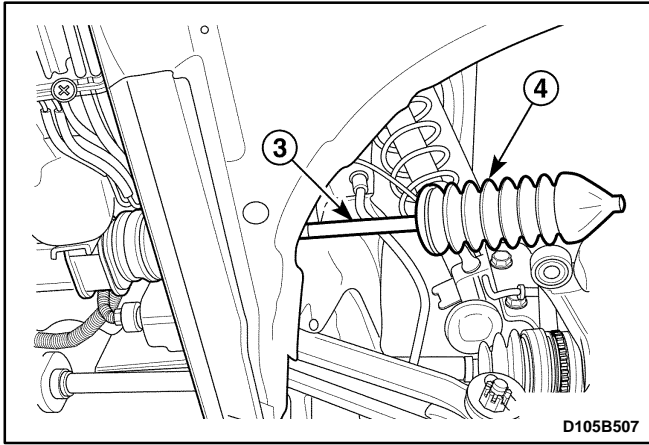

- Coat the greases on the tie rod to ease removal (3).
- Remove the boot (4).

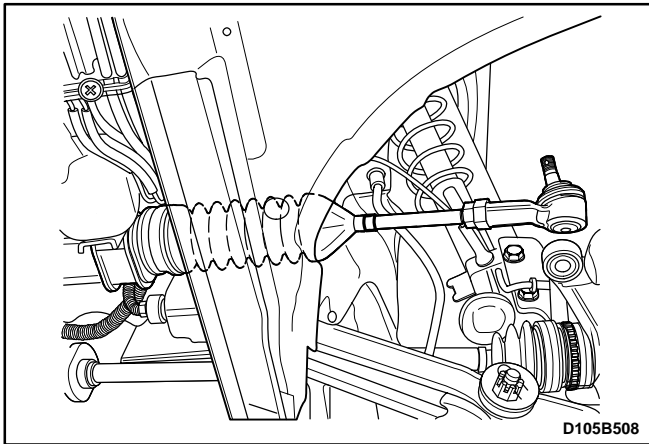

Installation Procedure

1. Install the rack and pinion boot with the clamp and the wire clamp.
2. Install the tie rod end nut.
3. Install the tie rod end. Refer to "Tie Rod End" in this section.

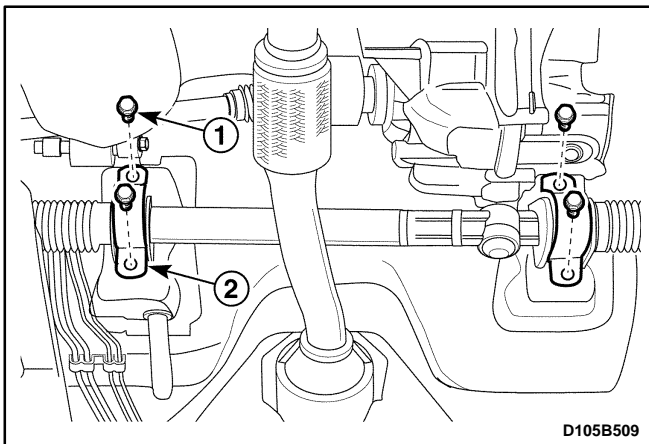

RACK AND PINION STEERING GEAR ASSEMBLY

(Left-Hand Drive Shown, Right-Hand Drive Similar)

Removal Procedure

1. Remove the intermediate shaft lower pinch bolt. Refer to *Section 6E, Steering Wheel and Column*.
2. Remove the wheels. Refer to *Section 2E, Tires and Wheels*.
3. Disconnect the tie rod end from the steering knuckle. Refer to "Tie Rod End" in this section.
4. Remove the front exhaust pipe nuts. Refer to *Section 1G, Engine Exhaust*.
5. Remove the steering gear assembly from the vehicle.
 - Remove the steering gear bracket bolts (1).
 - Remove the steering gear bracket (2).
 - Remove the steering gear assembly.
 - Remove the packing (3).

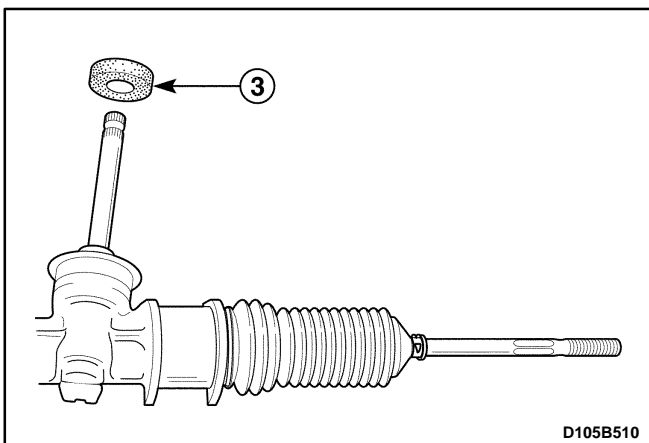

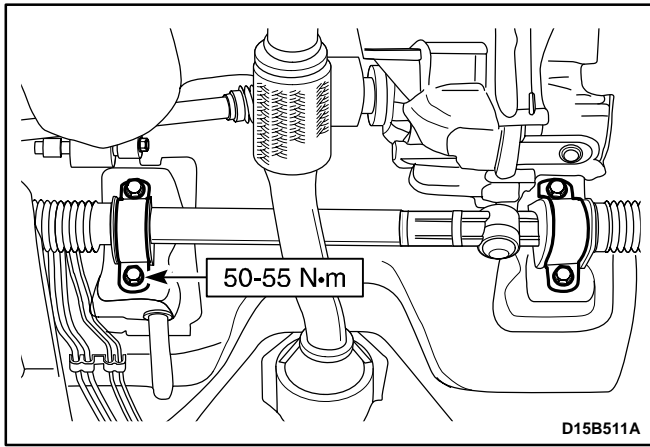

Installation Procedure

1. Install the mounting to the steering gear assembly.
2. Install the steering gear assembly.
3. Install the steering gear bracket with the bolts.

Tighten

Tighten the steering gear bracket bolts to 50–55 N•m (36–41 lb-ft).

4. Install the front exhaust pipe nuts. Refer to *Section 1G, Engine Exhaust*.
5. Connect the tie rod end to the steering knuckle. Refer to "Tie Rod End" in this section.
6. Install the wheels. Refer to *Section 2E, Tires and Wheels*.
7. Install the intermediate shaft lower pinch bolt. Refer to *Section 6E, Steering Wheel and Column*.

UNIT REPAIR

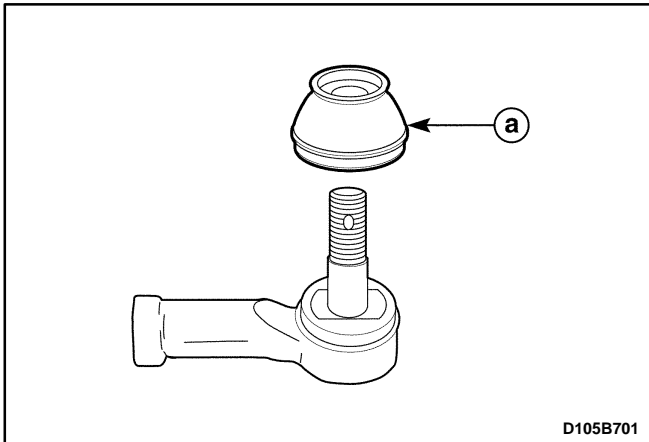

TIE ROD END BOOT

Disassembly Procedure

1. Remove the tie rod end. Refer to "Tie Rod End" in this section.
2. Remove the tie rod end boot.
 - a. Tie rod end boot.

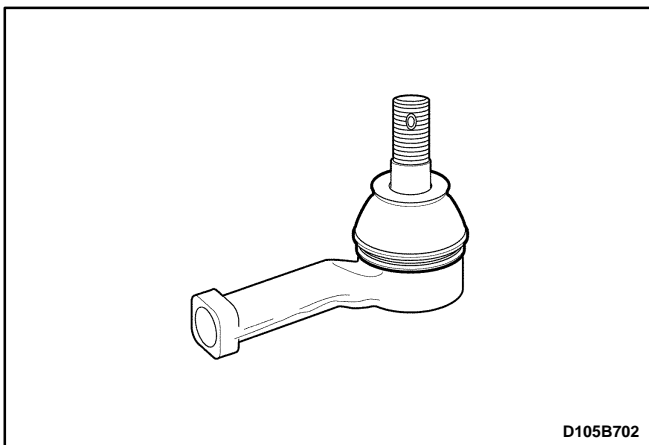

Assembly procedure

Important : Coat the grease inside of the boot.

1. Install the boot to the tie rod end.
2. Install the tie rod end wire clamp.
3. Install the tie rod end. Refer to "Tie Rod End" in this section.

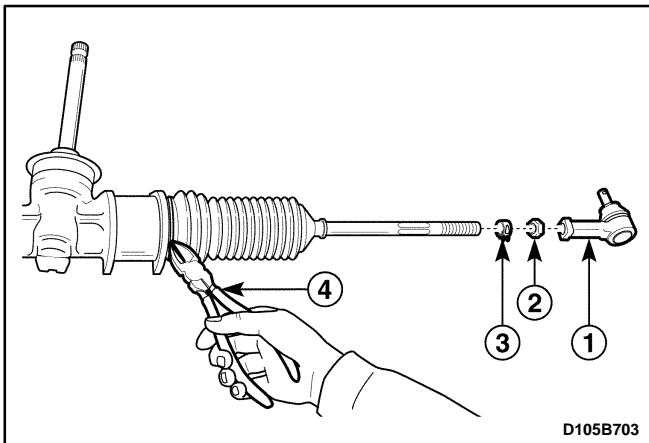

RACK AND PINION

(Left-Hand Drive Shown, Right-Hand Drive Similar)

Disassembly Procedure

1. Remove the rack and pinion steering assembly from the vehicle. Refer to "Rock and Pinion Assembly" in this section.
2. Remove the rack and pinion boot.
 - Remove the tie rod end. Refer to "Tie Rod End" in this section (1).
 - Remove the tie rod lock nut (2).
 - Remove the rack and pinion boot clamp (3).
 - Cut off the rack and pinion boot wire (4).

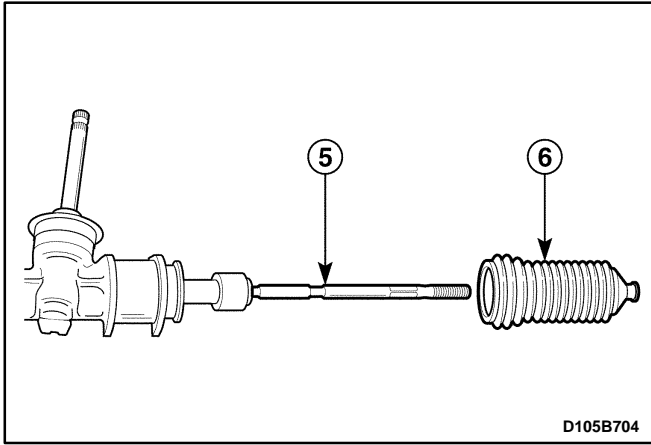

- Coat the greases on the tie rod (5).
- Remove the rack and pinion boot (6).

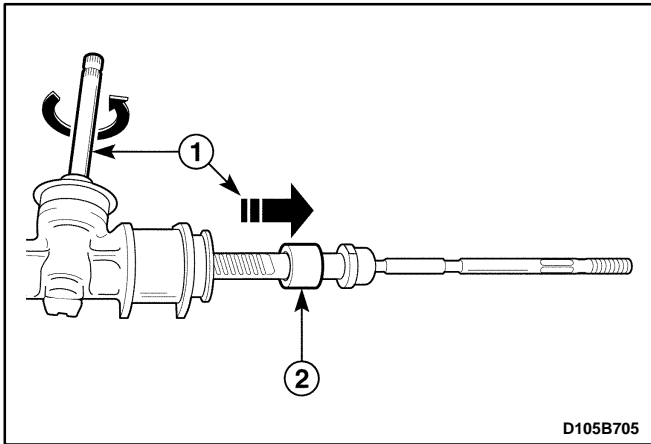

3. Remove the tie rod
- Pull the rack gear perfectly from the steering gear housing by turning the pinion gear (1).
 - Disconnect the shock damper ring from the tie rod ball joint (2).

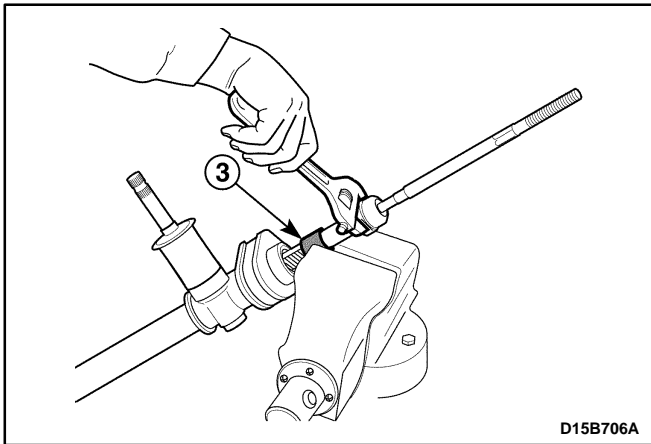

- Vise the rack gear (3).

Important: Cloth the rack gear with a cloth before vising the rack gear.

Notice: Do not vise the rack gear over two teeth face.

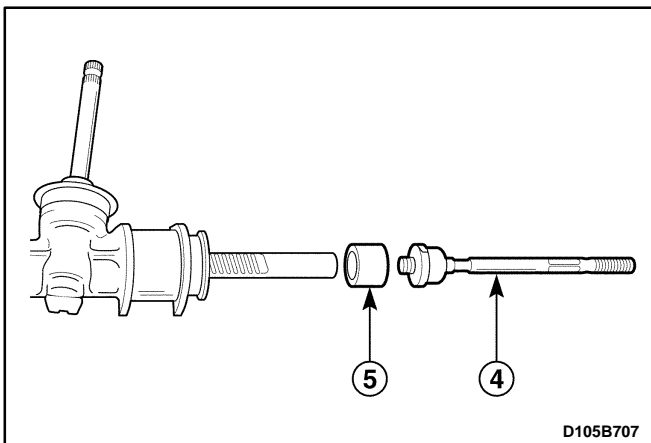

- Remove the tie rod (4).
- Remove the shock damper ring (5).

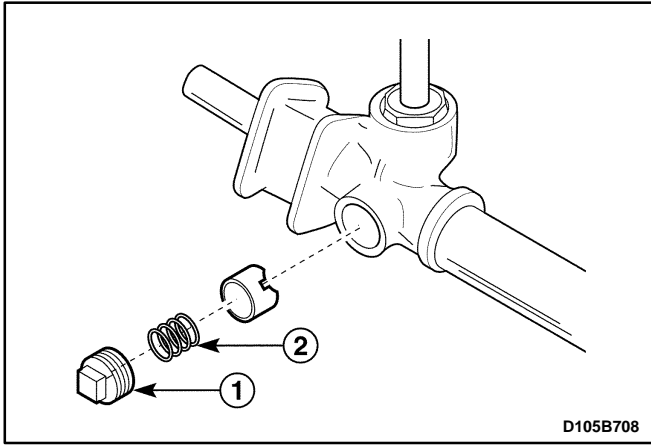

4. Remove the rack bearing.
 - Remove the adjuster plug (1).
 - Remove the adjuster spring (2).

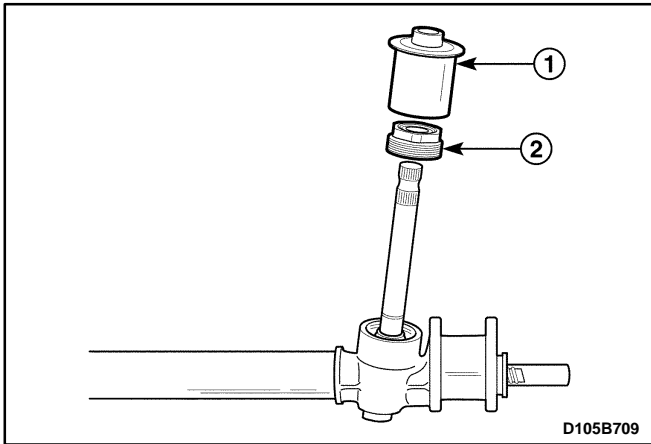

5. Remove the pinion and bearing assembly.
 - Remove the dust cover (1).
 - Remove the pinion plug (2).

Important: Do not reuse the removed pinion plug.

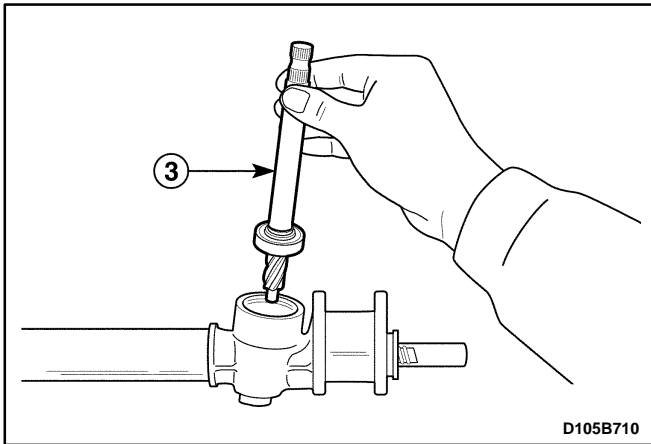

- Remove the pinion and bearing assembly (3).

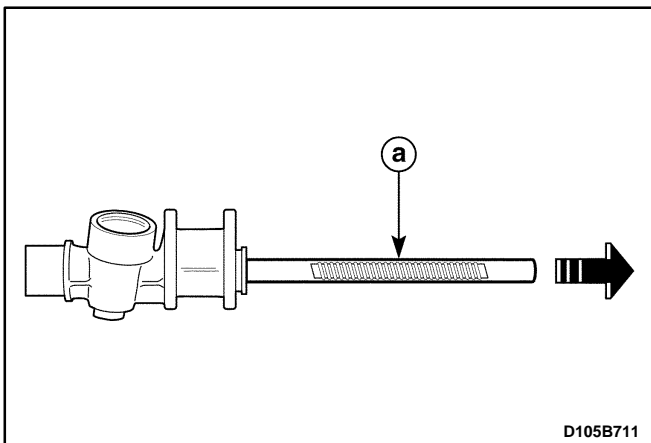

6. Remove the rack gear toward the driver side of the steering gear.
 - a. Rack gear.

Notice: Remove the rack gear toward the driver side of the steering gear to prevent the bulk head in the steering gear housing from damaging in installing and removing the rack gear.

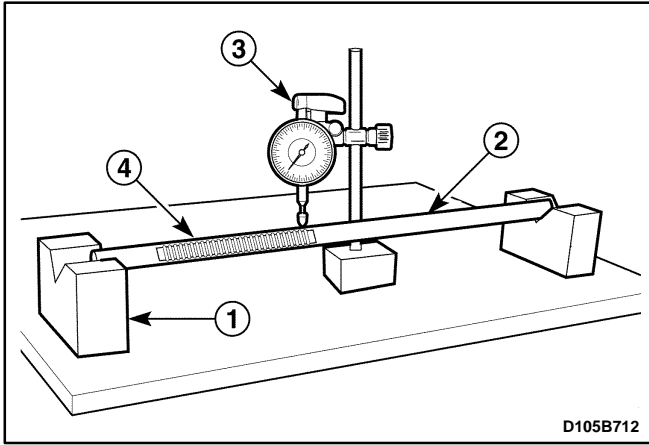

Inspection Procedure

1. Inspect the rack gear deformation and damage.
 - Set the V-block on the plate (1).
 - Set the rack gear on the V-block (2).
 - Check the rack gear for deformation using a dial gauge (3).
 - Inspect the rack gear for wear and damage (4).

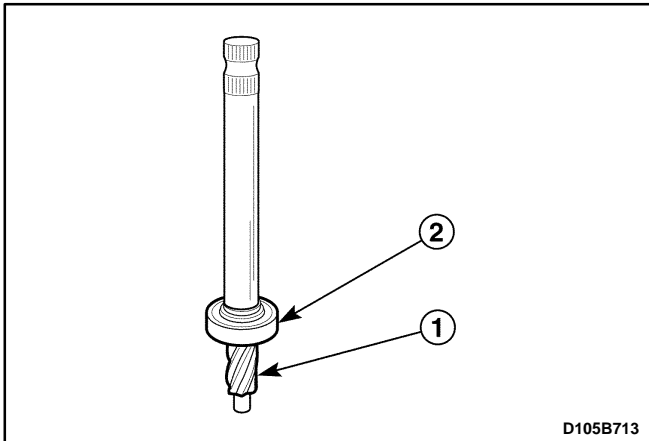

2. Inspect the pinion and bearing assembly damage.
 - Inspect the pinion gear for wear and damage (1).
 - Inspect the bearing for loose and operation (2).

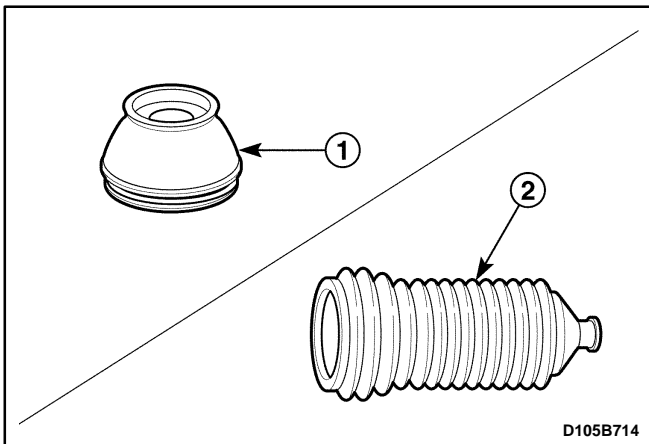

3. Inspect the tie rod end boot and the rack and pinion boot for damage.
 - Inspect the tie rod end boot for crack and wear (1).
 - Inspect the rack and pinion boot for crack and wear (2).

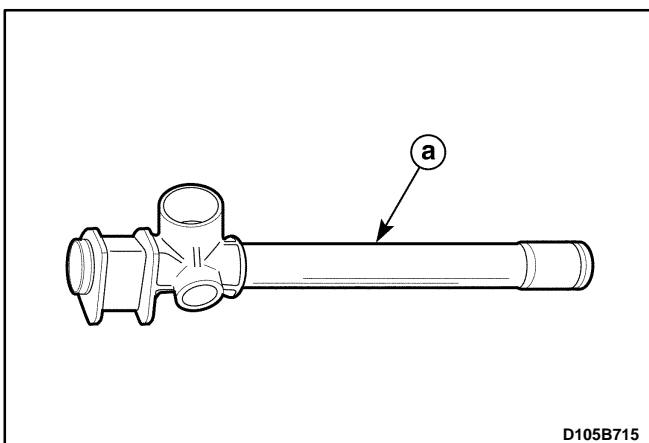

4. Inspect the steering gear housing for crack, deformation and wear.
 - a. Steering gear housing.

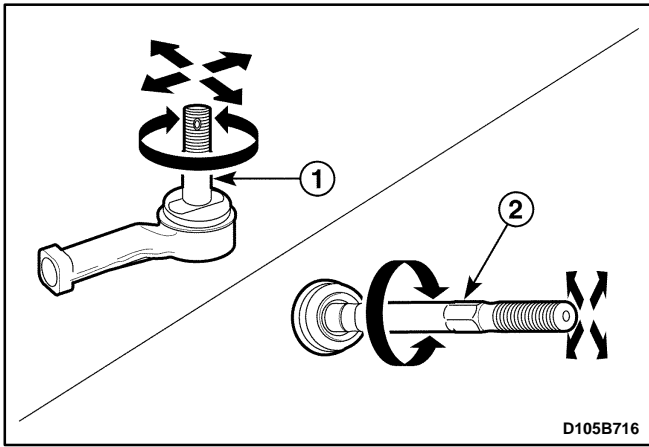

5. Inspect the tie rod end ball joint and tie rod ball joint for damage.
 - Inspect the tie rod end ball joint for operation (1).
 - Inspect the tie rod ball joint for operation and tie rod deformation (2).
6. After inspecting the parts, replace the defected parts.

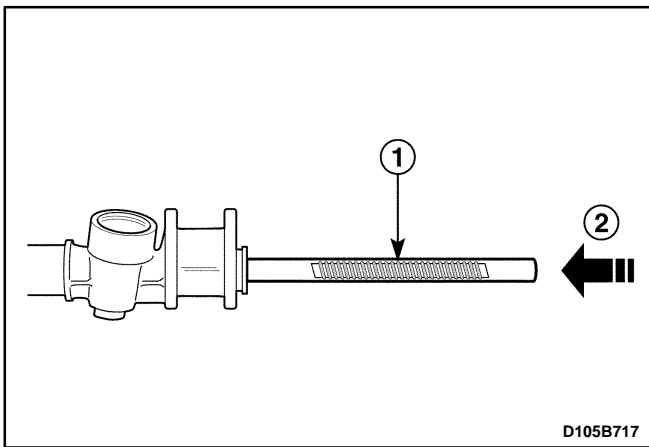

Assembly Procedure

Important: Coat the all turn, contact and rub surface with grease.

1. Clean the all parts removed.
2. Install the rack gear.
 - Coat the rack gear with grease (1).
 - Insert the rack gear carefully (2).

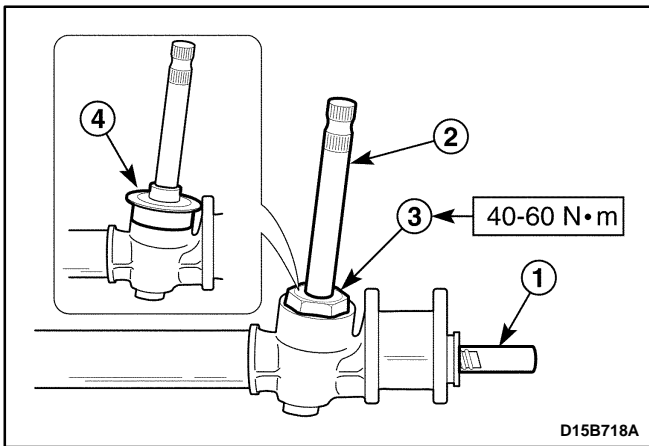

3. Install the pinion and bearing assembly.
 - Set the rack in balance (1).
 - Coat the pinion and bearing assembly and steering gear housing surface with grease.
 - Install the pinion and bearing assembly (2).
 - Coat the pinion plug with Loctite.
 - Install the pinion plug (3).

Tighten

Tighten the pinion plug to 40-60 N·m (30-44 lb-ft).

- Install the dust cover (4).



4. Install the rack bearing.
 - Coat the rack bearing with grease.
 - Install the rack bearing (1).
 - Install the adjuster spring (2).
 - Tighten the adjuster plug softly (3).

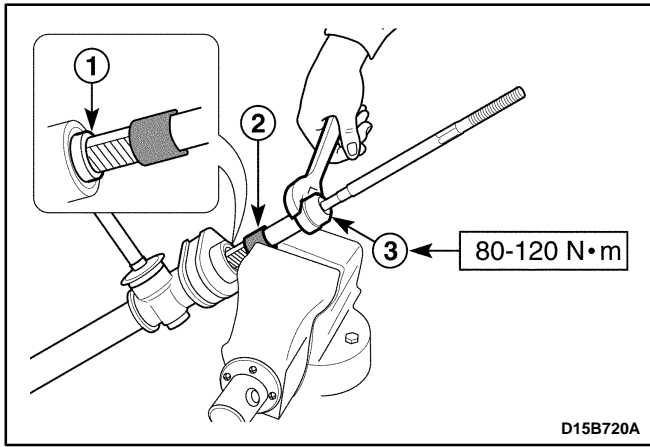

5. Install the tie rod.
 - Install the shock damper ring to the rack gear (1).
 - Vise the rack gear (2).

Important : Cloth the rack gear with a cloth before vising the rack gear.

Notice: Do not vise the rack gear above two teeth face.

- Coat the teeth face of the tie rod with Loctitte.
- Install the tie rod (3).

Tighten

Tighten the tie rod to 80–120 N•m (59–89 lb-ft).

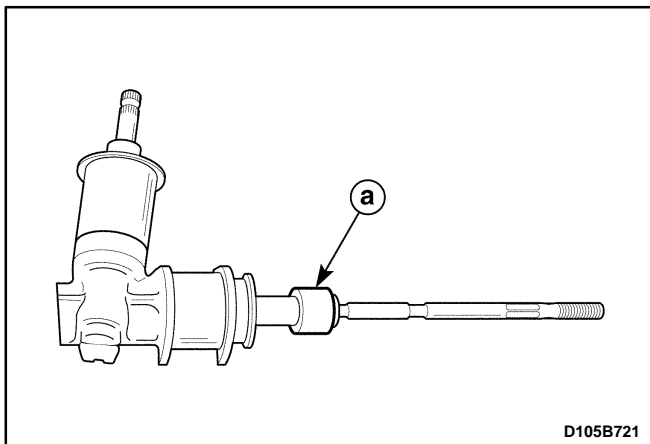

6. Install the shock damper ring to the tie rod ball joint.
 - a. Tie rod ball joint.
 - Coat the tie rod ball joint with grease.

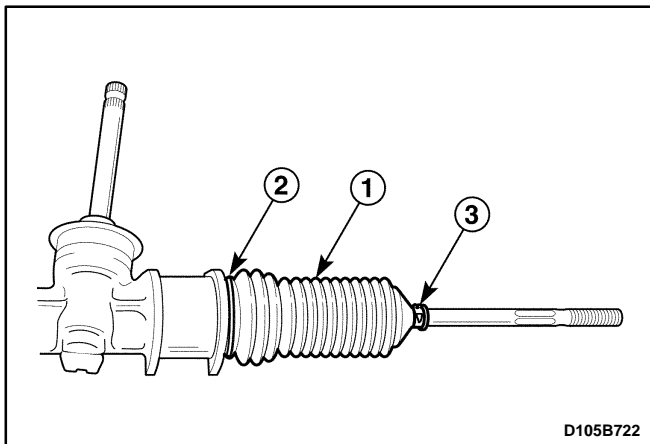

7. Install the rack and pinion boot.
 - Install the rack and pinion boot (1).
 - Install the rack and pinion boot wire clamp (2).
 - Install the rack and pinion boot clamp (3).
8. Install the tie rod end. Refer to “Tie Rod End” in this sections.
9. Install the rack and pinion steering gear assembly to the vehicle. Refer to “Rack and Pinion Steering Gear Assembly” in this section.
10. Adjust the free load of the steering gear. Refer to “Diagnosis” in this section.

SPECIFICATIONS

GENERAL SPECIFICATIONS

Application			Description
Type			Rack and Pinion
Overall Gear Ratio			21 : 1
Steering Angle	145,155 Tire	Inside	$39.5^{\circ} \pm 2^{\circ}$
		Outside	$33.5^{\circ} \pm 2^{\circ}$
	175 Tire	Inside	$34.9^{\circ} \pm 2^{\circ}$
		Outside	$30.5^{\circ} \pm 2^{\circ}$
Lubricant	Rack Gear		POLYUREAS
	Ball Joint		SYNTHETICS OILS & LI SOAPS
Locktite Type			DAC SPEC ADHESIVE SEALANT #520414

FASTENER TIGHTENING SPECIFICATIONS

Application	N•m	Lb-Ft	Lb-In
Tie Rod End Castellated Nut	30 – 55	21 – 41	–
Tie Rod End Lock Nut	35 – 55	25 – 41	–
Steering Gear Bracket Bolts	50 – 55	36 – 41	–
Tie Rod-to-Rack Gear	80 – 120	59 – 89	–
Pinion Plug	40 – 60	30 – 44	–
Pinion Preload	Refer to "Diagnosis" in this section.		

SPECIAL TOOLS AND EQUIPMENT

SPECIAL TOOLS TABLE

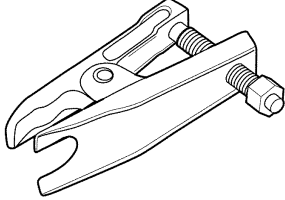
 <p>D105B101</p>	<p>KM-507-B Ball Joint Remover</p>
---	--