SECTION 5B

FIVE-SPEED MANUAL TRANSAXLE

CAUTION: Disconnect the negative battery cable before removing or installing any electrical unit or when a tool or equipment could easily come in contact with exposed electrical terminals. Disconnecting this cable will help prevent personal injury and damage to the vehicle. The ignition must also be in B unless otherwise noted.

TABLE OF CONTENTS

Description and Operation	5B-2	On-Vehicle Service	5B-10
Five-Speed Manual Transaxle	5B-2	Manual Transaxle Assembly	5B-10
Reverse Gear Misshift Preventing Mechanism	5B-2	Gear Shift Control Case Assembly	5B-17
Differential	5B-2	Speedometer Driven Gear and Cable	5B-19
Component Locators	5B-3	Gear Shift Control Cable	5B-21
Gear Shift Control	5B-3	Gear Shift Control Lever	5B-23
Input Shaft and Counter Shaft Gear	5B-4	Unit Repair	5B-24
Gear Shift Fork	5B-6	Gear Unit	5B-24
Differential and Case	5B-7	Input Shaft	5B-36
Diagnostic Information and Procedure	5B-8	Counter Shaft	5B-41
General Diagnosis	5B-8	Gear Shift Fork	5B-46
Checking Fluid Level	5B-9	Differential	5B-48
Changing Fluid	5B-9	Specifications	5B-52
Checking Transaxle Noise	5B-9	General Specifications	5B-52
Checking Bearing Noise	5B-9	Fastener Tightening Specifications	5B-53
Repair Instruction	5B-10	Special Tools	5B-54
		Special Tools Table	5B-54

DESCRIPTION AND OPERATION

FIVE-SPEED MANUAL TRANSAXLE

This five-speed transaxle assembly adopts the synchronized mesh type of 5 forward speed. The reverse speed gear is driven by sliding idle gear without synchronizer.

REVERSE GEAR MISSHIFT PREVENTING MECHANISM

It prevents the gear from directly being shifted from 5th to reverse when shifting to reverse from 5th. Shift to the reverse in neutral position to prevent the shift cam from being interfered to the shift guide bolt.

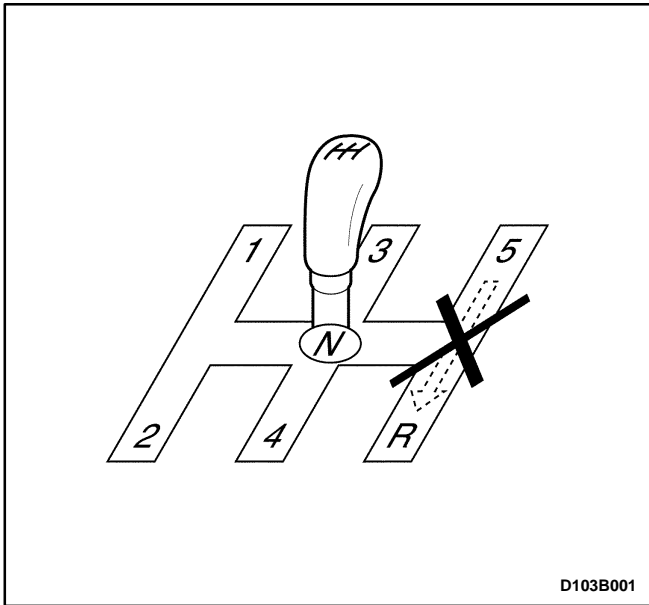

In case of shifting to 5th gear, shift and select shaft rotates to right that shift cam aparts from guide bolt and moves upwards by returning spring. Therefore, shifting to reverse in this condition is impossible because of interference of guide bolt.

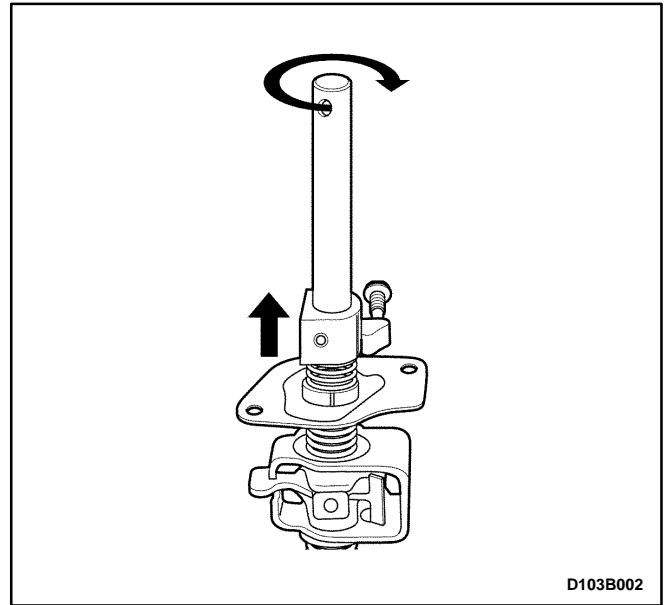

When shifting to reverse from neutral position between 5th and reverse, shift cam rotates to left and shifting is possible.

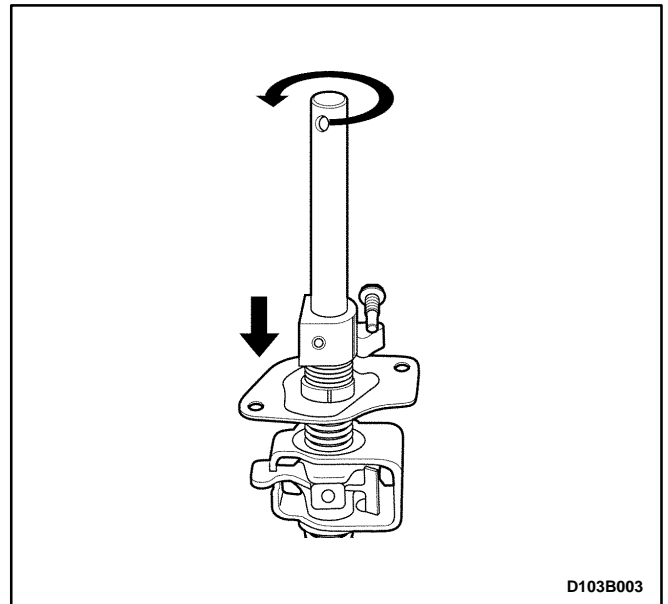

DIFFERENTIAL

Differential is integrated with transmission case and installed on chassis together with engine. It changes the direction of power and increase torque by reducing speed.

Reduction gear is installed parallel to counter shaft and is helical gear type. Differential gear is bevel gear type and is integrated with reduction gear.

COMPONENT LOCATORS

GEAR SHIFT CONTROL

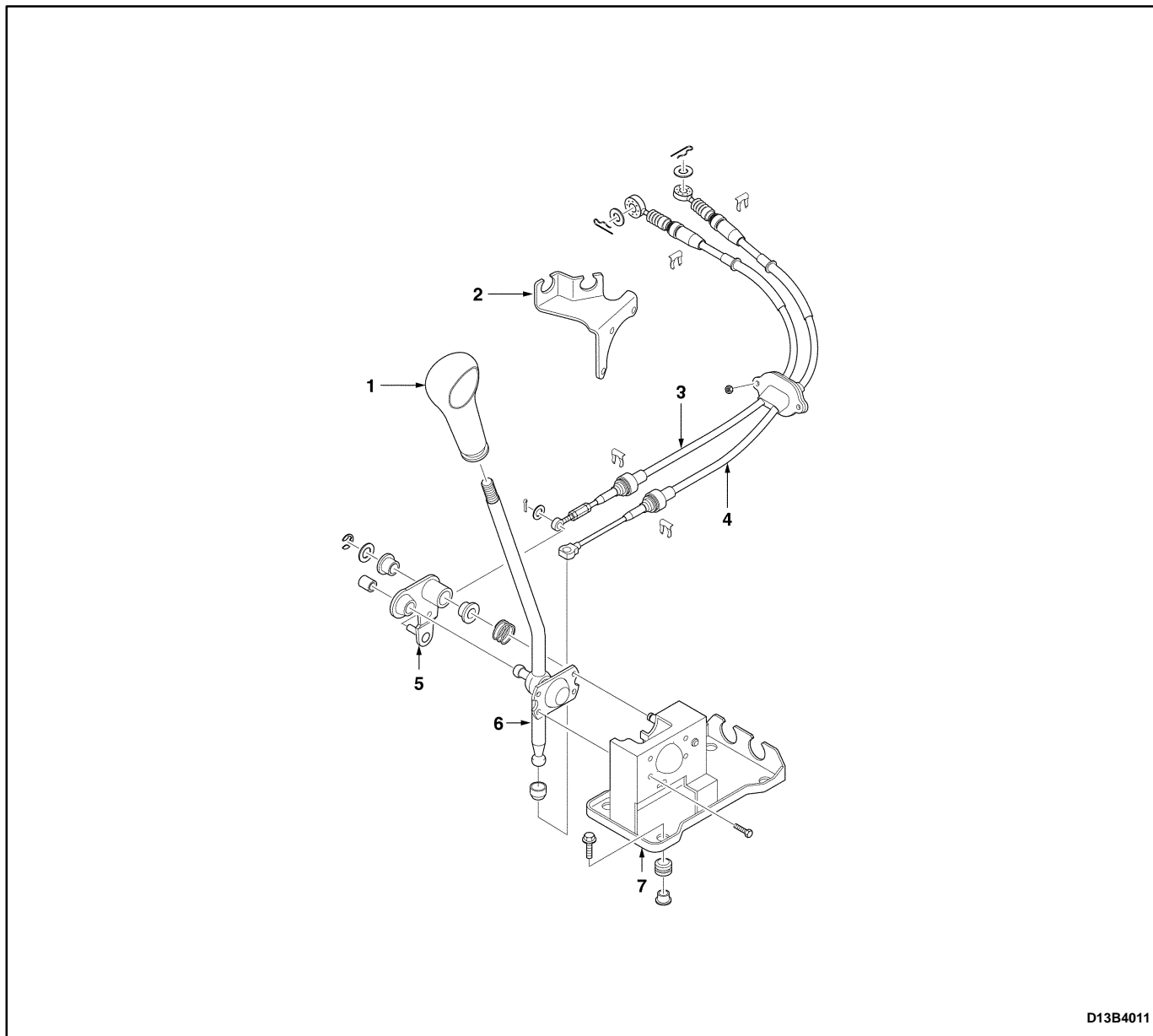

D13B4011

- 1 Gear Shift Control Lever Knob
- 2 Gear Shift Cable Bracket
- 3 Select Cable
- 4 Shift Cable

- 5 Select Arm
- 6 Gear Shift Control Lever
- 7 Gear Shift Control Lever Guide

INPUT SHAFT AND COUNTER SHAFT GEAR

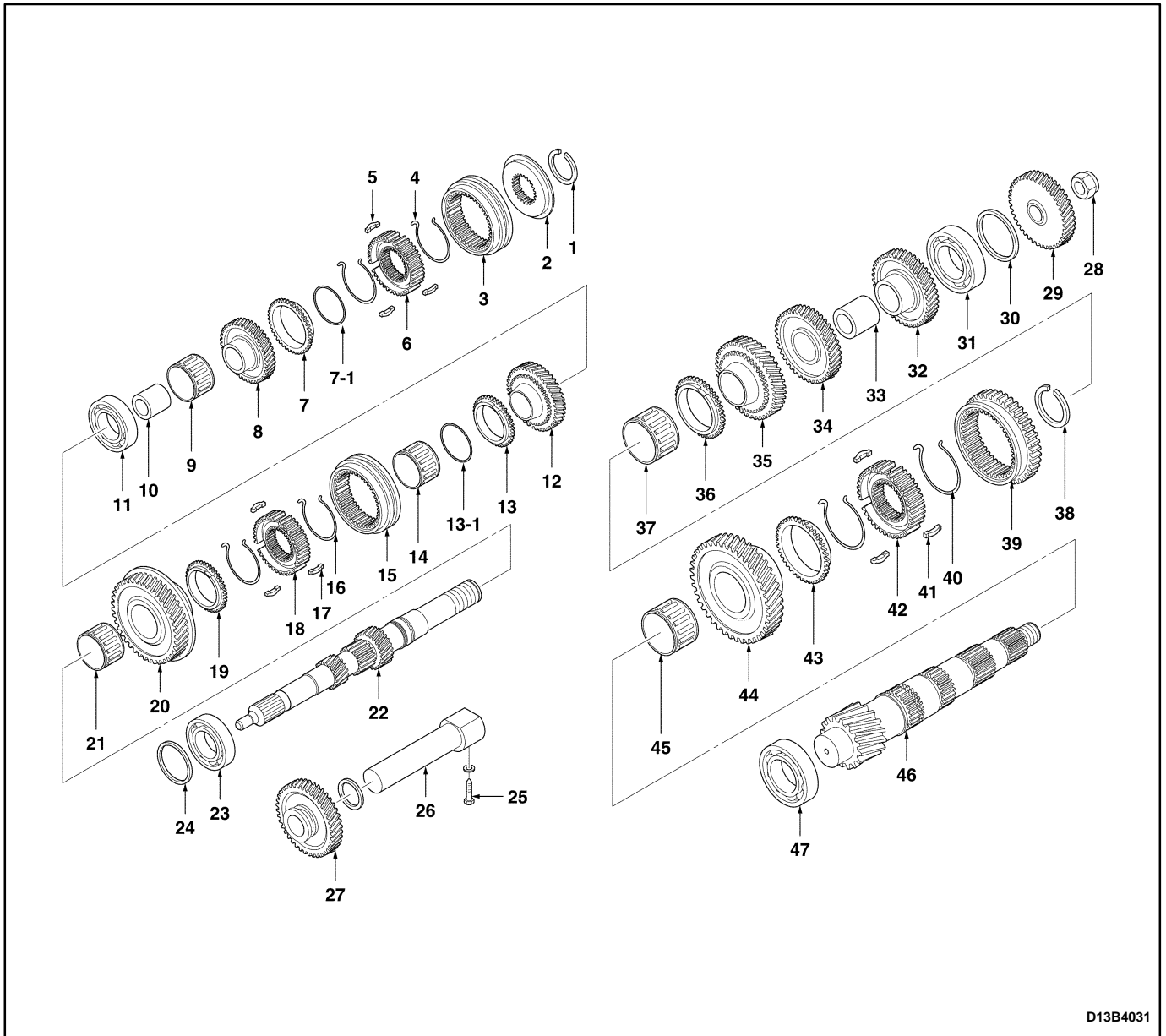

D13B4031

- | | | | |
|------|----------------------------------|----|-----------------------------------|
| 1 | Input Shaft Circlip | 24 | Input Shaft Oil Seal |
| 2 | 5th Gear Synchronizer Plate | 25 | Reverse Gear Shaft Bolt |
| 3 | 5th Gear Synchronizer Sleeve | 26 | Reverse Gear Shaft |
| 4 | 5th Gear Synchronizer Spring | 27 | Reverse Idle Gear |
| 5 | 5th Gear Synchronizer Key | 28 | Counter Shaft Nut |
| 6 | 5th Gear Synchronizer Hub | 29 | Counter Shaft 5th Gear |
| 7 | 5th Gear Synchronizer Ring | 30 | Counter Shaft Bearing Shim |
| 7-1 | Wave Spring | 31 | Counter Shaft Bearing(Left) |
| 8 | Input Shaft 5th Gear | 32 | Counter Shaft 4th Gear |
| 9 | Input Shaft 5th Gear Bearing | 33 | Counter Shaft 3rd-4th Gear Spacer |
| 10 | Input Shaft 5th Gear Spacer | 34 | Counter Shaft 3rd Gear |
| 11 | Input Shaft Bearing(Left) | 35 | Counter Shaft 2nd Gear |
| 12 | Input Shaft 4th Gear | 36 | 2nd Gear Synchronizer Ring |
| 13 | 4th Gear Synchronizer Ring | 37 | Counter Shaft 2nd Gear Bearing |
| 13-1 | Wave Spring | 38 | 1st-2nd Gear Synchronizer Circlip |
| 14 | Input Shaft 4th Gear Bearing | 39 | 1st-2nd Gear Synchronizer Sleeve |
| 15 | 3rd-4th Gear Synchronizer Sleeve | 40 | 1st-2nd Gear Synchronizer Spring |
| 16 | 3rd-4th Gear Synchronizer Spring | 41 | 1st-2nd Gear Synchronizer Key |
| 17 | 3rd-4th Gear Synchronizer Key | 42 | 1st-2nd Gear Synchronizer Hub |
| 18 | 3rd-4th Gear Synchronizer Hub | 43 | 1st Gear Synchronizer Ring |
| 19 | 3rd Gear Synchronizer Ring | 44 | Counter Shaft 1st Gear |
| 20 | Input Shaft 3rd Gear | 45 | Counter Shaft 1st Gear Bearing |
| 21 | Input Shaft 3rd Gear Bearing | 46 | Counter Shaft |
| 22 | Input Shaft | 47 | Counter Shaft Bearing(Right) |
| 23 | Input Shaft Bearing(Right) | | |
-

GEAR SHIFT FORK

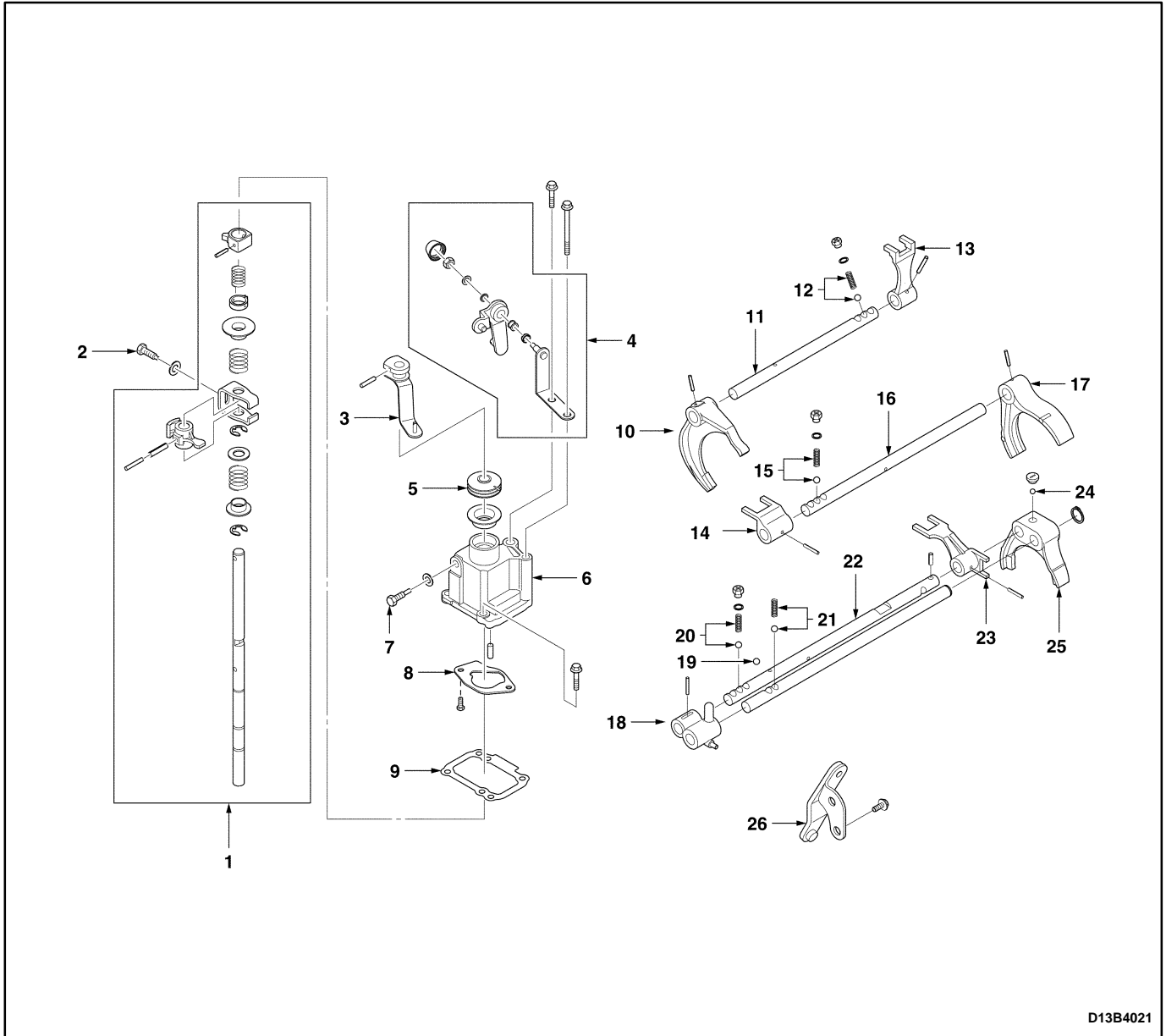

D13B4021

- | | |
|--------------------------------------|--|
| 1 Shift and Select Shaft | 14 High Speed Shift York |
| 2 Shift Interlock Bolt | 15 High Speed Shaft Spring/Ball |
| 3 Shift Lever | 16 High Speed Shift Shaft |
| 4 Select Lever | 17 High Speed Shift Fork |
| 5 Shift and Select Shaft Boot | 18 Reverse Shift Arm |
| 6 Gearshift Control Case | 19 5th/Reverse Shift Ball |
| 7 Shift Guide Bolt | 20 5th/Reverse Shift Shaft Spring/Ball |
| 8 Gearshift Control Case Guide Plate | 21 Reverse Shift Shaft Guide Spring/Ball |
| 9 Gearshift Control Case Gasket | 22 5th/Reverse Shift Shaft |
| 10 Low Speed Shift Fork | 23 5th/Reverse Shift York |
| 11 Low Speed Shift Shaft | 24 5th/Shift Fork Guide Ball |
| 12 Low Speed Shift Shaft Spring/Ball | 25 5th/Shift Fork |
| 13 Low Speed Shift York | 26 Reverse Shift Lever |

DIFFERENTIAL AND CASE

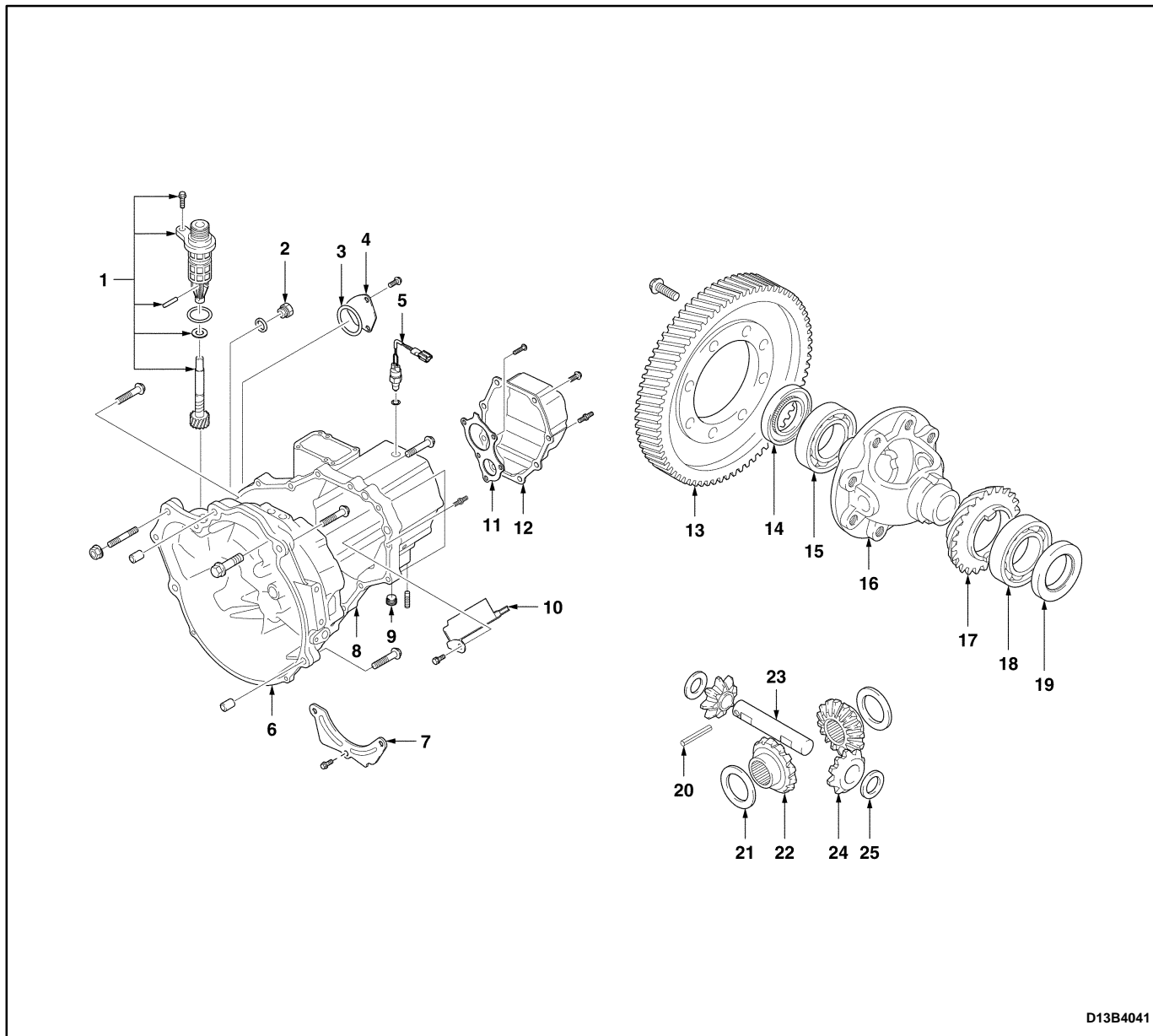

D13B4041

- | | |
|---------------------------|---------------------------------------|
| 1 Speedometer Driven Gear | 14 Differential Oil Seal(Left) |
| 2 Oil Level Plug | 15 Differential Bearing(Left) |
| 3 Case Cap O-ring(Left) | 16 Differential Case |
| 4 Case Cap(Left) | 17 Speedometer Drive Gear |
| 5 Back Up Light Switch | 18 Differential Bearing(Right) |
| 6 Transaxle Case(Right) | 19 Differential Oil Seal(Right) |
| 7 Oil Plate | 20 Differential Pinion Gear Shaft Pin |
| 8 Transaxle Case(Left) | 21 Differential Side Gear Adjust Shim |
| 9 Oil Drain Plug | 22 Differential Side Gear |
| 10 Oil Gutter | 23 Differential Pinion Gear Shaft |
| 11 Side Cover Plate | 24 Differential Pinion Gear |
| 12 Side Cover | 25 Differential Pinion Gear Washer |
| 13 Differential Ring Gear | |

DIAGNOSTIC INFORMATION AND PROCEDURE

GENERAL DIAGNOSIS

Condition	Probable Cause	Correction
Gear Slipping Out of Mesh	• Worn shift fork.	• Replace shift fork.
	• Worn synchronizer sleeve or gear.	• Replace sleeve or gear.
	• Worn bearings on input shaft or counter shaft.	• Replace bearing.
	• Weakened or damaged location spring.	• Replace spring.
	• Loose or damaged synchronizer spring.	• Replace synchronizer spring.
	• Excessive back-lash of gear.	• Adjust back-lash of gear.
Gear Catching	• Bent or distorted shift shaft or shift fork.	• Replace shift shaft or shift fork.
	• Weakened or damaged synchronizer spring.	• Replace spring.
Hard Shifting	• Worn synchronizer ring.	• Replace synchronizer ring.
	• Worn synchronizer sleeve or gear.	• Replace sleeve or gear.
	• Bent or distorted shift shaft.	• Replace shift shaft.
	• Excessive free travel of all gears in axial direction.	• Replace gear.
	• Worn bearings on input shaft or counter shaft.	• Replace bearing.
	• Poor adjustment of clutch cable.	• Adjust clutch cable.
	• Distorted or broken clutch disc.	• Replace clutch disc.
	• Damaged pressure plate.	• Replace pressure plate.
Noise in the Neutral Gear	• Insufficient lubricant.	• Supply lubricant.
	• Worn input shaft gear.	• Replace gear.
	• Worn bearings on the input shaft gears.	• Replace bearing.
	• Worn clutch release bearing.	• Replace clutch release bearing.
Noise in the All Gears	• Insufficient lubricant.	• Supply lubricant.
	• Worn bearings on input shaft or counter shaft.	• Replace bearing.
	• Worn input shaft or counter shaft gear.	• Replace gear.
	• Worn or damaged synchronizer ring.	• Replace synchronizer ring.
	• Worn or damaged synchronizer sleeve.	• Replace synchronizer sleeve.
	• Worn differential gear or bearing.	• Replace gear or bearing.
Noise in the Peculiar Gear	• Worn or damaged synchronizer ring in the peculiar gear.	• Replace synchronizer ring.
	• Worn or damaged gear in the peculiar gear.	• Replace gear.
	• Worn or damaged bearing in the peculiar gear.	• Replace bearing.
Leak of Lubricant	• Damaged gasket, oil seal or O-ring.	• Replace gasket, oil seal or O-ring.

CHECKING FLUID LEVEL

Check for a leak in the area of transaxle case and sealing and then check fluid level and condition after removing oil level plug.

1. Operate the engine until it comes to normal operating temperature (Coolant temperature : 80~90°C (176~194°F)).
2. Stall the engine and raise the vehicle.
3. Remove the oil level plug and check the fluid level.
4. The fluid should slightly flow out from the oil level plug hole.
5. If the level is low, add the recommended fluid through the oil level plug hole until the fluid begins to run out.
6. If the fluid is contaminated or discolored, replace it with the recommended fluid.
7. Reinstall the oil level plug and tighten it securely.

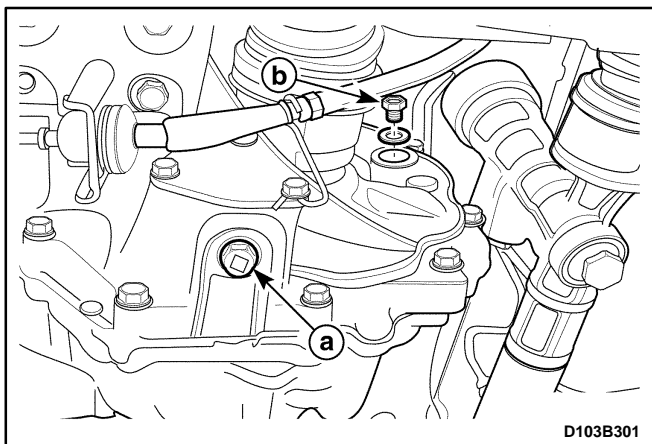

CHANGING FLUID

1. Operate the engine until it comes to normal operating temperature (Coolant temperature : 80~90°C (176~194°F)).
2. Stall the engine and raise the vehicle.
3. Drain the fluid after removing the drain plug.
4. Reinstall the drain plug and tighten it securely after coating sealant.
5. Remove the oil level plug and replenish the fluid until it begins to run out.
 - a. Oil drain plug.
 - b. Oil level plug.
6. Reinstall the oil level plug and tighten it securely.

Fluid Specification	75W-85(GL-4)
Fluid Capacity	2.1L(2.21qt)
Service interval	Refer to Owner's Manual

CHECKING TRANSAXLE NOISE

Many noises that appear to come from the transaxle may actually originate with other sources such as tires, road surfaces, wheel bearings, or engine and exhaust system.

Identify the cause of any noise before attempting to repair the clutch, the transaxle, or their related linkages.

To verify suspected transaxle noises,

1. Select a smooth, level asphalt road to reduce tyre and resonant body noise.
2. Drive the vehicle far enough to warm up all the lubricants thoroughly.
3. Record the speed and the gear range of the transaxle when the noise occurs.
4. Check for noises with the vehicle stopped, but with the engine running.
5. Determine if the noise occurs while the vehicle operates in.
 - Drive – Under a light acceleration or a heavy pull.
 - Float – Maintaining a constant speed with a light throttle on a level road.
 - Coast – With the transaxle in gear and the throttle partly or fully closed.
 - All of the above.

CHECKING BEARING NOISE

Differential Side Bearing Noise

Differential side bearing noise and wheel bearing noise can be confused easily. Since side bearings are pre-loaded, a differential side bearing noise should not diminish much when the differential/transaxle is run with the wheels off the ground.

Wheel Bearing Noise

Wheel bearings produce a rough growl or grating sound that will continue when the vehicle is coasting and the transaxle is in NEUTRAL. Since wheel bearings are not pre-loaded, a wheel bearing noise should diminish considerably when the wheels are off the ground.

REPAIR INSTRUCTION

ON-VEHICLE SERVICE

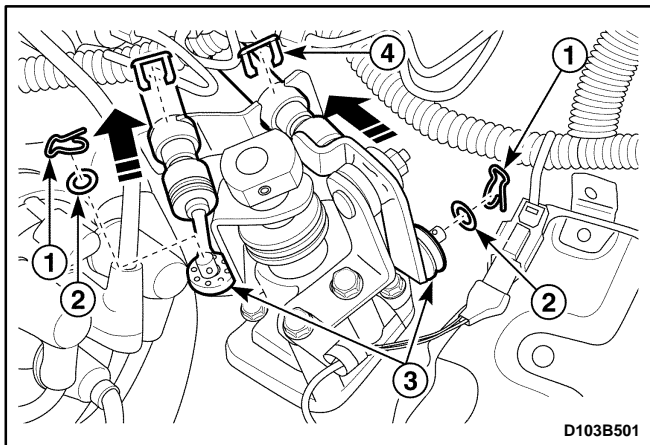

MANUAL TRANSAXLE ASSEMBLY

Tools Required

DW110-021 Engine Support Fixture

DW220-031 Transaxle Remove/Install Support

Removal Procedure

1. Remove the air cleaner assembly. Refer to *Section 1B, SOHC Engine Mechanical*.
2. Remove the battery and battery tray. Refer to *Section 1E, Engine Electrical*.
3. Disconnect the select and the shift cable.
 - Remove the cable pins (1).
 - Remove the washers (2).
 - Disconnect the select and the shift cable (3).
 - Remove the cable E-rings (4).
 - Disconnect the cables from the cable bracket.

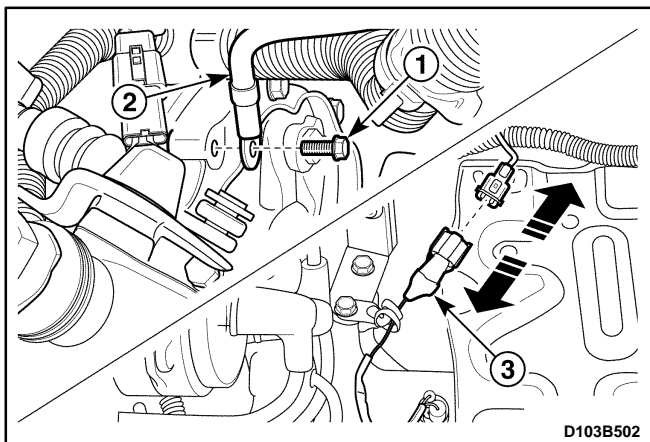

4. Remove the engine wiring harness bending strap.
5. Disconnect the ground wire and the backup lamp switch connector.
 - Remove the ground wire bolt (1).
 - Disconnect the ground wire (2).
 - Disconnect the backup lamp switch connector (3).

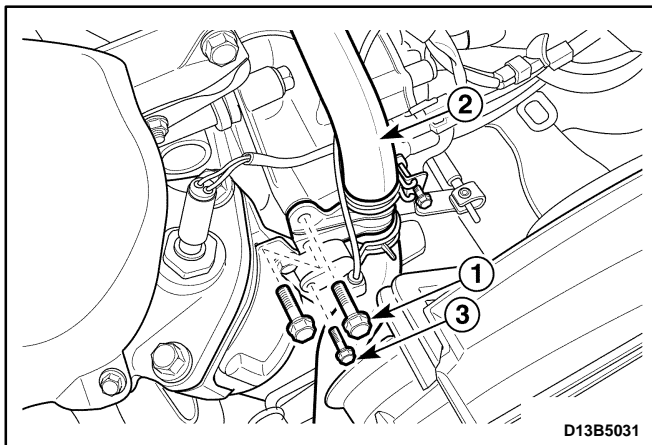

6. Disconnect the radiator lower hose.
 - Remove the bolts (1).
 - Disconnect the radiator lower hose (2).
7. Remove crankshaft position (CKP) sensor.
 - Remove the bolt (3).
 - Disconnect the CKP sensor connector
 - Remove the CKP sensor.

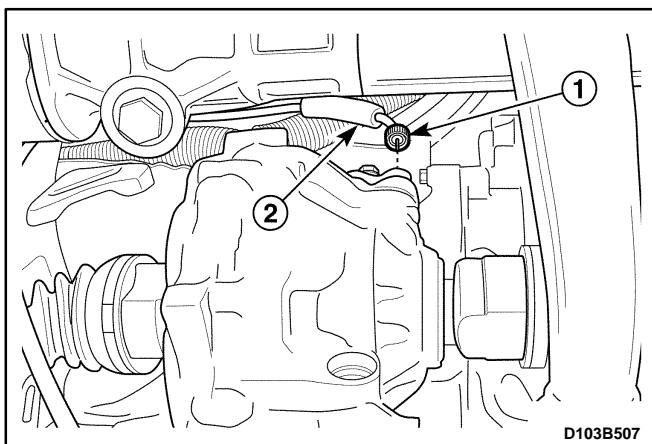

8. Disconnect the speedometer cable.
 - Loosen the nut (1).
 - Disconnect the cable (2).
9. Remove the vehicle speed sensor (VSS) if equipped.
 - Disconnect VSS connector.
 - Remove the VSS.

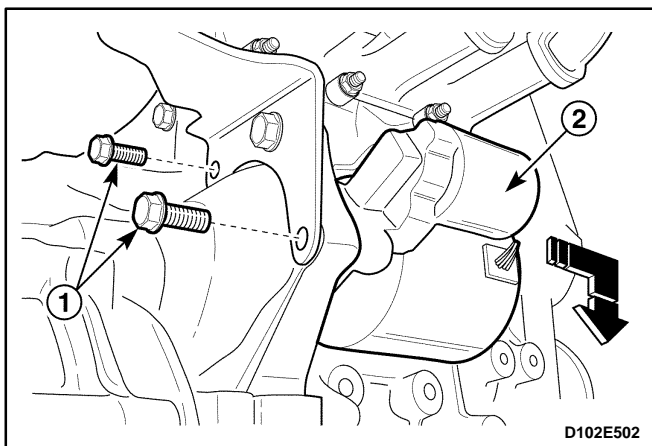

10. Remove the starter motor.
 - Remove upper two bolts that securing starter motor to transaxle.

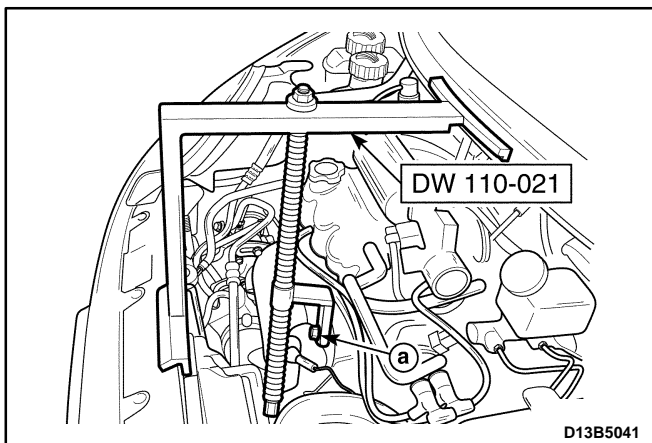

11. Fix the engine assembly.
 - Remove the cowl panel weatherstrip.
 - Position the engine support fixture DW110-021 on the cowl panel and the front upper panel.
 - Tighten the engine fixture joint with a bolt after removing exhaust manifold bolt (No.4).

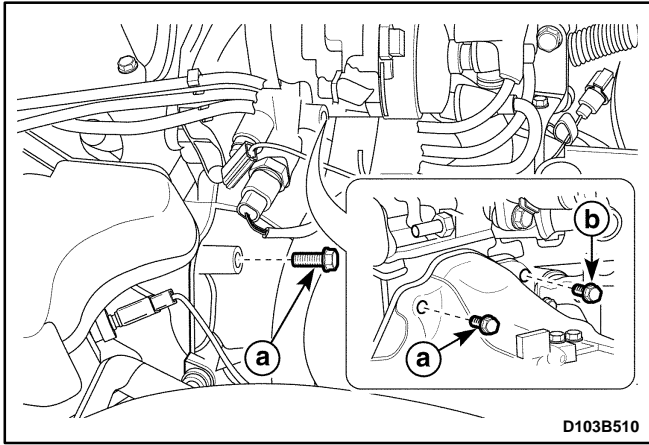

12. Remove the transaxle upper bolts.
 - a. Exhaust manifold side bolt.
 - b. Thermostat housing side bolt.

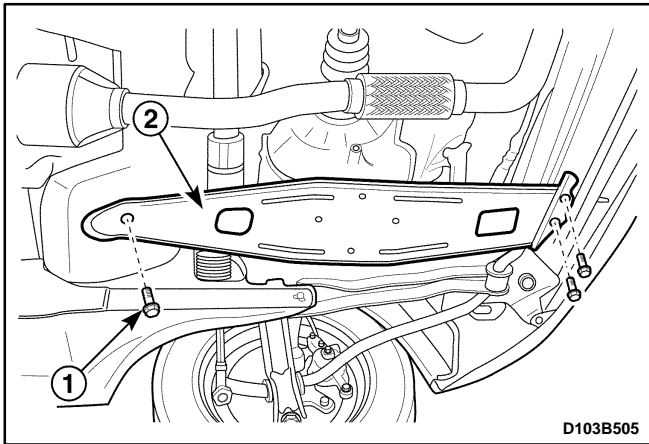

13. Remove the transaxle under cover.
 - Remove the bolts (1).
 - Remove the transaxle under cover (2).
14. Remove the front tires and wheels.

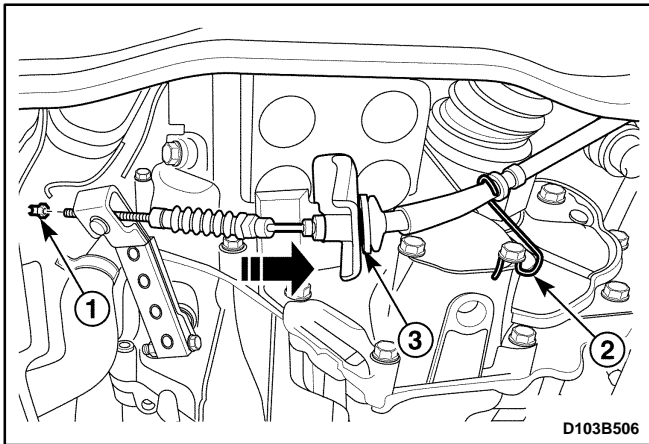

15. Drain the transaxle fluid.
 - Remove the drain plug and drain the fluid.
16. Disconnect the clutch cable.
 - Remove the cable adjust nut (1).
 - Disconnect the cable from the wire clip (2).
 - Disconnect the cable from the transaxle mount hole (3).

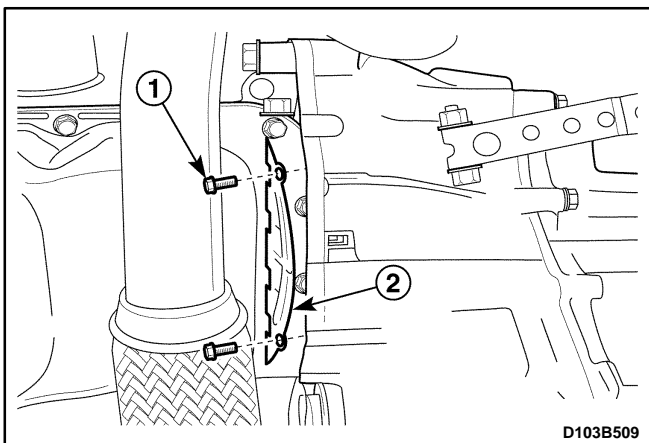

17. Remove the front under longitudinal frames and stabilizer. Refer to *Section 2C, Front Suspension*.
18. Remove the drive axle (only transaxle side). Refer to *Section 3B, Manual Transaxle Drive Axle*.
19. Remove the clutch housing lower plate.
 - Remove the bolts (1).
 - Remove the lower plate (2).

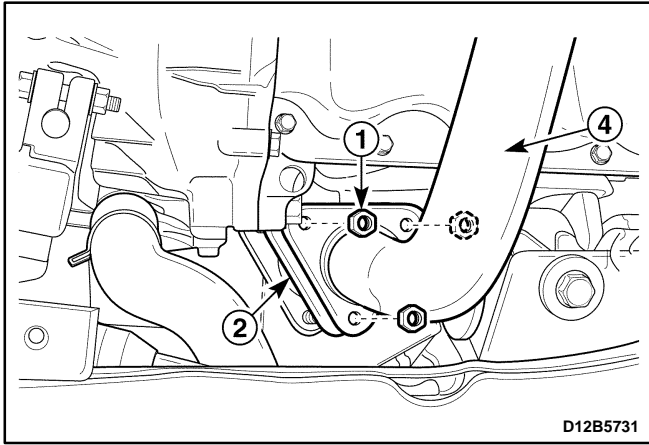

20. Remove the front exhaust pipe.
- Remove the front exhaust pipe nuts (exhaust manifold side) (1).
 - Remove the gasket and separate exhaust manifold pipe (2).
 - Make free the front exhaust pipe.

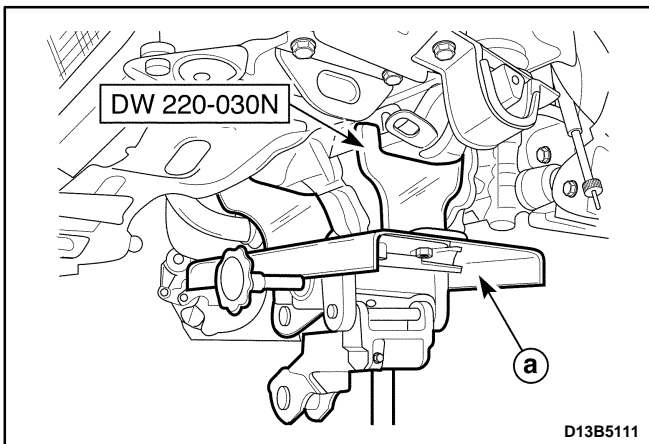

21. Support the transaxle with the transaxle remove/install support DW220-030N.
- Position the support on the jack (a).
 - Support the transaxle case and mount using a jack and the transaxle remove/install support.

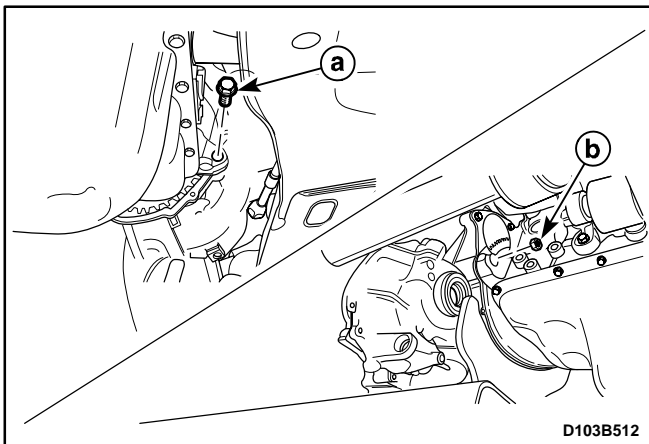

22. Remove the transaxle lower bolt and nut.
- a. Lower bolt.
 - b. Lower nut.

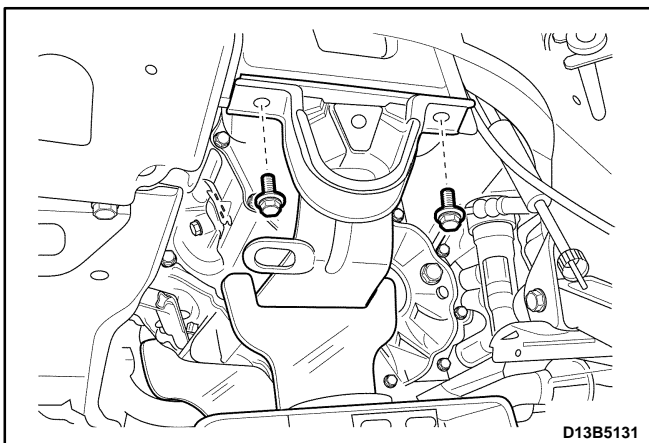

23. Remove the transaxle mount bolts.

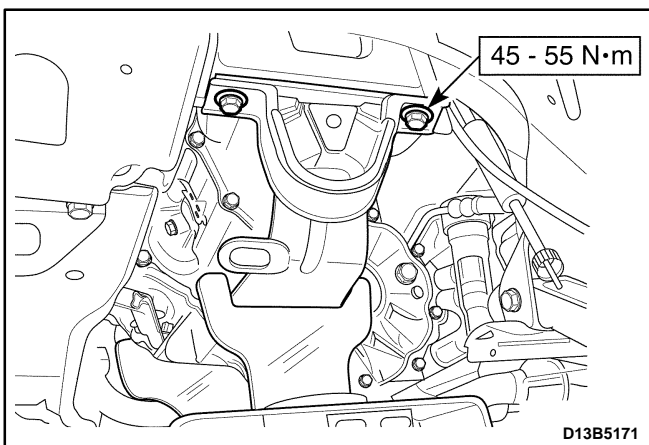
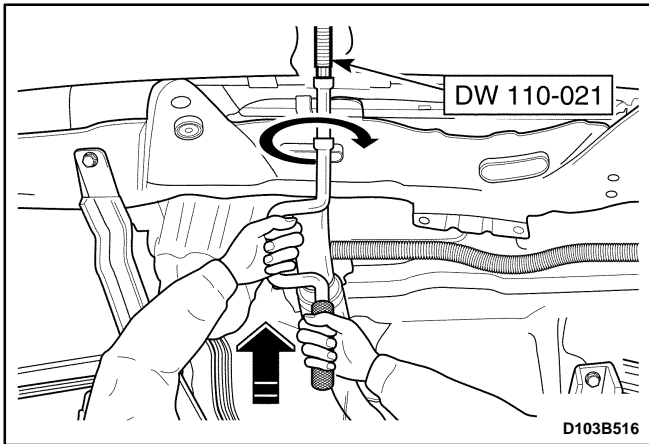
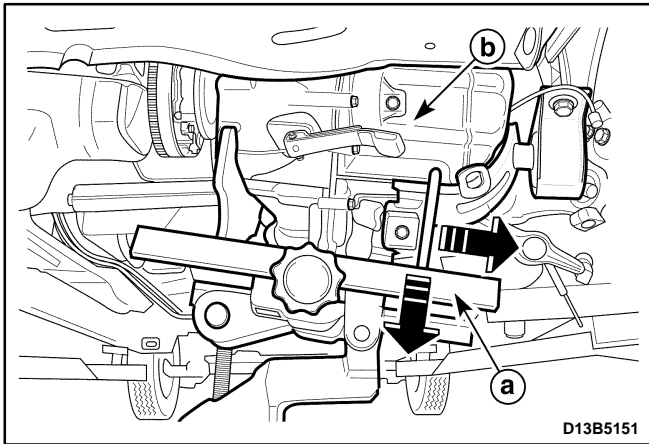
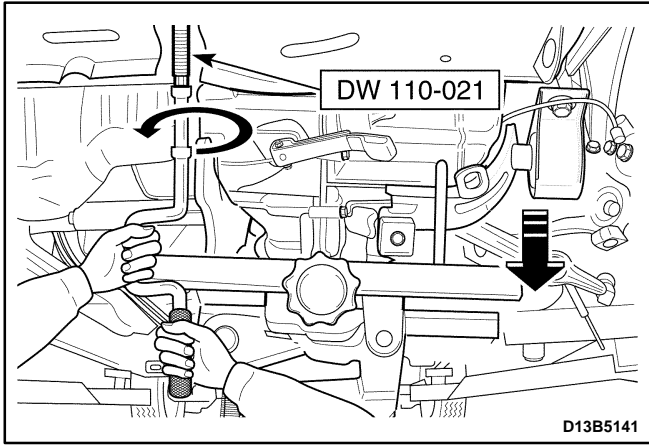

24. Position the manual transaxle assembly in tilting.
- To remove the manual transaxle side cover without the interference with the front under longitudinal panel (Left), tilt the engine/manual transaxle by loosening the engine support fixture DW110-021 joint with the wrench.

25. Remove the manual transaxle assembly.
- Lower the transaxle assembly slowly by adjusting jack.
 - a. Jack.
 - b. Transaxle assembly.
 - Tilt the transaxle assembly by adjusting jack.
 - Remove the transaxle assembly by pulling and lowering it slowly.

26. Support the engine to normal position using the engine support fixture DW110-021.

Notice: The abnormal position of the engine may damage to the related parts or interfere with them. You have to support the engine to normal position when removing the transaxle.

Important: If it is impossible to use the special tool, support the engine to normal position with the auto jack.

Installation Procedure

1. Install in the reverse order of removal.
2. Install the transaxle mounting bolts.

Tighten

Tighten the transaxle mounting bolts (body side) to 45-55 N·m (33-41 lb-ft).

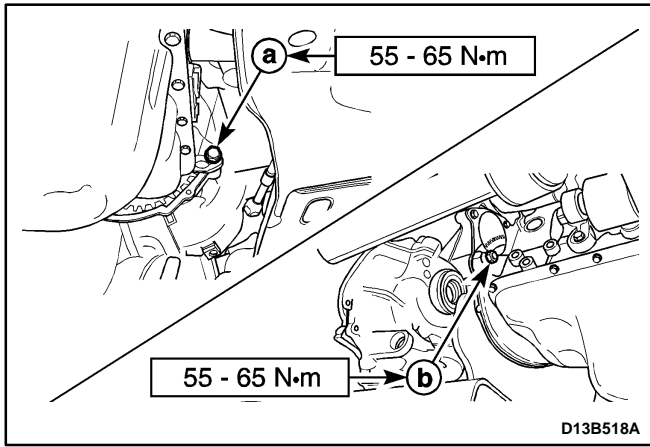

3. Install the transaxle lower bolt, nut.

Tighten

Tighten the bolt and nut to 55–65 N·m (41–48 lb-ft).

- a. Lower bolt.
- b. Lower nut.

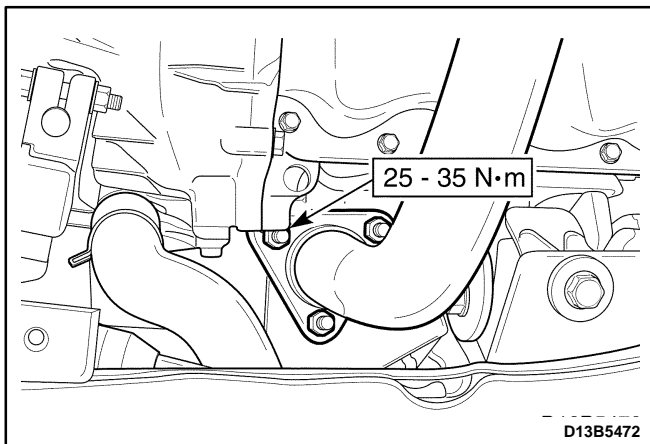

4. Tighten the front exhaust pipe nuts.

Tighten

- Tighten the front exhaust pipe nuts (exhaust manifold side) to 25–35 N·m (18–25 lb-ft).

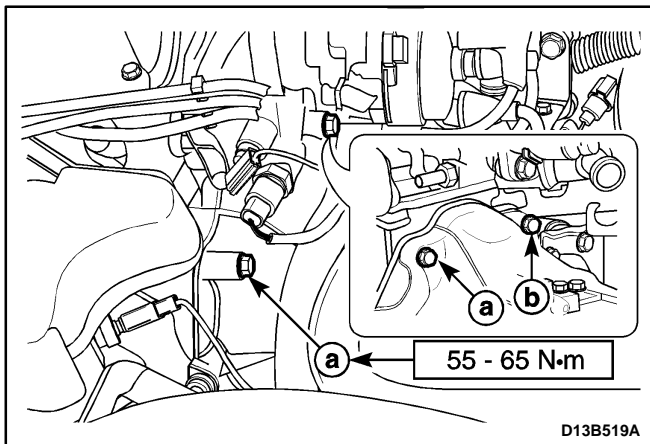

5. Install the transaxle upper bolts.

Tighten

Tighten the bolts to 55–65 N·m (41–48 lb-ft).

- a. Exhaust manifold side bolt.
- b. Thermostat housing side bolt.

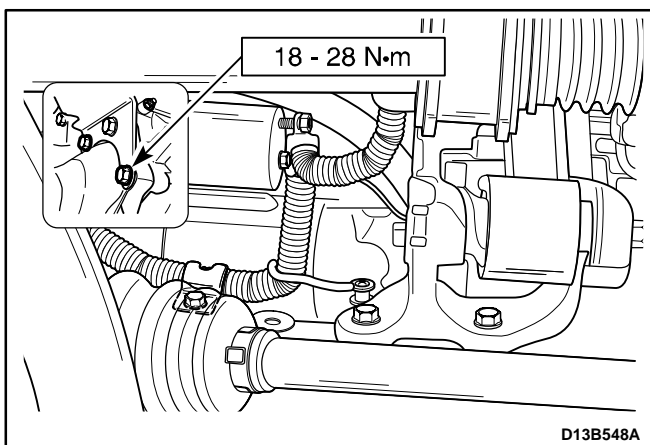

6. Install the starter motor.

Tighten

Tighten the starter motor bolts to 18–28 N·m (13–21 lb-ft).

7. Connect all electric connectors.

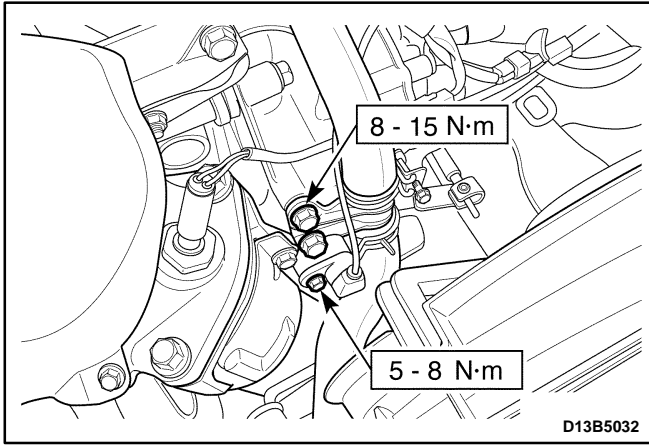

8. Install the radiator lower hose and crank position (CKP) sensor.

Tighten

Tighten the radiator lower hose bolt to 8–15 N·m (70–132 lb-in).

Tighten the CKP sensor bolt to 5–8 N·m (44–70 lb-in).

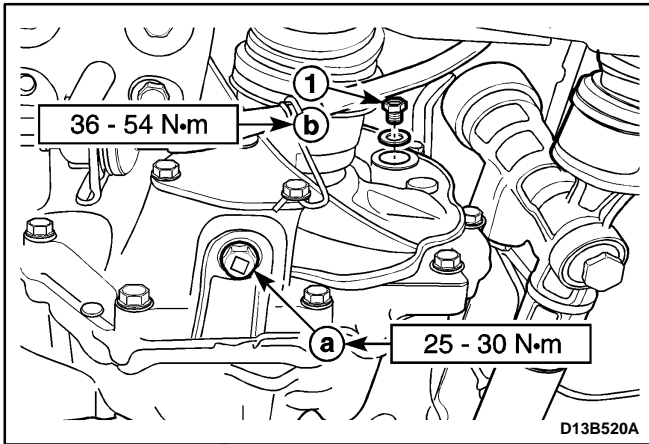

9. Refill the transaxle fluid.

- Tighten the drain plug to 25–30 N·m (18–22 lb-ft) (a).
- Remove the oil level plug (1).
- Refill recommended fluid to the proper level.

Classification	75W – 85 (GL-4)
Capacity	2.1L (2.21 qt)

- Tighten the oil level plug to 36–54 N·m (26–40 lb-ft) (b).

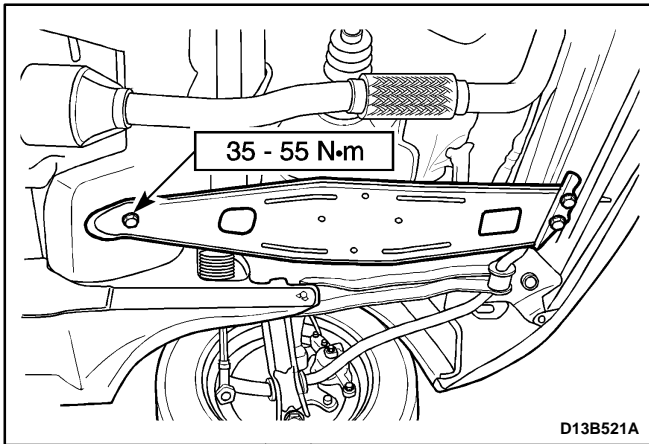

10. Adjust the clutch cable. Refer to *Section 5C, Clutch*.

- Adjust the clutch cable by the clutch cable adjust nut.

11. Install the transaxle under cover.

Tighten

Tighten the transaxle under cover bolts to 35–55 N·m (25–41 lb-ft).

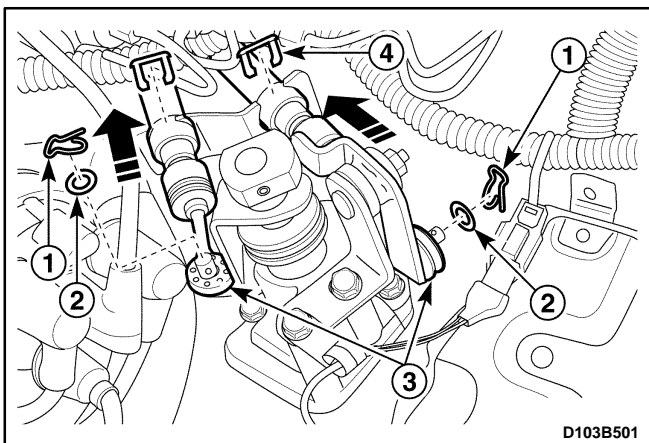

GEAR SHIFT CONTROL CASE ASSEMBLY

Removal Procedure

1. Remove the air hose (air cleaner to throttle body). Refer to *Section 1B, SOHC Engine Mechanical*.
2. Remove the battery.
3. Disconnect the select and the shift control cable.
 - Remove the cable pins (1).
 - Remove the washers (2).
 - Disconnect the select and the shift control cable (3).
 - Remove the cable E-rings (4).
 - Disconnect the cables from the cable bracket.

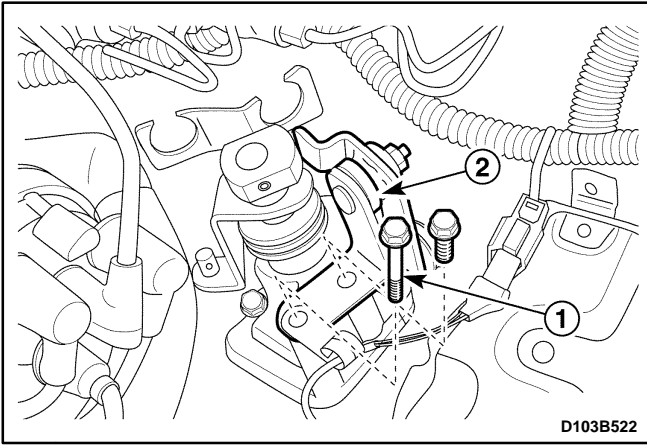

4. Remove the select lever.
 - Remove the bolts (1).
 - Remove the select lever (2).

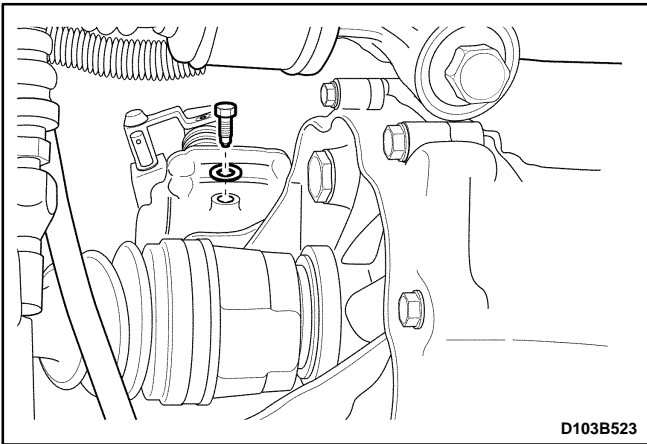

5. Remove the shift interlock bolt.

Important: Certainly remove the shift interlock bolt. Otherwise, the gear shift control case can not be removed.

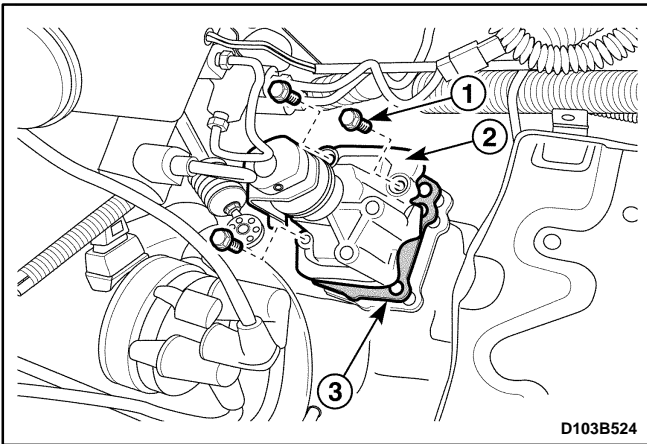

6. Remove the gear shift control case assembly.

- Remove the bolts (1).

Important: Make sure the gear shift lever is in NEUTRAL.

- Remove the gear shift control case assembly (2).
- Remove the gasket (3).

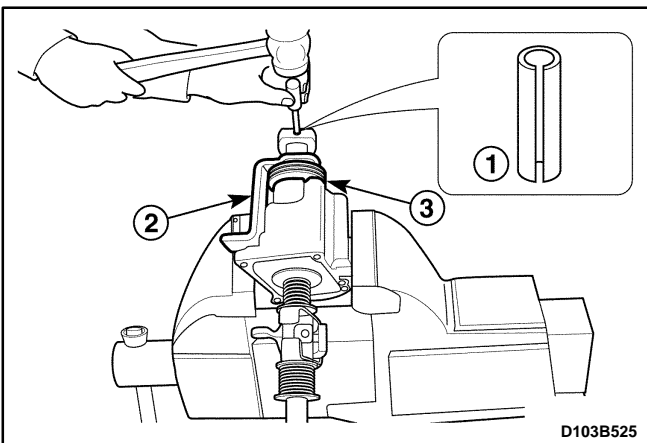

7. Remove the shift lever.

- Position the gear shift control case assembly to the vice with a protector.
- Remove the lever pin with a pin punch and a hammer (1).
- Remove the shift lever (2).
- Remove the boot (3).

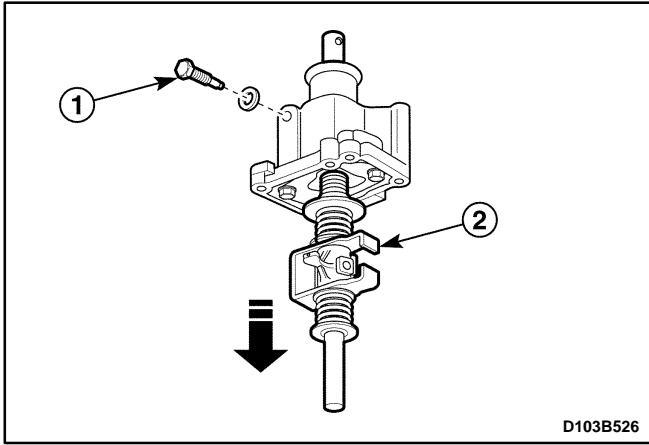

8. Remove the select/shift shaft.
- Remove the shift guide bolt (1).
 - Remove the select/shift shaft (2).

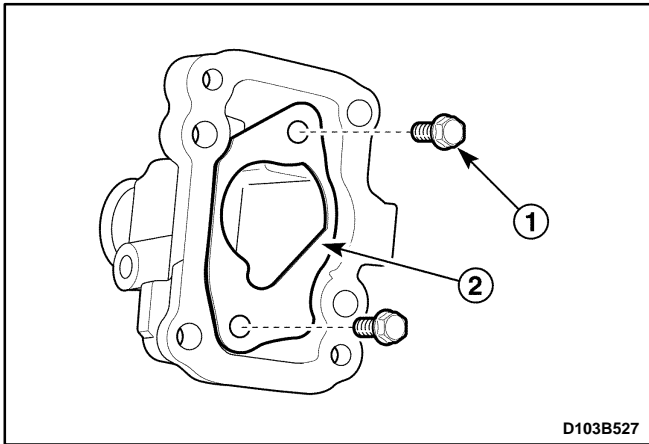

9. Remove the gear shift control case plate.
- Remove the bolts (1).
 - Remove the Plate from the case (2).

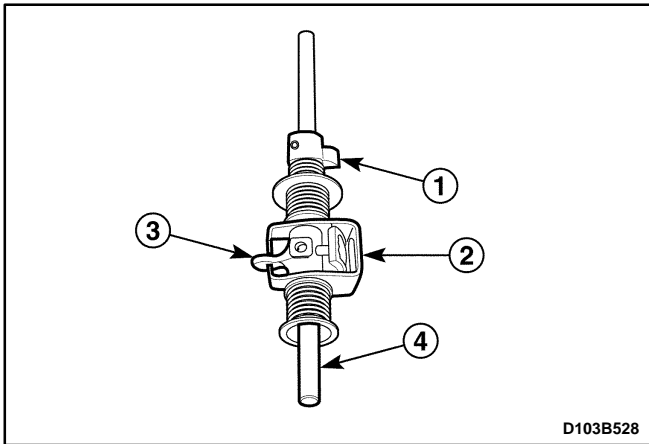

Inspection Procedure

1. Inspect for worn or damaged the fifth/reverse shift cam (1).
2. Inspect for worn or damaged shift interlock plate (2).
3. Inspect for worn or damaged select/shift lever (3).
4. Inspect for bent or damaged select/shift shaft (4).

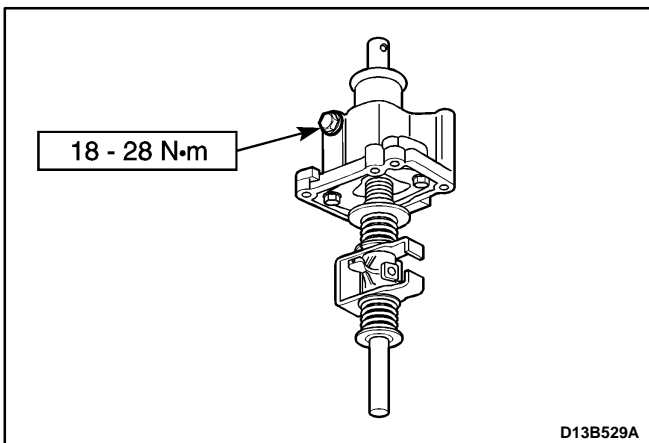

Installation Procedure

1. Install in the reverse order of removal.
2. Install the shift guide bolt.

Tighten

Tighten the shift guide bolt to 18–28 N•m (13–21 lb-ft).

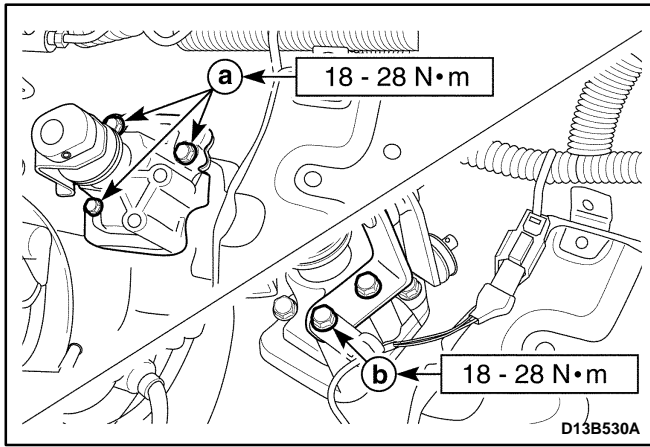

3. Install the gear shift control case and the select lever.

Tighten

- Tighten the gear shift control case bolts to 18–28 N•m (13–21 lb-ft).
 - a. Gear shift control case bolt.
- Tighten the select lever bolts to 18–28 N•m (13–21 lb-ft).
 - b. Select lever bolt.

Important: Make sure a correct bolt. There is length difference between select lever bolts.

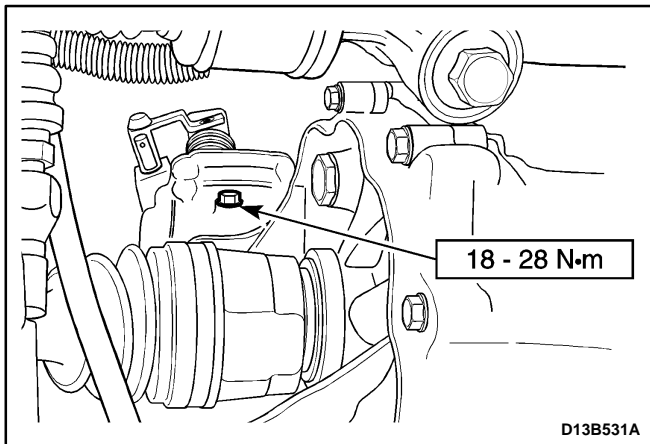

4. Install the shift interlock bolt.

Tighten

Tighten the shift interlock bolt to 18–28 N•m (13–21 lb-ft).

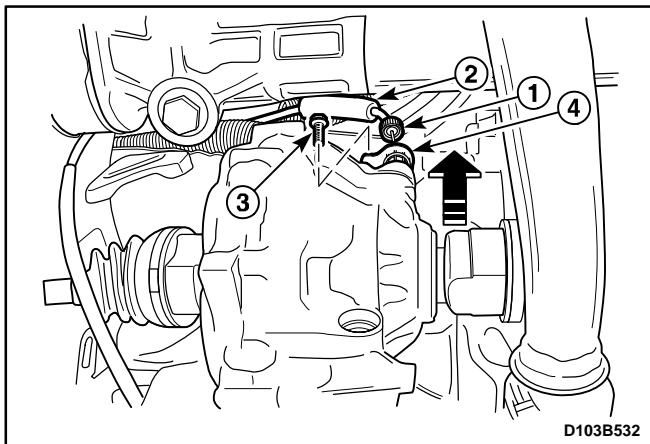

SPEEDOMETER DRIVEN GEAR AND CABLE

(Left-Hand Drive Shown, Right-Hand Drive Similar)

Removal Procedure

1. Remove the speedometer driven gear assembly.
 - Loosen the nut. (1).
 - Disconnect the cable (2).
 - Remove the bolt (3).
 - Remove the speedometer driven gear assembly (4).
- Disconnect the vehicle speed sensor connector (If equipped).
 - a. Vehicle speed sensor connector.
- Disconnect the vehicle speed sensor.
 - b. Vehicle speed sensor.

Caution: Be careful to prevent personal injury while the exhaust pipe is hot.

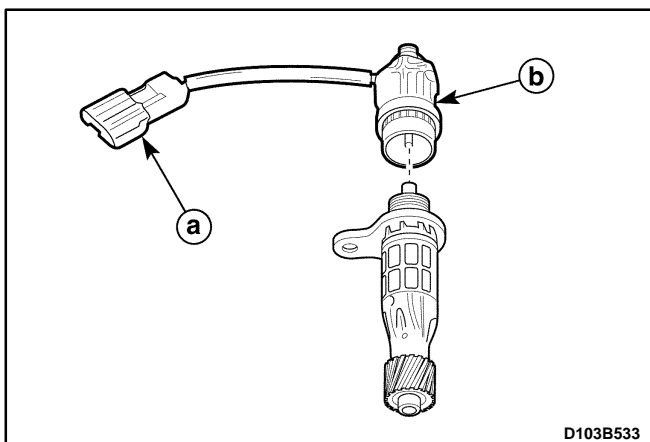

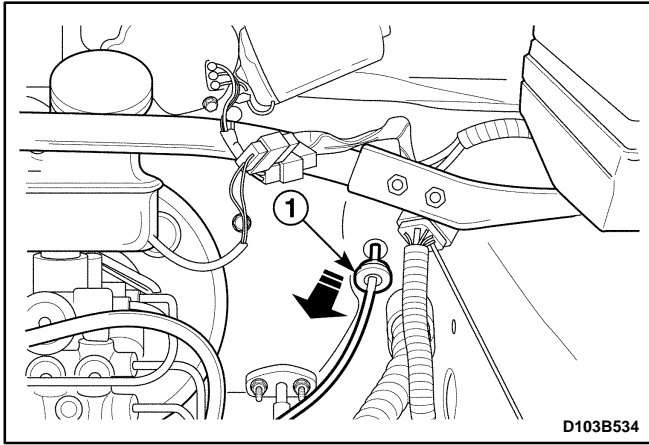

2. Remove the battery. Refer to *Section 1E, Engine Electrical*.
3. Disconnect the instrument cluster side cable. Refer to *Section 9E, Instrumentation/Driver Information*.
4. Remove the speedometer cable.
 - Remove the cable grommet (1).
 - Pull out the speedometer cable from the dash panel.

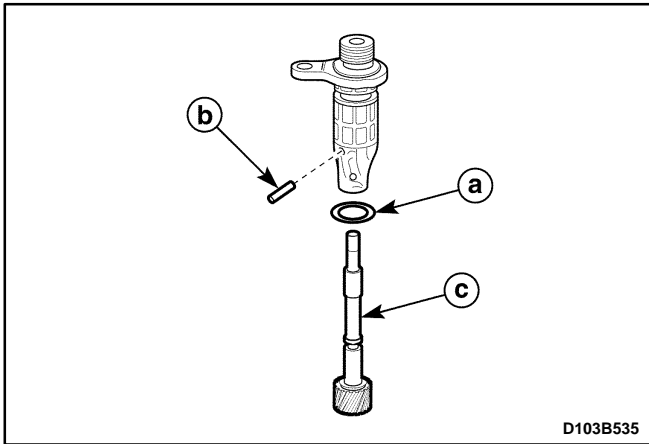

Inspection Procedure

1. Remove the O-ring from the speedometer driven gear housing.
2. Remove the driven gear pin and disconnect the driven gear.
 - Check for a damaged or torn O-ring.
 - Check for a worn or damaged tooth of driven gear.
 - a. O-ring.
 - b. Driven gear pin.
 - c. Driven gear.

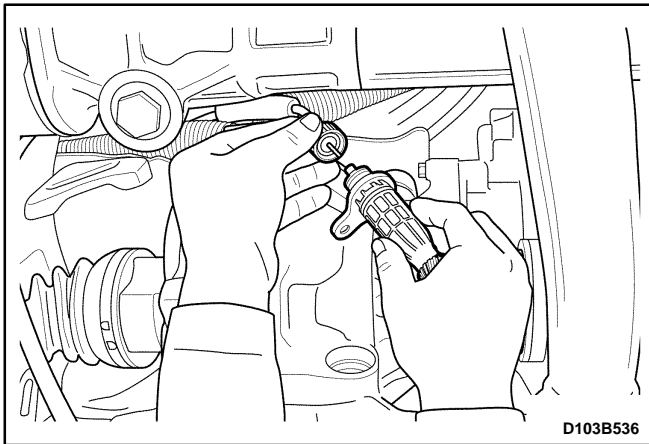

Installation Procedure

1. Install in the reverse order of removal.

Important: Install the speedometer driven gear assembly after connecting the speedometer cable with the speedometer driven gear assembly completely.

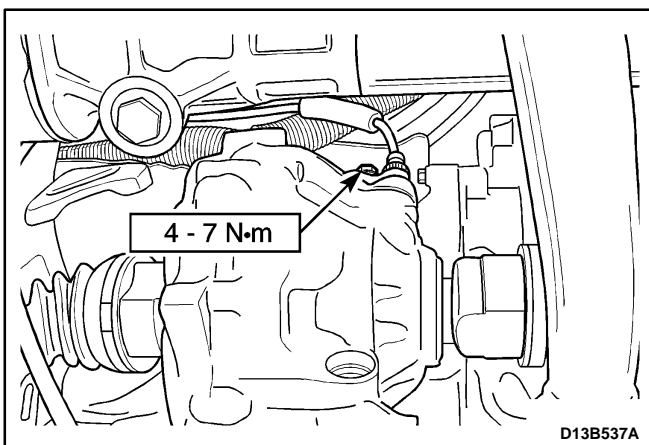

2. Install the speedometer driven gear assembly to transaxle housing.

Tighten

Tighten the speedometer driven gear assembly bolt to 4-7 N•m (35-62 lb-in).

GEAR SHIFT CONTROL CABLE

Removal Procedure

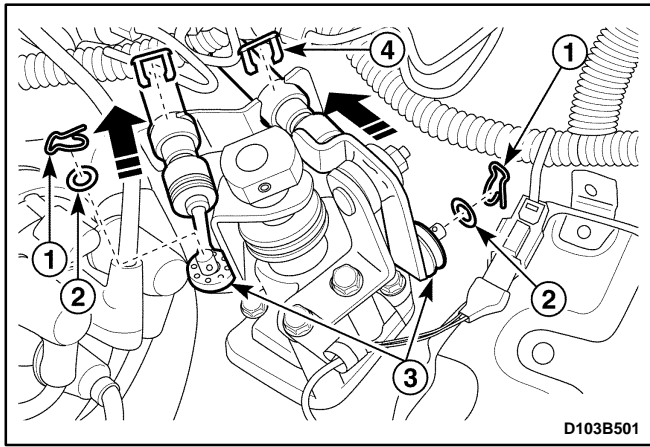

1. Remove the air hose (air cleaner to throttle body). Refer to *Section 1B, SOHC Engine Mechanical*.

2. Remove the battery.

3. Disconnect the transaxle side select and shift control cable.

- Remove the cable pins (1).
- Remove the washers (2).
- Disconnect the select and shift control cable (3).
- Remove the cable E-rings (4).
- Disconnect the cables from the cable bracket.

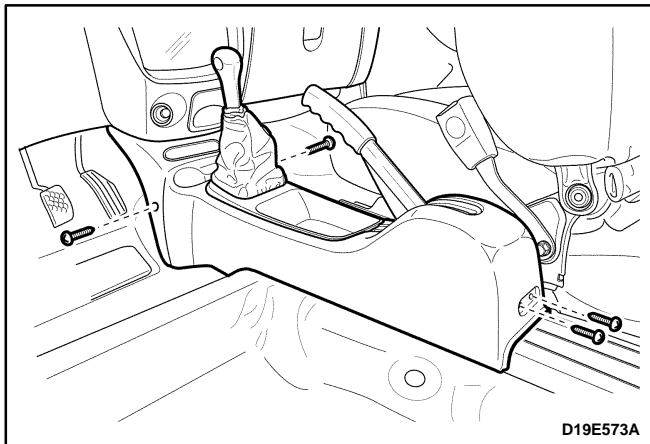

4. Remove the floor console. Refer to *Section 9G, Interior Trim*.

- Put aside the floor carpet in order to get the gear shift cable shown.

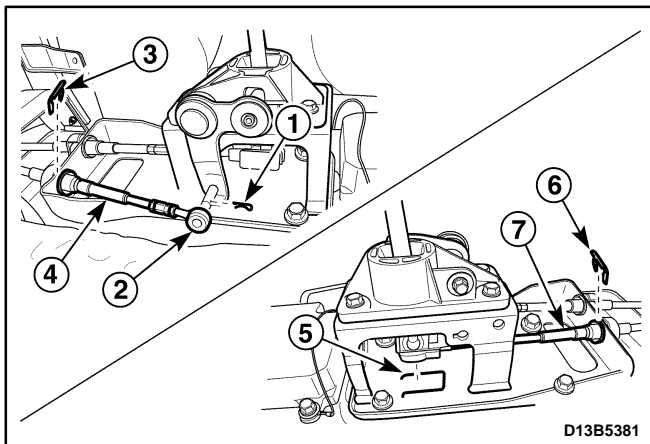

5. Disconnect the gear shift lever side select and shift control cable.

- Remove the select control cable clip (1).
- Ply off the eye ring (2).
- Remove the select control cable E-ring (3).
- Disconnect the select control cable (4).
- Remove the shift control cable pin (5).
- Remove the shift control cable E-ring (6).
- Ply off the shift control cable (7).

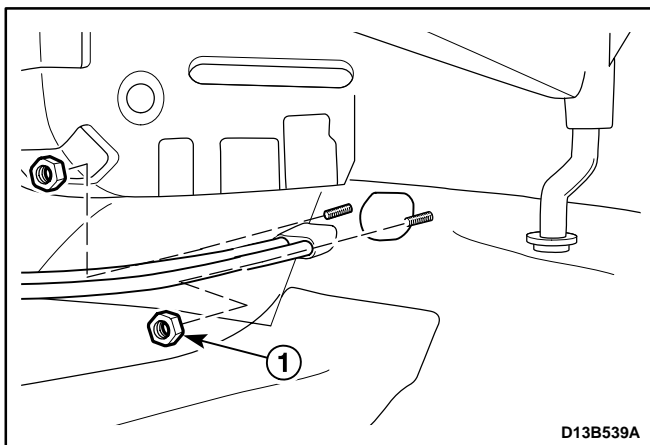

6. Remove the select and shift control cable.

- Remove the nuts (1).
- Pull the cables out in the passenger room.

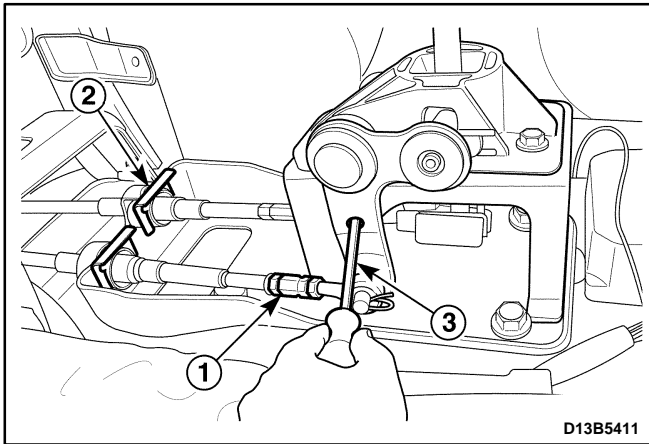
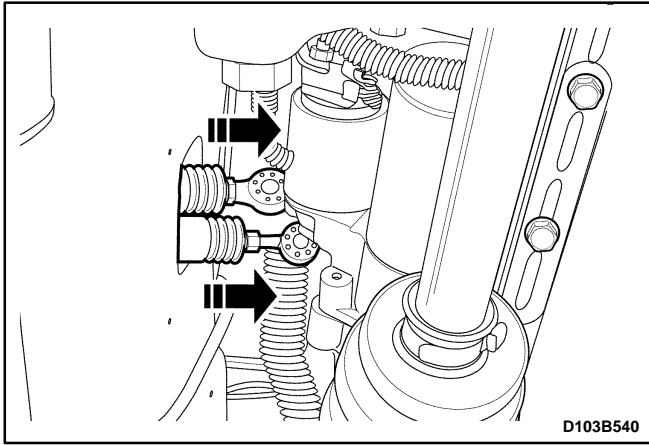

Installation Procedure

1. Install in the reverse order of removal.
2. Push the cables toward the engine compartment through dash panel's hole slightly.
3. Position the cables on the select and the shift lever.

4. Connect the transaxle side select and shift control cable.
5. Connect the gear shift lever side shift control cable.
6. Connect the gear shift lever side select control cable.
 - Insert the select control cable eye ring to the select arm pin (1).
 - Install the selector lever control cable clip (2).
 - Install the select control cable to gear shift lever bracket with E-ring (3).
 - Insert a driver to the select arm adjustment hole to prevent the movement of gear shift lever in NEUTRAL (4).
7. Tighten the adjust nuts.

Tighten

Tighten the select cable adjust nut to 8–12 N•m (71–106 lb-in).

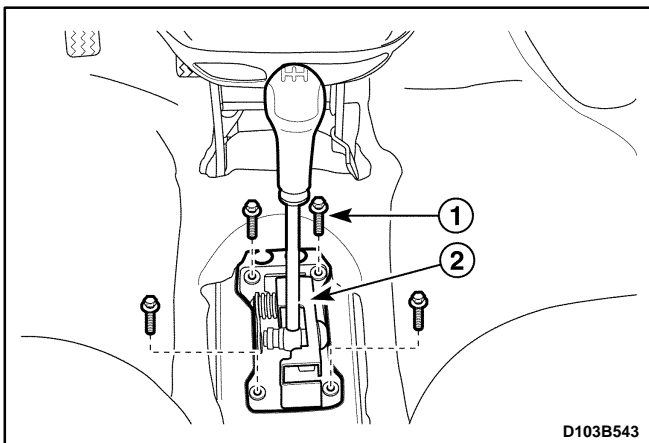

GEAR SHIFT CONTROL LEVER

Removal Procedure

1. Remove the floor console. Refer to *Section 9G, Interior Trim*.
2. Disconnect the select and shift control cable. Refer to "Gear Shift control cable" in this section.
3. Remove the gear shift control lever assembly.
 - Remove the bolts (1).
 - Remove the gear shift control lever assembly (2).
 - Remove the gear shift lever sensor connector. (If equipped with auto clutch).

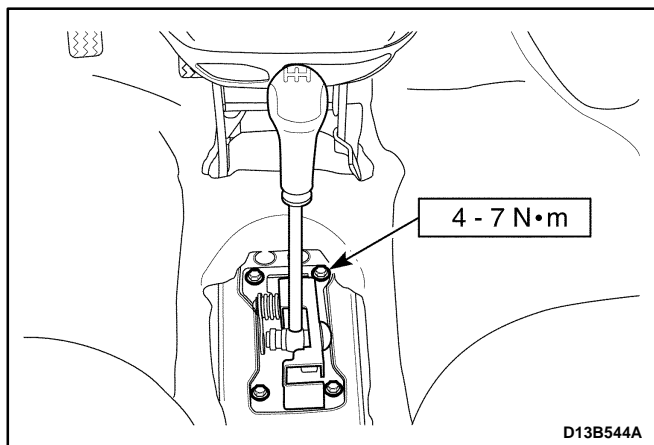

Installation Procedure

1. Install in the reverse order of removal.
2. Install the gear shift control lever assembly.

Tighten

Tighten the bolts to 4–7 N•m (35–62 lb-in).

3. Adjust the select cables. Refer to "Gear Shift Control Cable" in this section.

MAINTENANCE AND REPAIR

UNIT REPAIR

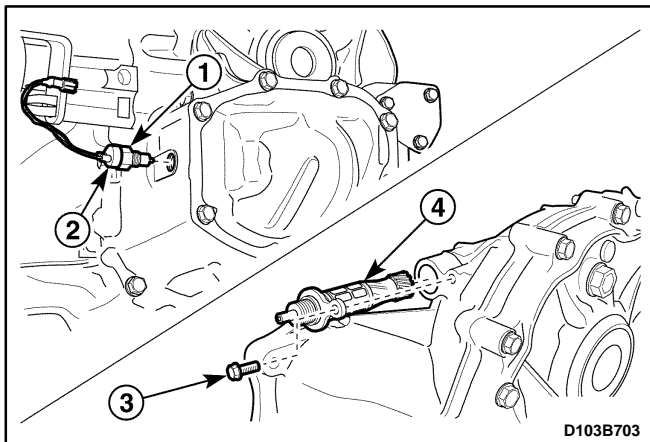
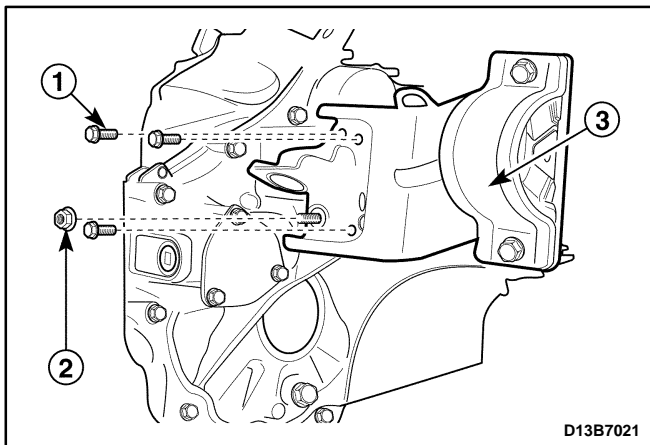
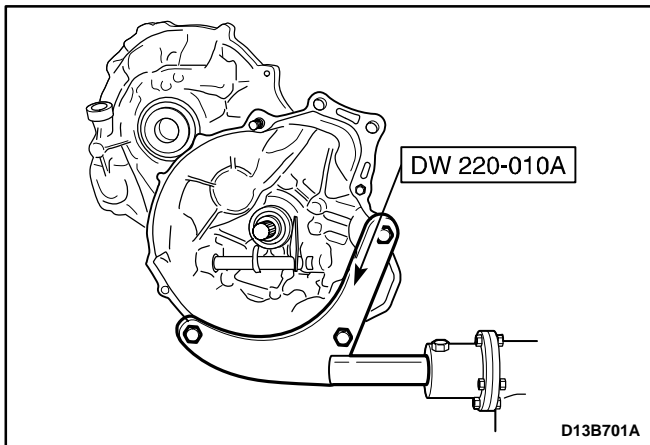

GEAR UNIT

Tools Required

09913-76010	Bushing, Seal Installer
DW09940-53111	Gear, Bearing Installer
DW09943-78210	Bushing, Seal Installer
DW220-010A	Transaxle Fixture
KM519	Oil Seal Installer

Disassembly Procedure

1. Remove the manual transaxle. Refer to "Manual Transaxle Assembly" in this section.
2. Position the manual transaxle to a transaxle stand using the transaxle fixture DW220-010.
3. Remove the related clutch parts. Refer to *Section 5C, Clutch*.
4. Remove the manual transaxle mounting bracket.
 - Remove the bolts (1).
 - Remove the nut (2).
 - Remove the mounting bracket (3).
5. Disconnect the backup light switch and speedometer driven gear assembly.
 - Remove the nut (1).
 - Disconnect the backup light switch (2).
 - Remove the bolt (3).
 - Remove the speedometer driven gear assembly (4).

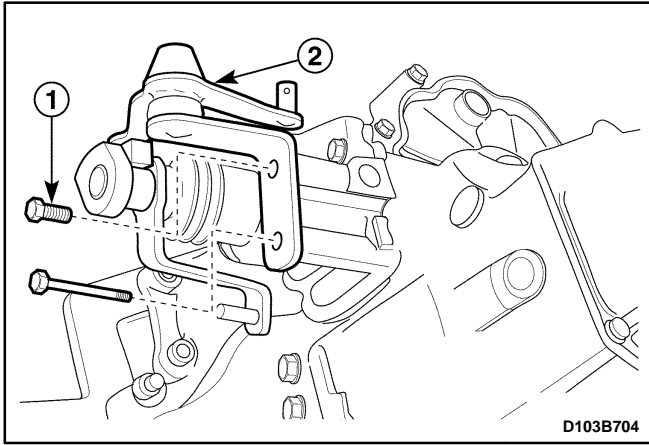

6. Remove the select lever.
- Remove the bolt (1).
 - Remove the select lever (2).

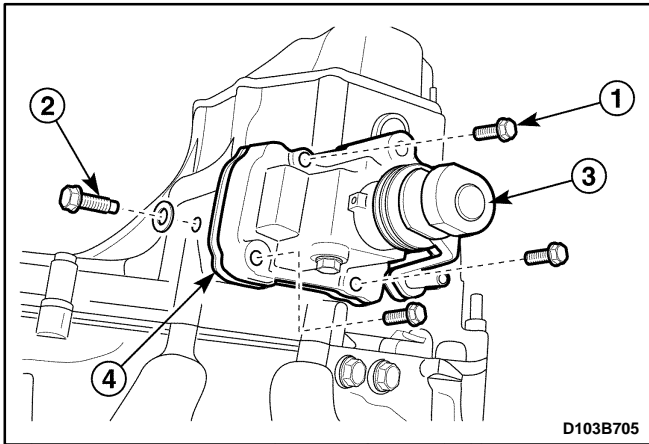

7. Remove the gear shift control case assembly.
- Remove the bolts (1).
 - Remove the shift interlock bolt (2).

Important: Certainly remove the shift interlock bolt. Otherwise, gear shift control case can not be removed.

- Remove the gear shift control case assembly (3).
- Remove the gasket (4).

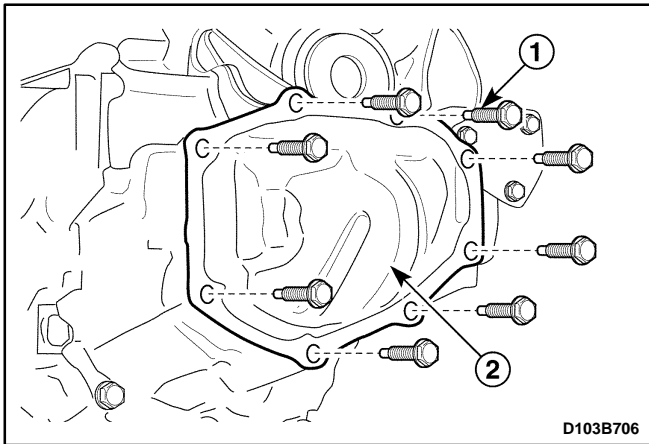

8. Remove the side cover.

- Remove the bolts (1).
- Remove the side cover using a rubber hammer (2).
- Remove the sealant on the side cover and the transaxle case.

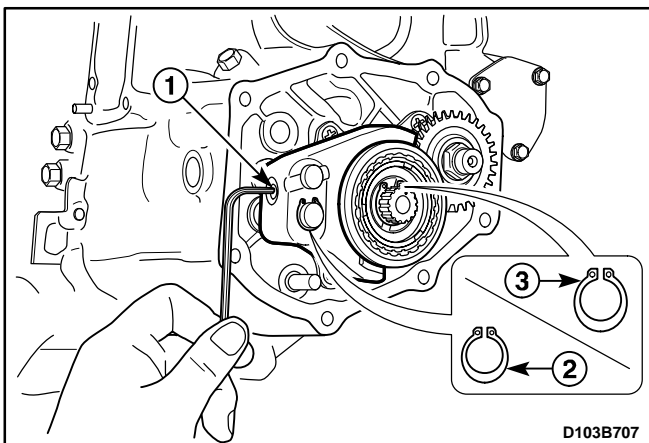

9. Remove the fifth-gear shift fork guide ball, the snap ring and the input shaft fifth-gear snap ring.

- Remove the fifth-gear shift fork plug (1).
- Remove the guide ball using a magnet.
- Remove the fifth-gear shift fork snap ring (2).
- Remove the fifth-gear snap ring (3).
- Remove the fifth-gear synchronizer plate.

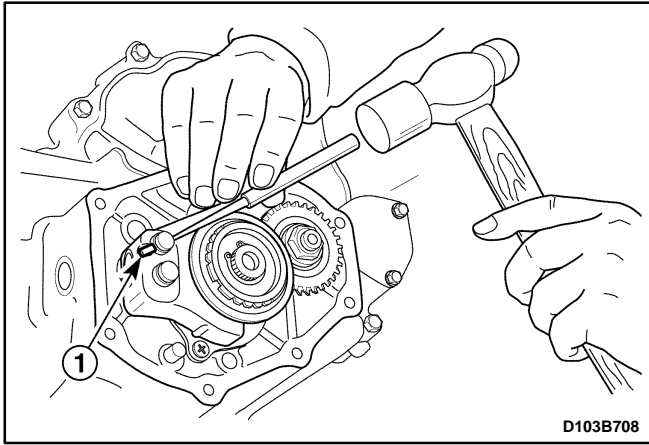

10. Remove the fifth-gear shift fork pin.
 - Shift the shift fork to the fifth-gear.
 - Remove the fork pin using a pin punch and a hammer (1).

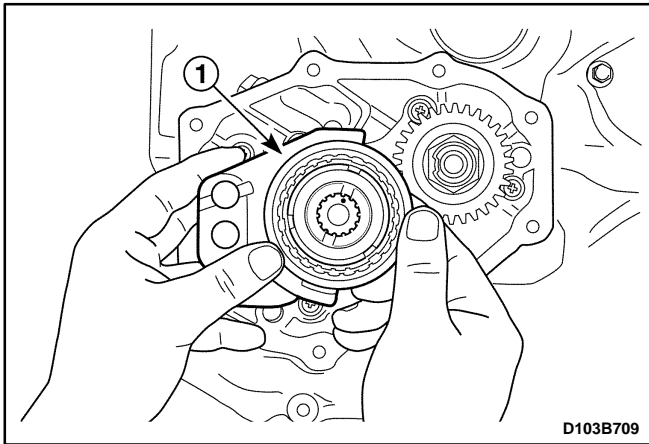

11. Remove the input shaft fifth-gear fork and synchronizer hub assembly.
 - Pull and remove the fork and the hub assembly together (1).
 - Remove the sleeve, key and spring from the synchronizer hub assembly.

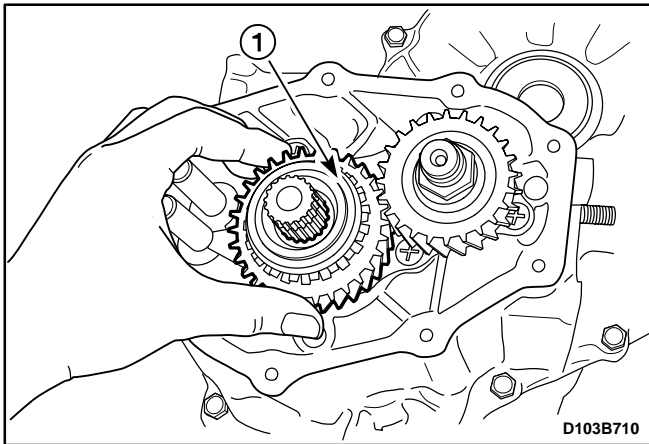

12. Remove the input shaft fifth-gear, the synchronizer ring and the fifth-gear bearing.
 - Pull and remove the fifth-gear, wave spring and synchronizer ring together (1).
 - Remove the fifth-gear bearing.

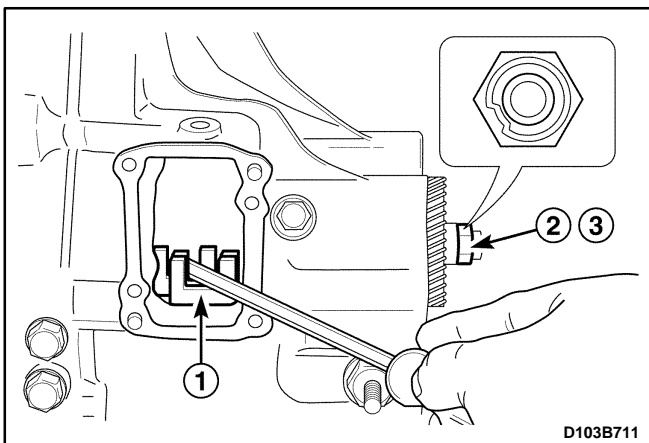

13. Remove the countershaft fifth-gear.
 - Shift the shift yoke using a driver to engage the first-gear and the third-gear or the second-gear and the fourth-gear (1).
 - Remove the caulking and the nut. (2, 3)

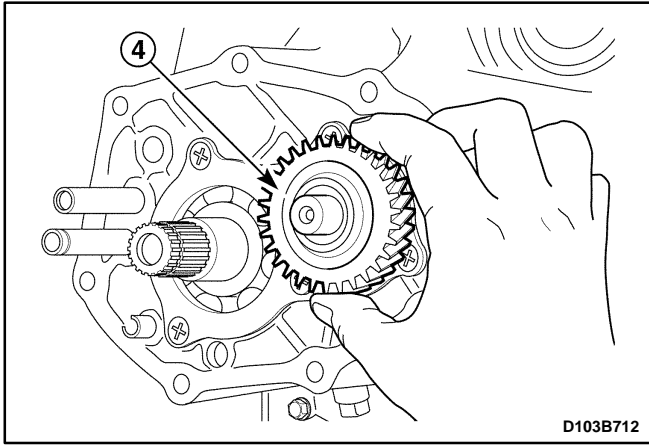

- Remove the counter shaft fifth-gear (4).

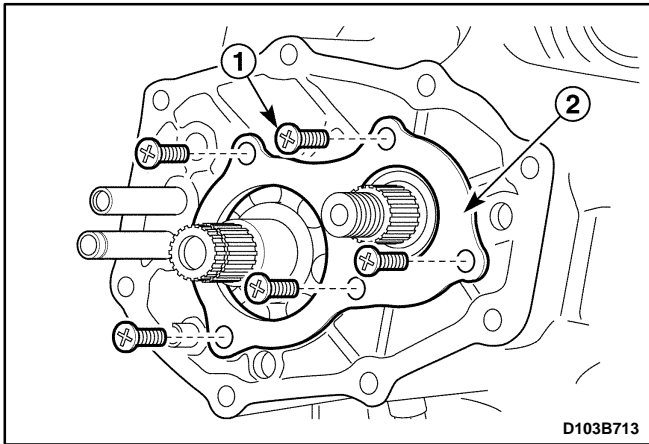

14. Remove the side cover plate and the counter shaft bearing shim.
- Remove the screws (1).
 - Remove the side cover plate (2).
 - Remove the counter shaft bearing shim.

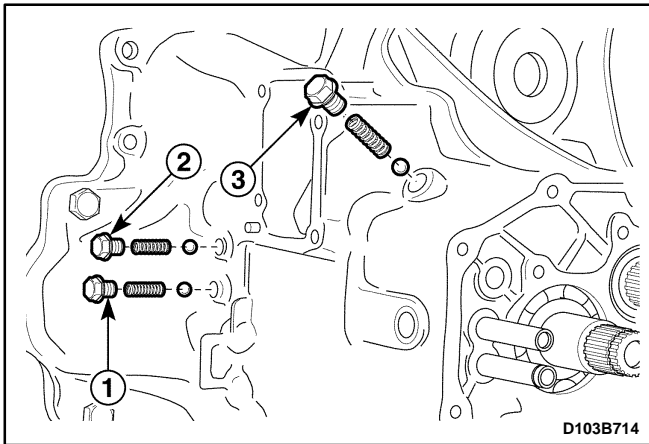

15. Remove the shift shaft spring and ball.
- Remove the bolt and remove the fifth-reverse gear shift shaft spring and ball (1).
 - Remove the bolt and remove the third-fourth gear shift shaft spring and ball (2).
 - Remove the bolt and remove the first-second gear shift shaft spring and ball (3).

Important: There is difference between the fifth-reverse gear shift shaft spring and the others. Mark it to distinguish easily when installing.

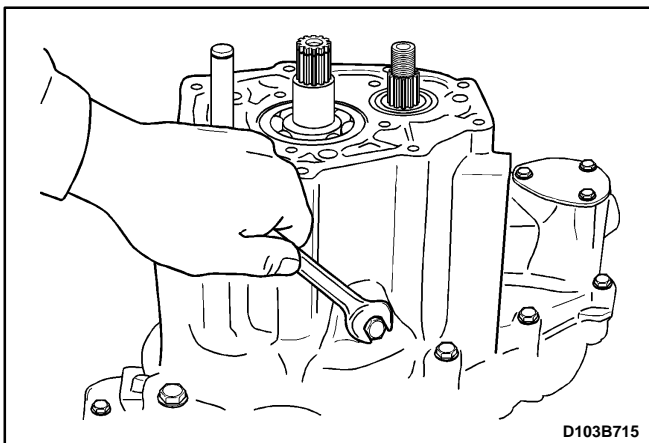

16. Remove the reverse idle gear shaft bolt.

Important: The case (Left) can not be removed without removing the reverse idle gear shaft bolt.

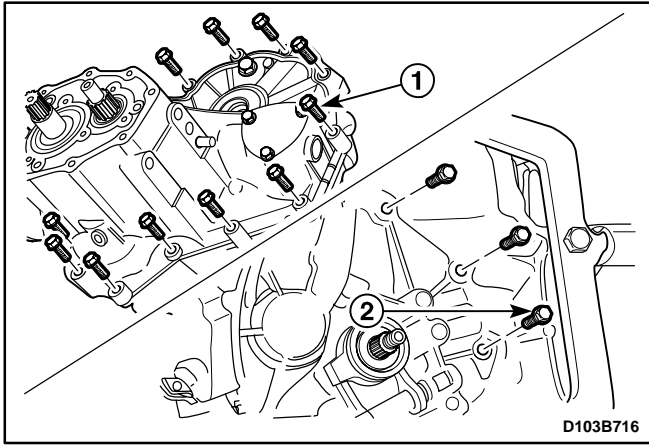

17. Remove the transaxle case (Left).
 - Remove the bolts from the left side case (1).
 - Remove the bolts, stud bolts if equipped with auto clutch.
 - Remove the bolts from the right side of case (2).
 - Remove the left side case by hitting with a rubber hammer lightly.
 - Remove the sealant on the case.

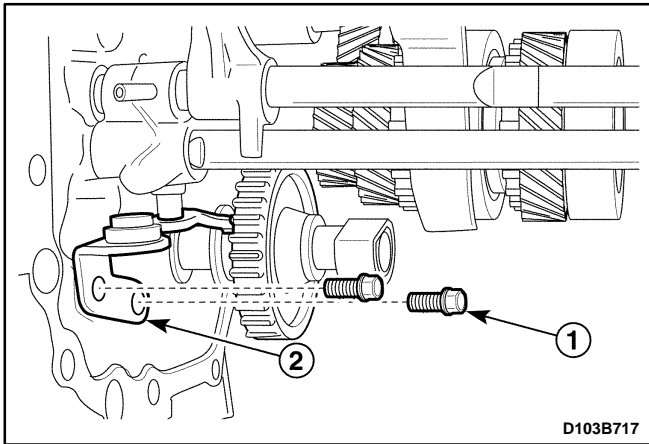

18. Remove the reverse gear shift lever.
 - Remove the bolts (1).
 - Remove the reverse gear shift lever (2).

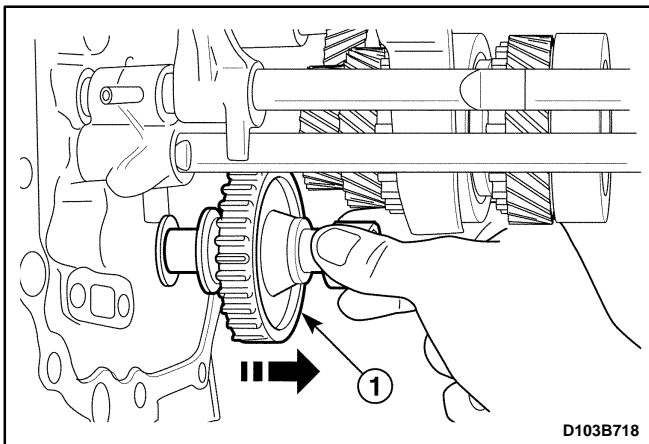

19. Remove the reverse idle gear shaft assembly.
 - Push the reverse idle gear toward inner case.
 - Pulling shaft and remove the reverse idle gear and shaft (1).
 - Remove the reverse idle gear from the shaft.

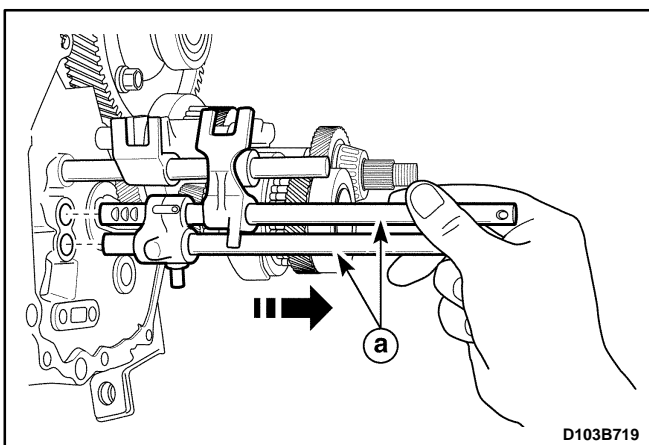

20. Remove the fifth-reverse gear shift shaft.
 - a. Fifth-reverse gear shift shaft.

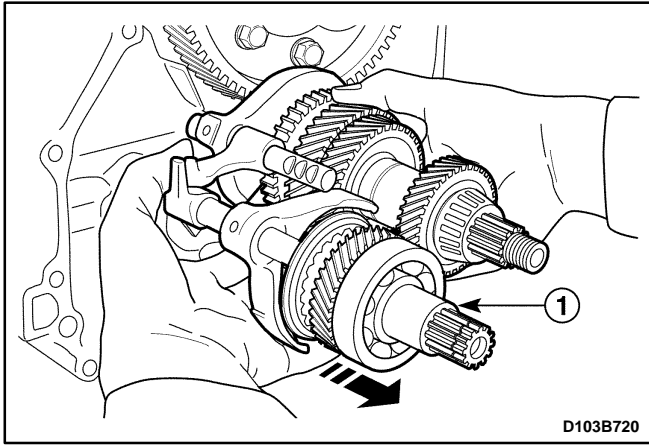

21. Remove the gear unit.

- Remove the gear unit and the shift shaft assembly together (1).

Notice: Be careful not to damage teeth of the counter shaft pinion and the differential ring gear.

- Remove the high and the low speed shift shaft assembly from the gear unit.

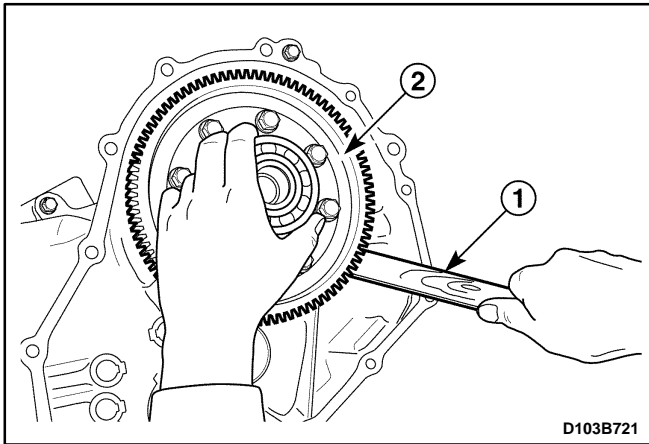

22. Remove the differential assembly.

- Insert a wooden stick into the lower side of differential (1).
- Remove the differential assembly by moving it right and left (2).

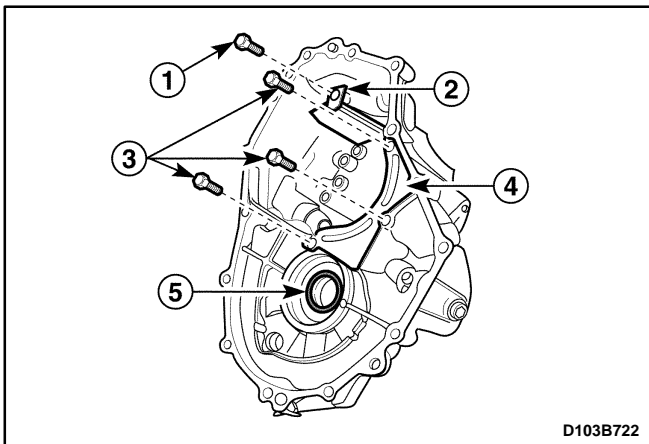

23. Remove the related parts of the transaxle case (Left Side).

- Remove the bolt (1).
- Remove the oil gutter (2).
- Remove the bolts (3).
- Remove the oil plate (4).
- Remove the differential left side oil seal using a hammer and a copper chisel (5).

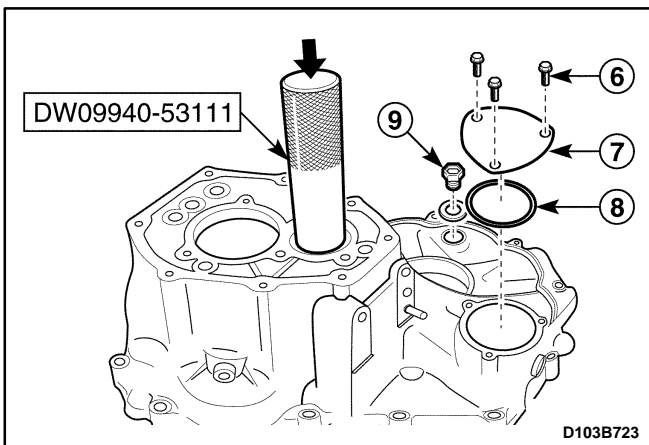

- Remove the bolts (6).
- Remove the case cap (Left Side) (7).
- Remove the case cap O-ring (Left Side) (8).
- Remove the oil level plug (including steel gasket) (9).
- Remove the counter shaft bearing outer race using a hammer and the gear, bearing installer DW 09940-53111.

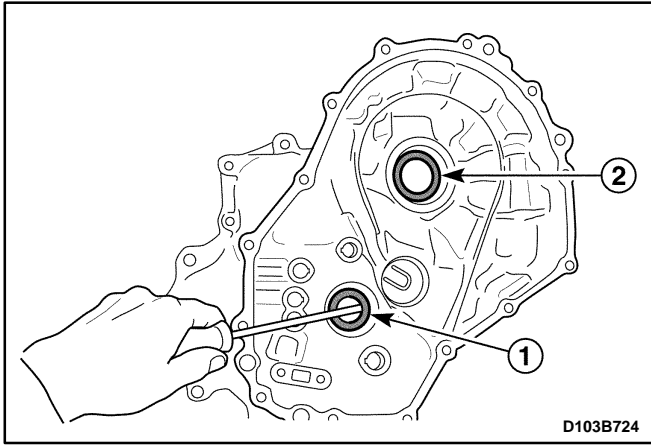

24. Remove the related parts of the transaxle case (Right Side).

- Remove the input shaft oil seal using a screwdriver (1).
- Remove the differential left side oil seal using a hammer and a copper chisel (2).

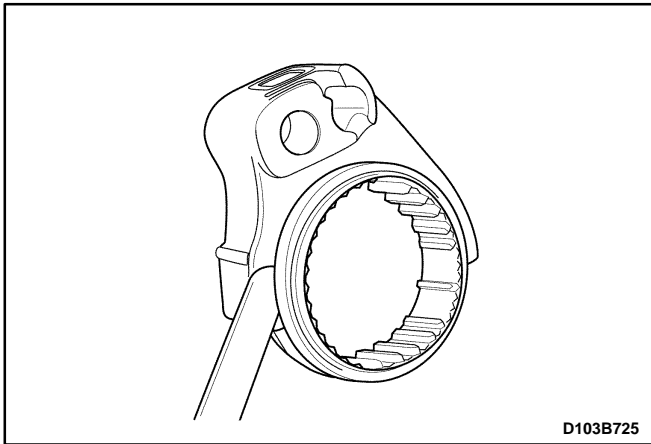

Synchronizer Sleeve and Shift Fork Inspection

1. Measure the clearance between synchronizer sleeve and shift fork and if the clearance exceeds the limit, replace the shift fork.

Unit : mm (in.)

Clearance Between Sleeve and Shift Fork	Standard	Limit
	0.2 ~0.6 (0.008~0.024)	1.0 (0.039)

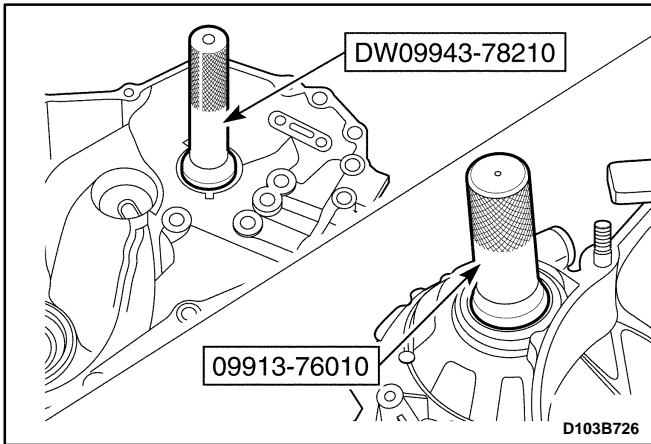

Assembly Procedure

1. Install the related parts of the transaxle case (Right Side).

- Install the input shaft oil seal using the bushing seal installer DW09943-78210.
- Install the differential right side oil seal using the bushing, seal installer 09913-76010.

Important: Use only a new oil seal.

Important: Coat the transaxle inner parts with gear fluid when installing.

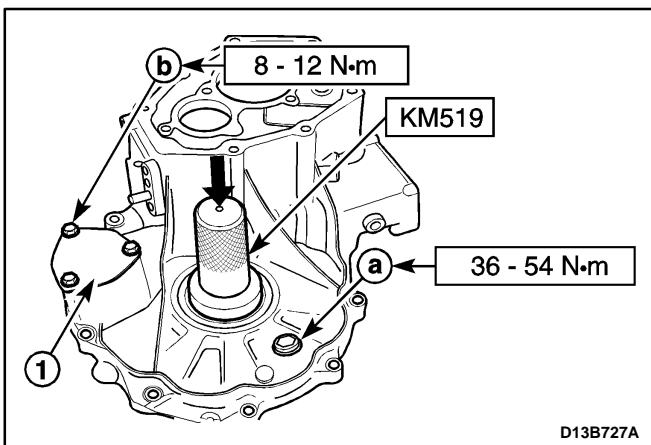

2. Install the related parts of the transaxle case (Left Side).

- Install the oil plate with the bolts.
- Install the oil gutter with the bolt.
- Install the oil level plug (including steel gasket).
 - a. Oil level plug.

Tighten

Tighten the oil level plug to 36-54 N·m (26-40 lb-ft).

- Install the left side case cap with the bolts (including O-ring) (1).

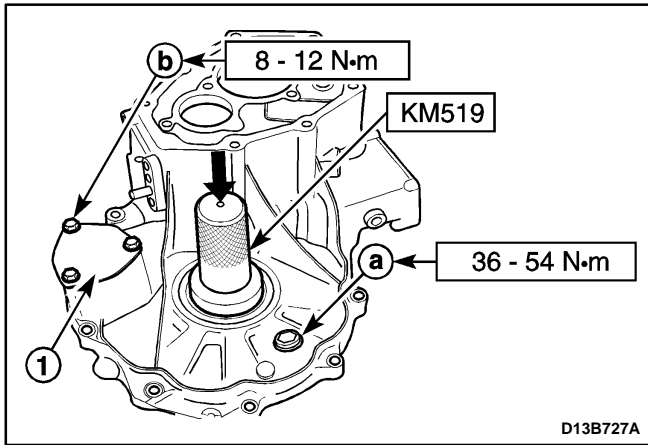

Tighten

Tighten the bolt to 8–12 N·m (71–106 lb-in).

b. Case cap retaining bolt.

- Install the differential left side oil seal using the oil seal installer KM519.

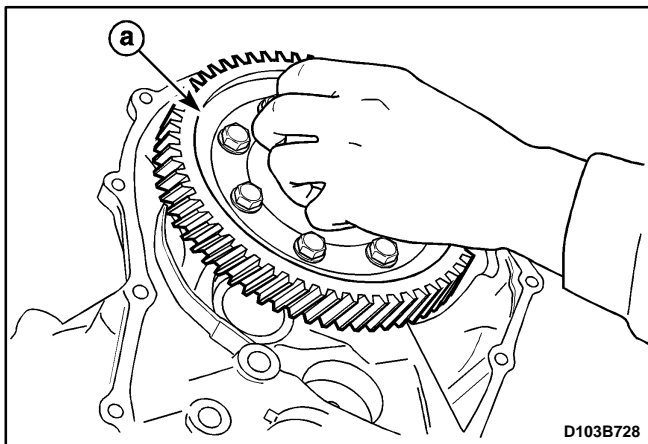

3. Install the differential assembly to the right side of transaxle case.

a. Differential assembly.

- When the differential ring gear surface is lower than the right side of transaxle case surface, it is installed correctly.

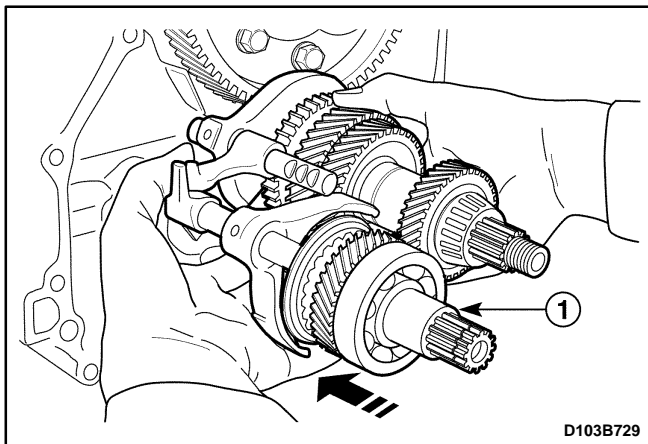

4. Install the low and the high speed shift shaft assembly to the gear unit.

5. Install the gear unit.

- Push the gear unit by matching it with the input and the counter shaft hole (1).

Notice: Be careful not to damage teeth of the counter shaft pinion and the differential ring gear.

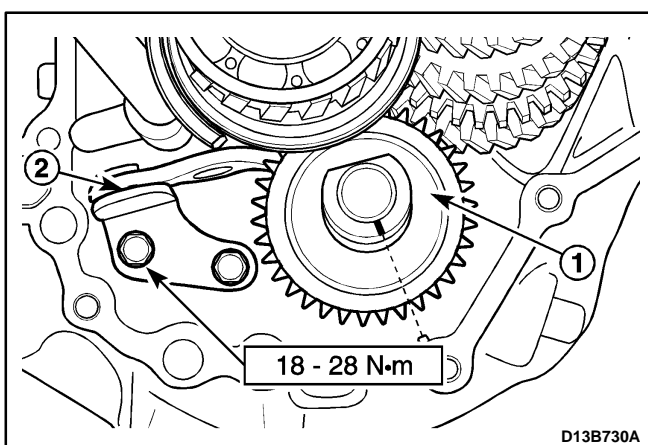

6. Install the fifth–reverse gear shift shaft.

7. Install the reverse idle gear shaft assembly and the reverse gear shift lever.

- Install the reverse idle gear shaft assembly (1).

Important: Match the marking of the reverse idle gear shaft bolt hole with the protrusion of the transaxle case (Right Side).

- Install the reverse gear shift lever (2).

Tighten

Tighten the bolts to 18–28 N·m (13–21 lb-ft).

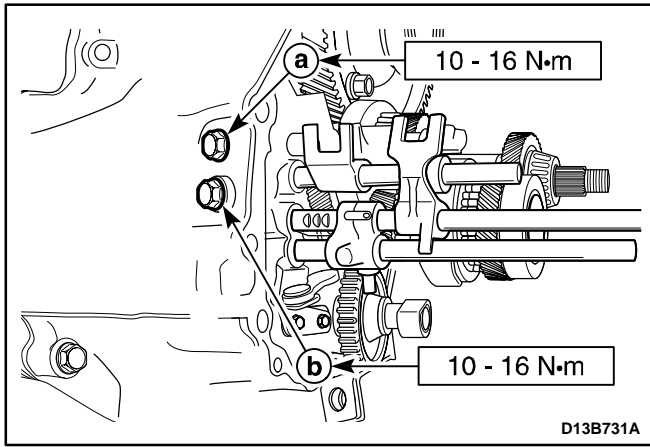

8. Install the shift shaft ball and spring.

- Install the third–fourth gear shift shaft ball and spring.

Tighten

Tighten the bolt to 10–16 N·m (7–12 lb-ft) (a).

- Install the fifth–reverse gear shift shaft ball and spring.

Tighten

Tighten the bolt to 10–16 N·m (7–12 lb-ft) (b).

Important: Install the fifth–reverse gear shift shaft spring marked when removing.

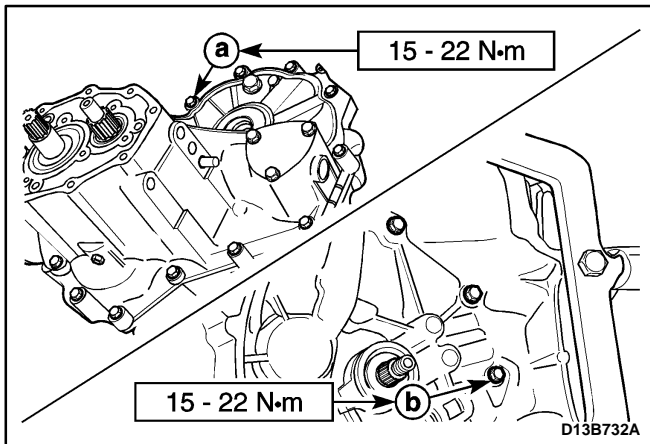

9. Install the transaxle left side case.

- Coat the transaxle case with recommended sealant.

Transaxle Case Sealant	THREE BOND 1215
------------------------	-----------------

- Install the transaxle left side case to the transaxle right side case.

Tighten

Tighten the bolts to 15–22 N·m (11–16 lb-ft) (a).

- Tighten the bolts (8), stud bolts (3) if equipped with auto clutch.

Tighten the bolts to 15–22 N·m (11–16 lb-ft) (b).

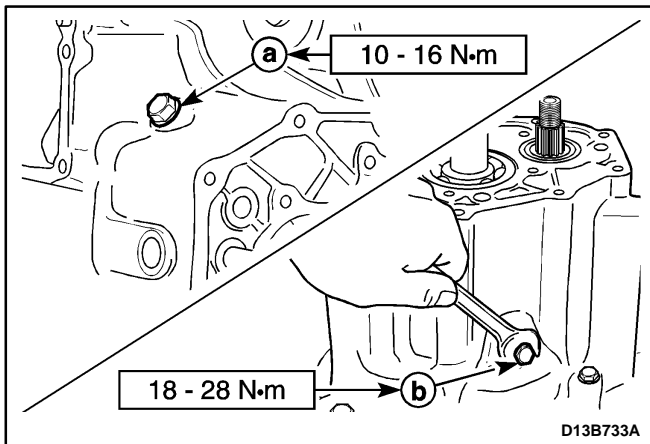

10. Install the first–second gear shift shaft ball and spring.

Tighten

Tighten the bolt to 10–16 N·m (7–12 lb-ft) (a).

11. Install the reverse idle gear shaft bolt.

Tighten

Tighten the bolt to 18–28 N·m (13–21 lb-ft) (b).

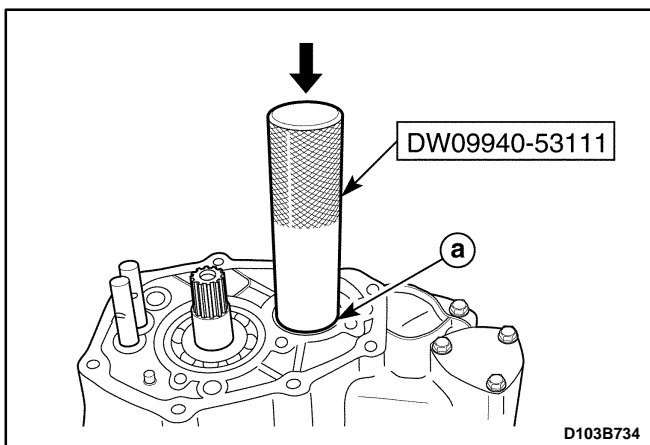

12. Install the counter shaft bearing outer race.

- Install the counter shaft bearing outer race using the gear, bearing installer DW09940–53111.

a. Bearing outer race.

Important: Check if the bearing and the outer race are correctly installed by rotating counter shaft.

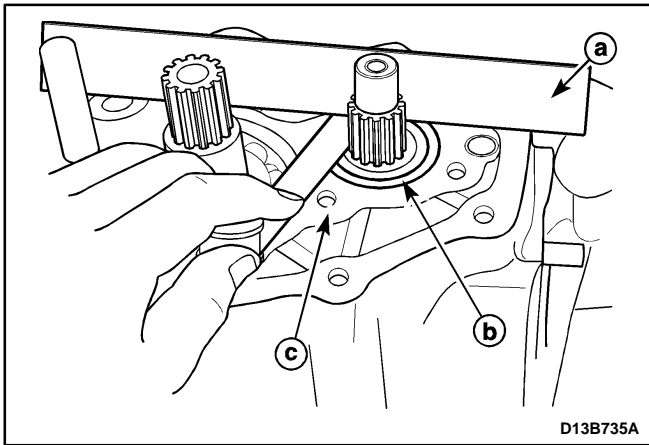

13. Install the counter shaft bearing shim.

- Measure clearance between the transaxle case surface and the bearing outer race using a straight ruler and gauge.
- Select shim in order that clearance is within standard.

Unit : mm (in.)

Measured value (A)	Shim thickness
0.33 – 0.37 (0.0130 – 0.0146)	0.45 (0.0177)
0.38 – 0.42 (0.0147 – 0.0165)	0.50 (0.0197)
0.43 – 0.47 (0.0169 – 0.0185)	0.55 (0.0217)
0.48 – 0.52 (0.0189 – 0.0205)	0.60 (0.0236)
0.53 – 0.57 (0.0209 – 0.0224)	0.65 (0.0256)
0.58 – 0.62 (0.0228 – 0.0244)	0.70 (0.0276)
0.63 – 0.67 (0.0248 – 0.0264)	0.75 (0.0295)
0.68 – 0.72 (0.0268 – 0.0283)	0.80 (0.0315)
0.73 – 0.77 (0.0287 – 0.0303)	0.85 (0.0335)
0.78 – 0.82 (0.0307 – 0.0323)	0.90 (0.0354)
0.83 – 0.87 (0.0327 – 0.0343)	0.95 (0.0374)
0.88 – 0.92 (0.0346 – 0.0362)	1.00 (0.0394)
0.93 – 0.97 (0.0366 – 0.0382)	1.05 (0.0413)
0.98 – 1.02 (0.0386 – 0.0402)	1.10 (0.0433)
1.03 – 1.07 (0.0406 – 0.0421)	1.15 (0.0453)

- a. Straight ruler
- b. Bearing outer race
- c. Case surface

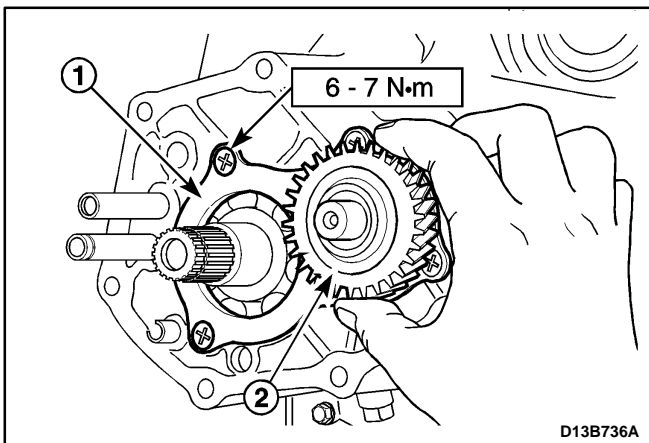

14. Install the side cover plate and the counter shaft fifth gear.

- Install the side cover plate (1).

Tighten

Tighten the screws to 6-7 N.m (53-62 lb-in).

Important: Use only new screws.

- Install the counter shaft fifth gear (2).

Important: Position the machined boss side toward the side cover plate.

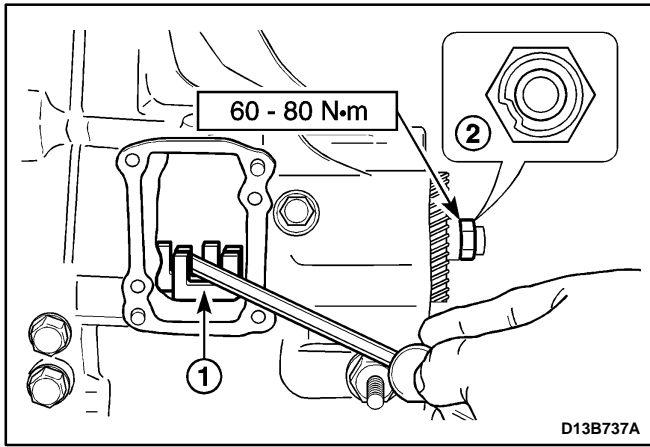

15. Install the counter shaft fifth gear nut.
- Shift the shift yoke using a screwdriver to engage the first-gear and the third-gear or the second-gear and the fourth-gear (1).

Tighten

- Tighten the fifth gear nut to 60-80 N·m (44-59 lb-ft).
- Caulk the nut using a chisel and a hammer (2).

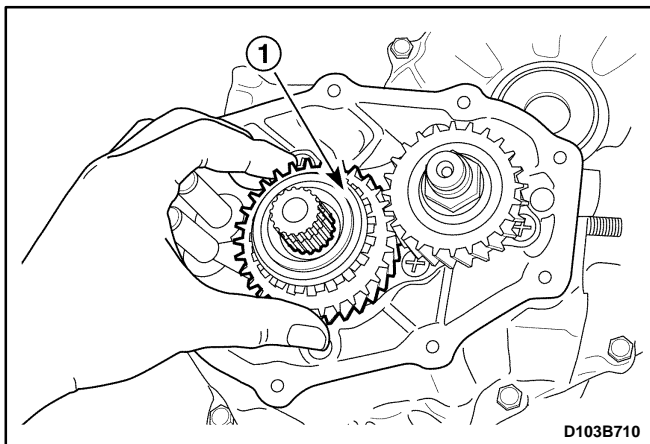

16. Install the input shaft fifth gear bearing and the fifth gear / synchronizer ring.
- Insert the bearing into the input shaft.
 - Install the fifth gear, wave spring and synchronizer ring matching synchronizer's oil groove and input shaft punched mark (1).

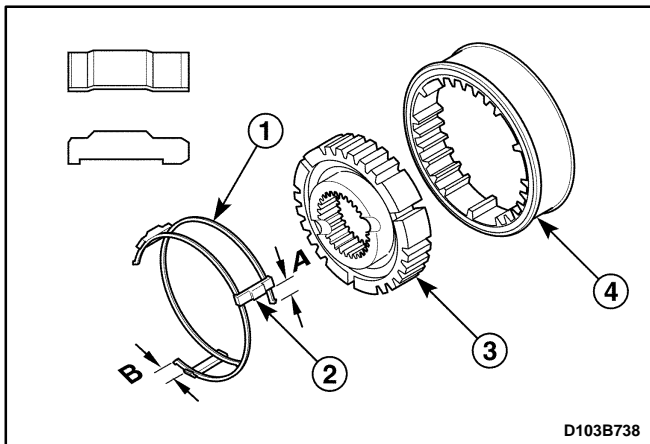

17. Install the fifth gear synchronizer hub assembly.
- Install the synchronizer springs to hub (1).
 - Install the synchronizer key (2).
- Important:** In case of assembling synchronizer sleeve and hub, let A=B.
- Position the longer boss side of hub toward inner side (3).
 - Position the chamfered spline of sleeve toward inner side and install the hub to the sleeve (4).

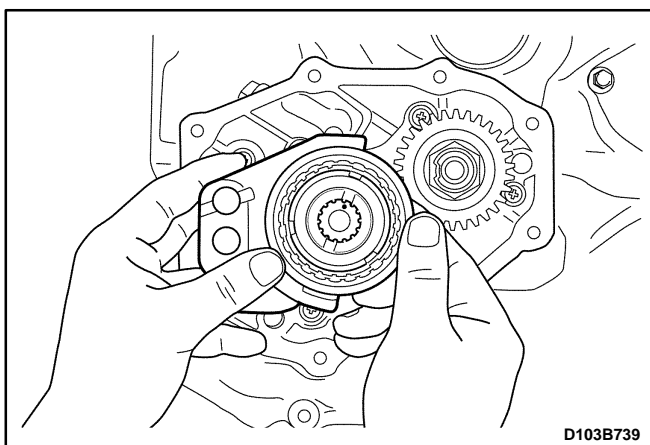

18. Install the fifth gear fork to the synchronizer hub assembly.
19. Install the fifth gear fork and the synchronizer hub assembly to the input shaft.

Important: Position the longer boss side of hub toward inner side and match the synchronizer key and the hub groove with the input shaft punched mark.

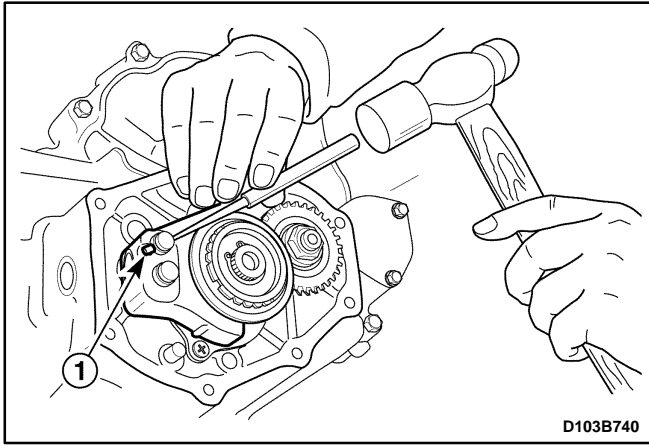

20. Install the fifth gear shift fork pin.
- Push the shift fork toward the fifth gear.
 - Install the shift fork pin using a pin punch and a hammer(1).

Important: Use only new shift fork pin.

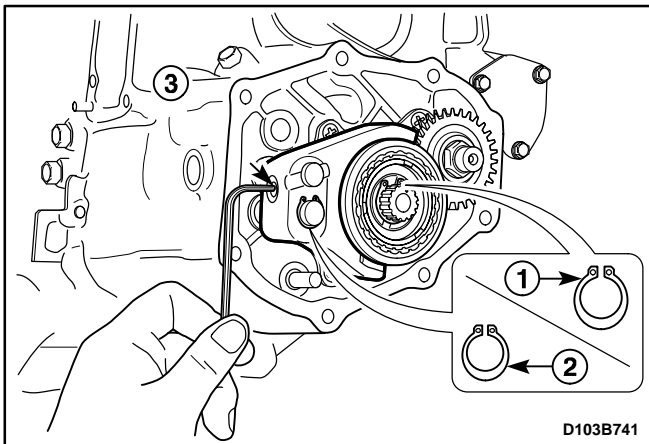

21. Install the input shaft fifth gear snap ring, the fifth gear shift fork snap ring and guide ball.
- Install the fifth gear synchronizer plate.
 - Install the fifth gear snap ring (1).
 - Install the fork snap ring (2).

Important: Use only new snap ring.

- Tighten the fork plug after inserting the guide ball into the fork hole.

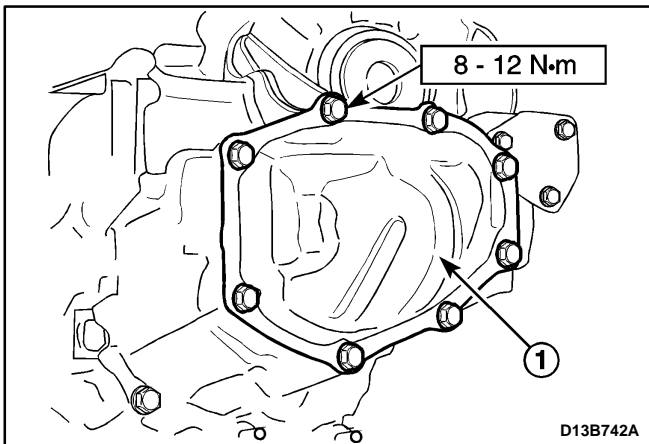

22. Install the side cover(1).

- Coat the side cover with recommended sealant.

Side Cover Sealant

THREE BOND 1215

Tighten

Tighten the side cover bolts to 8–12 N•m (71–106 lb-in).

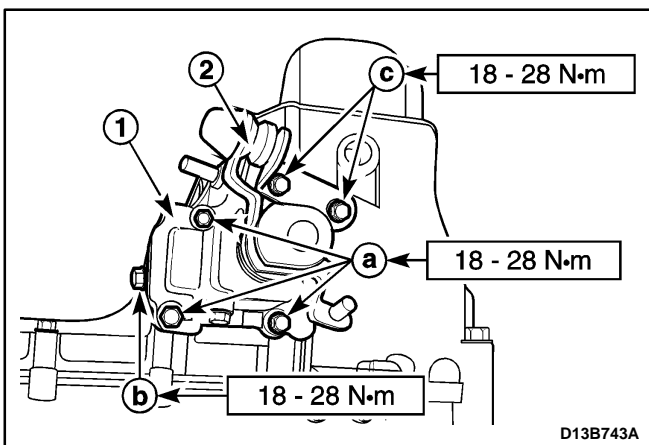

23. Install the gear shift control case assembly.

- Install the case gasket.
- Install the gear shift control case.

Tighten

- Tighten the bolts to 18–28 N•m (13–21 lb-ft) (a).
- Tighten the shift interlock bolt to 18–28 N•m (13–21 lb-ft) (b).
- Install the select lever.

Tighten

Tighten the bolts to 18–28 N•m (13–21 lb-ft) (c).

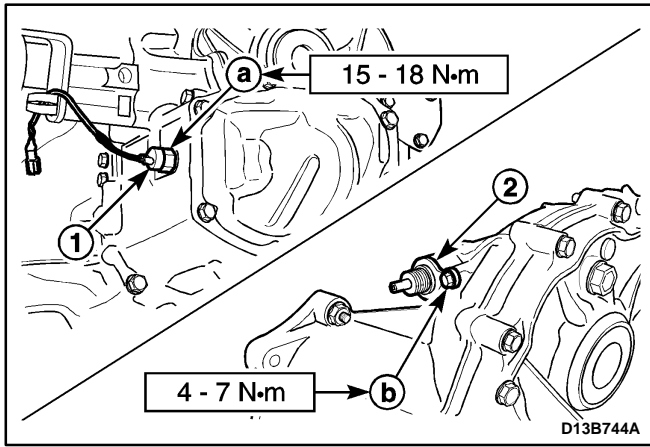

24. Install the backup light switch and the speedometer driven gear assembly.

- Install the backup light switch (1).

Tighten

Tighten the nut to 15–18 N•m (11–13 lb-ft) (a).

- Install the speedometer driven gear assembly (2).

Tighten

Tighten the bolt to 4–7 N•m (35–62 lb-in) (b).

- Install the hydraulic pump assembly (If equipped with auto clutch). Refer to *Section 5D, Auto Clutch*.

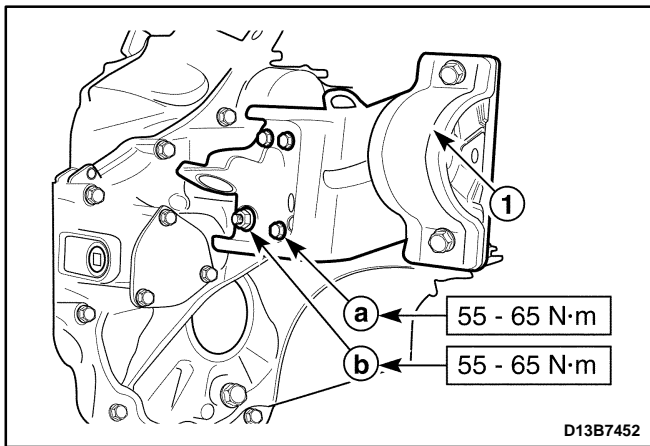

25. Install the transaxle mount.

- Install the mount (1).

Tighten

- Tighten the bolts to 55–65 N•m (41–48 lb-ft) (a).

- Tighten the nut to 55–65 N•m (41–48 lb-ft) (b).

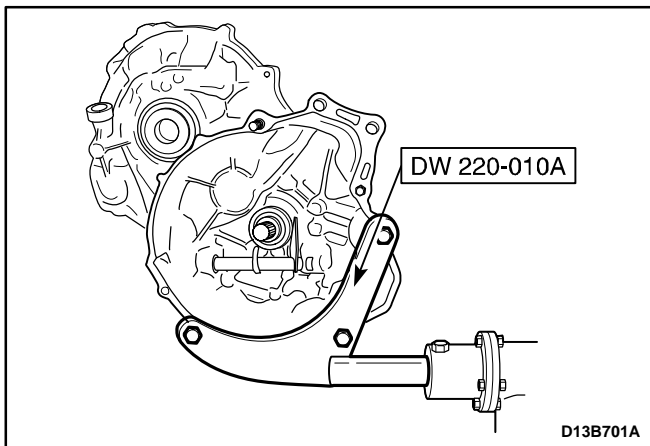

26. Install the related clutch parts. Refer to *Section 5C, Clutch*.

27. Remove the transaxle assembly from transaxle stand.

- Remove the transaxle assembly using the transaxle fixture DW220–010A.

28. Install the transaxle assembly. Refer to “Manual Transaxle Assembly” in this section.

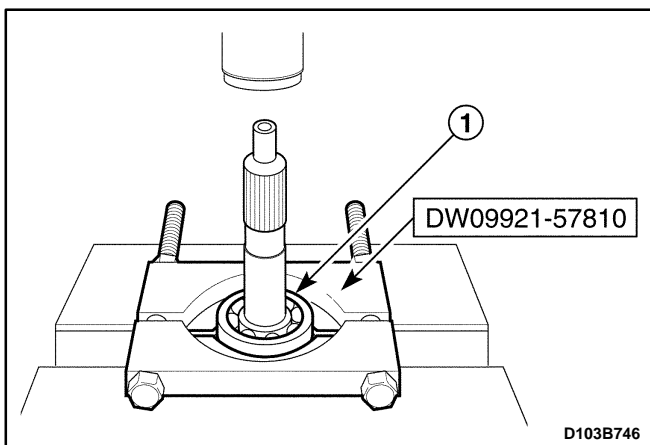

INPUT SHAFT

Tools Required

DW09921–57810 Gear, Bearing Remover

DW09925–98221 Gear, Bearing Installer

DW09940–53111 Gear, Bearing Installer

Disassembly Procedure

1. Remove the gear unit. Refer to “Gear Unit” in this section.

2. Remove the input shaft right side bearing.

- Position the bearing to the gear, bearing remover DW09921–57810.

- Remove the bearing by pressing (1).

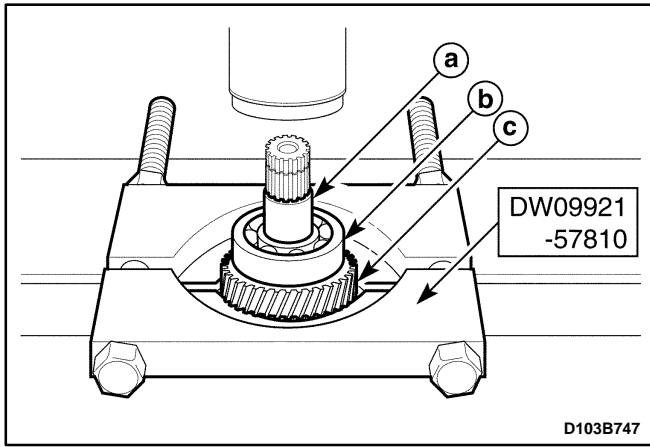

3. Remove the input shaft fifth gear spacer, the left side bearing and the fourth gear.
 - Position the fourth gear to the gear, bearing remover DW09921-57810.
 - Remove the following parts.
 - a. Fifth gear spacer.
 - b. Left side bearing.
 - c. Fourth gear

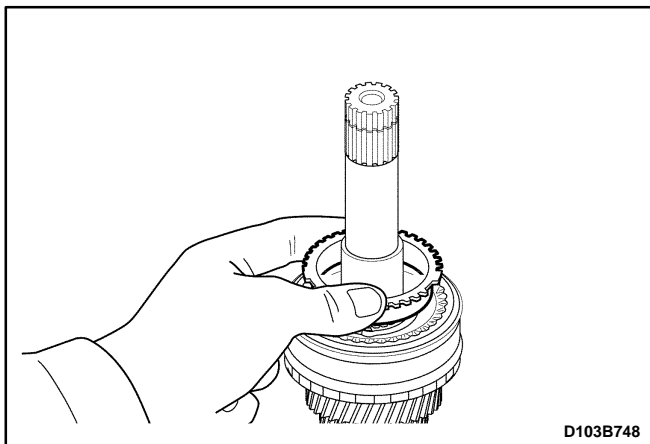

4. Remove the fourth gear bearing.
5. Remove the fourth gear synchronizer ring and wave spring.

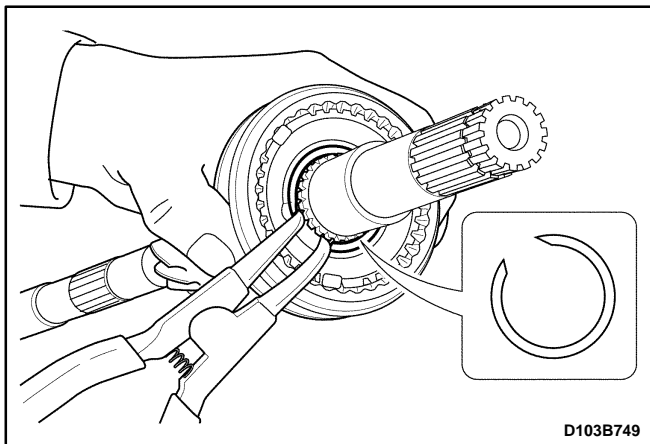

6. Remove the third-fourth synchronizer circlip.

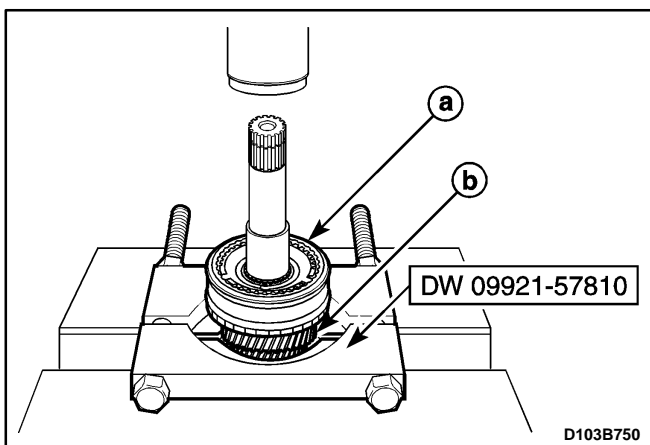

7. Remove the third-fourth synchronizer hub assembly, the third gear 1 synchronizer ring.
 - Position the third gear to the gear, bearing remover DW09921-57810.
 - Remove the following parts.
 - a. Third-fourth synchronizer hub assembly.
 - b. Third gear and synchronizer ring.

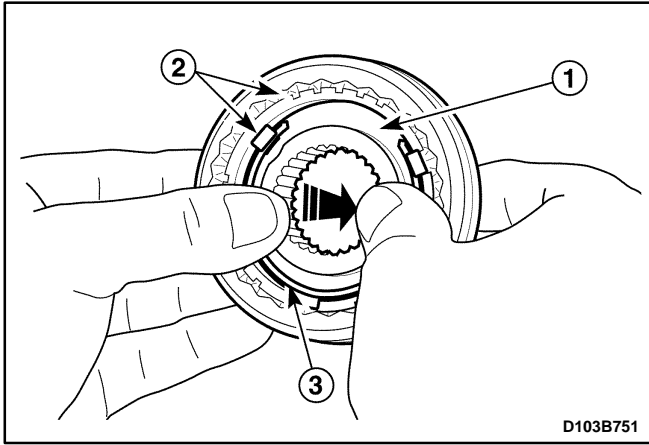

8. Disassemble the third-fourth synchronizer hub assembly.

- Remove the hub (1).
- Remove the synchronizer sleeve and the key (2).
- Remove the synchronizer springs (3).

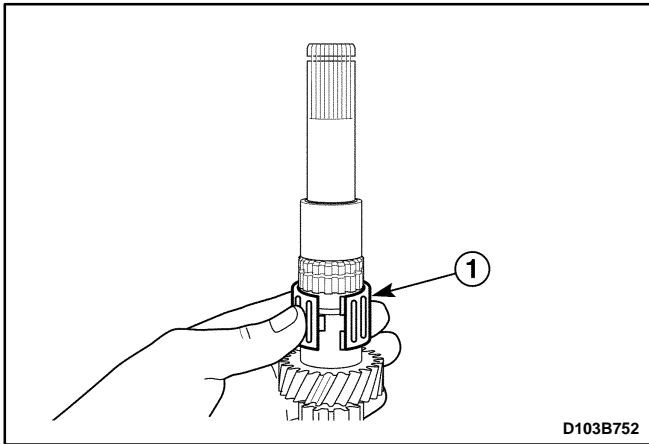

9. Remove the input shaft third gear bearing (1).

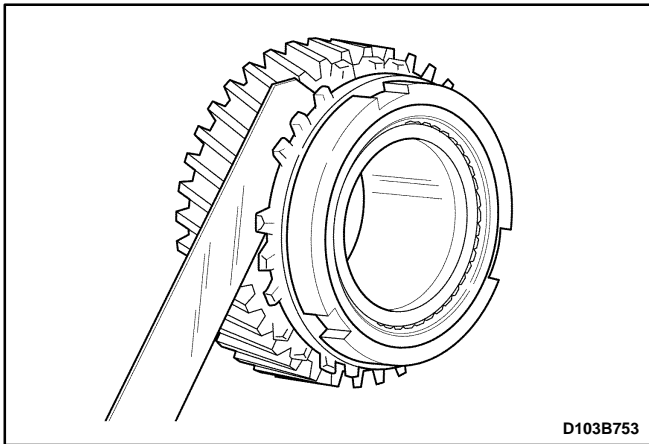

Synchronizer Assembly Inspection

1. Inspecting wear of cone area.

- After matching synchronizer ring to gear, measure as shown in figure. Replace if it is below limit.

Unit : mm (in.)

Clearance Between Gear and Ring	Standard	Limit
	1.0 (0.039)	0.5 (0.020)

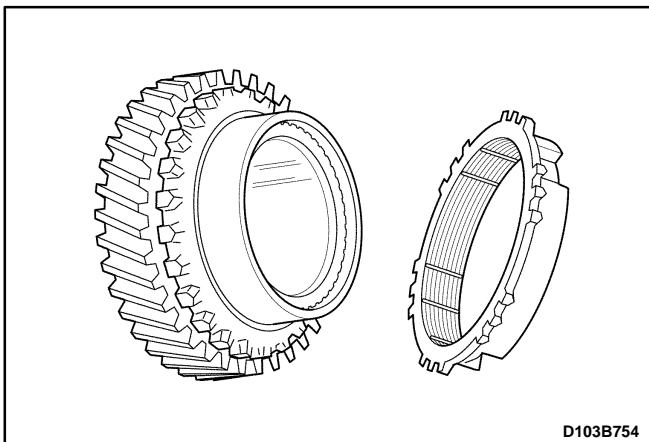

2. Inspecting cone contact condition.

- When synchronizer mechanism is abnormal in operation, connection between ring inner surface and gear cone area is considered to be partially defective in spite of correct clearance between gear and ring. Therefore, cone area and ring inner surface shall be inspected. In this case, ring inner surface shall be glossy. Black area is abnormal and if inspection is difficult, check after applying red lead. Cone area can be worn in wave form.

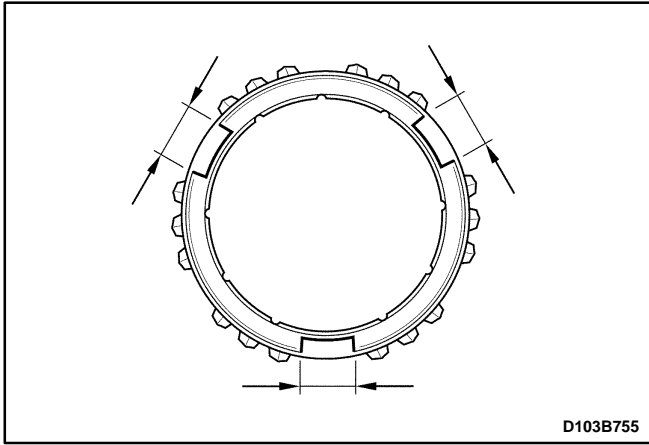

3. Inspecting key slot width of synchronizer ring.

- Measure key slot width of synchronizer ring. Replace if it exceeds limit.

Unit : mm (in.)

Key Slot Width	Standard	Limit
1st gear	8.2 (0.323)	8.6 (0.339)
2nd, 3rd, 4th gear	9.6 (0.378)	10.0 (0.394)
5th gear	9.4 (0.370)	9.8 (0.386)

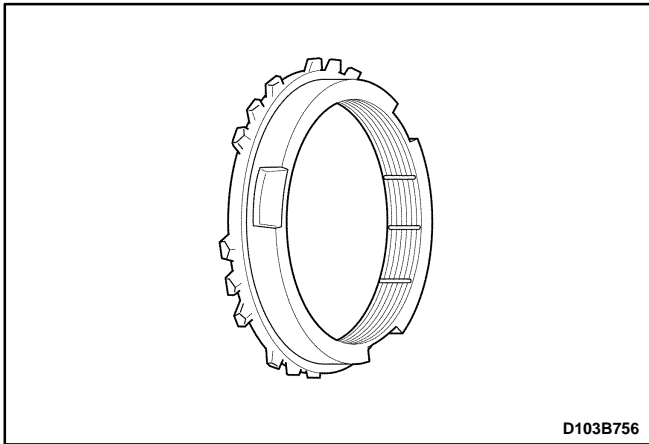

4. Inspecting wear of synchronizer ring.

- Check for worn or damaged synchronizer ring teeth. Replace if necessary.

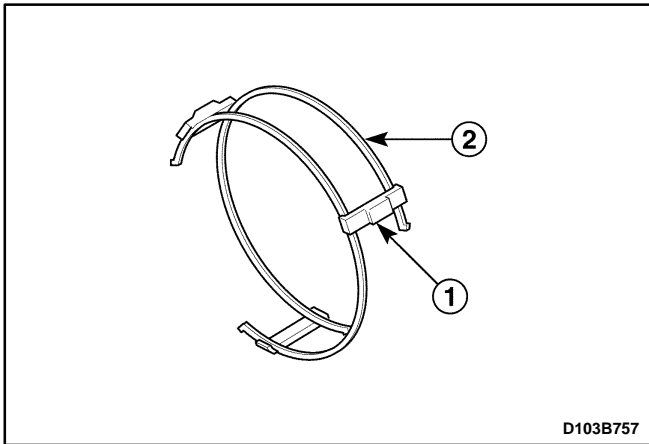

5. Inspecting synchronizer key and spring.

- Check for worn synchronizer key (1).
- Check for weak, damaged or broken spring (2).

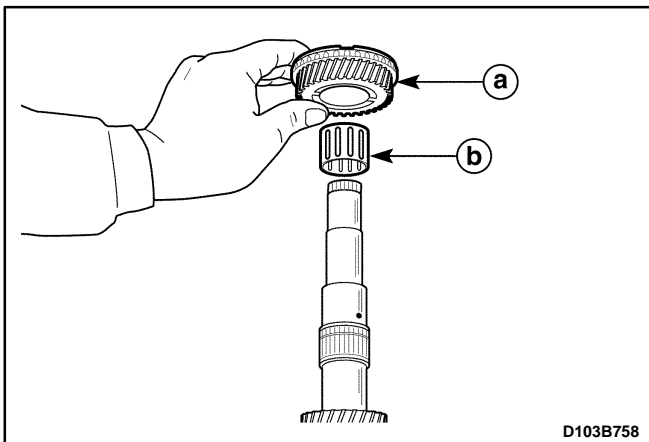

Assembly Procedure

1. Install the third gear bearing, the third gear / synchronizer ring.
 - a. Third gear / synchronizer ring.
 - b. Third gear bearing.

Important: Coat the inner parts; gear, bearing, oil seal etc. with gear fluid.

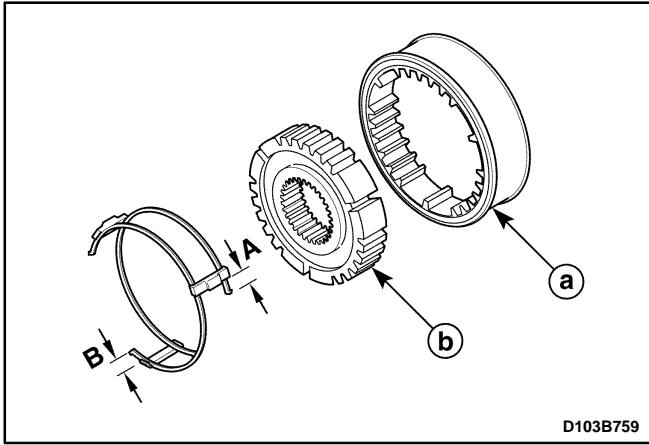

2. Assemble the third-fourth synchronizer hub assembly.

- Install the synchronizer springs to the hub.
- Install the synchronizer key to the hub.

Important: In case of assembling the synchronizer sleeve and the hub, let A=B.

- Install the hub to the sleeve.
 - a. Sleeve.
 - b. Hub.

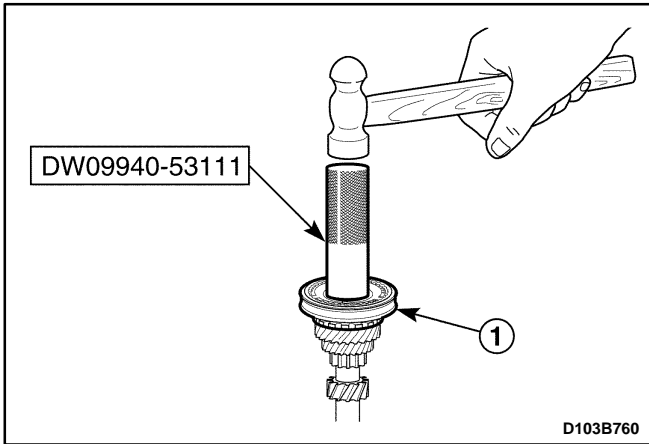

3. Install the third-fourth synchronizer hub assembly.

- Insert the hub assembly into the input shaft (1).

Important: Position the longer flange of hub toward the third gear and match the key and the ring groove.

- Install the hub assembly using a hammer and the gear, bearing installer DW09940-53111.

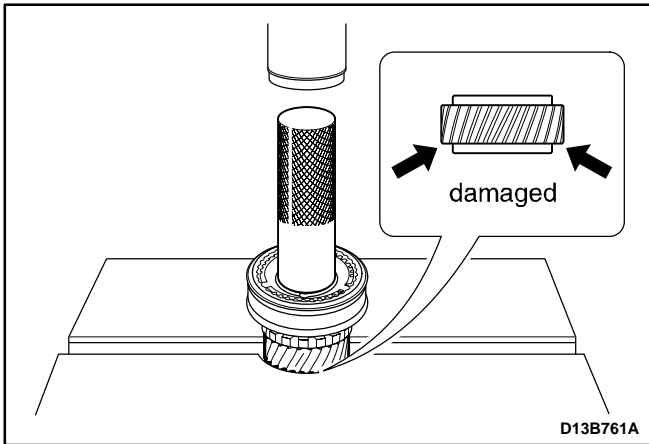

Notice: When installing gear, bearing and hub assembly, install them slowly using the gear, bearing installer DW09940-53111 and a hammer. If overpressed, the gear teeth may be damaged.

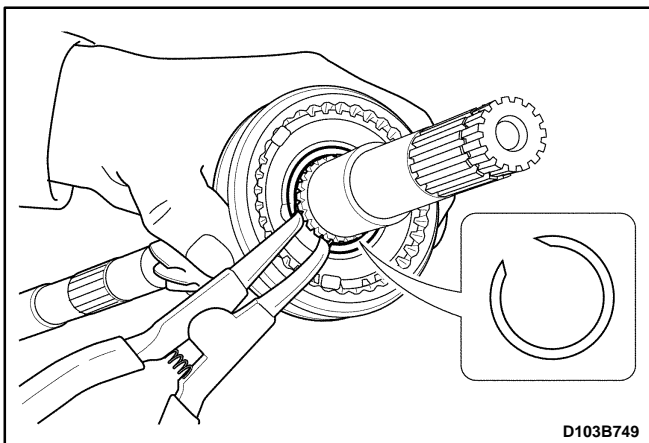

4. Install the third-fourth synchronizer circlip.

5. Install the fourth synchronizer ring and wave spring.

Important: Match the ring groove to the key of hub.

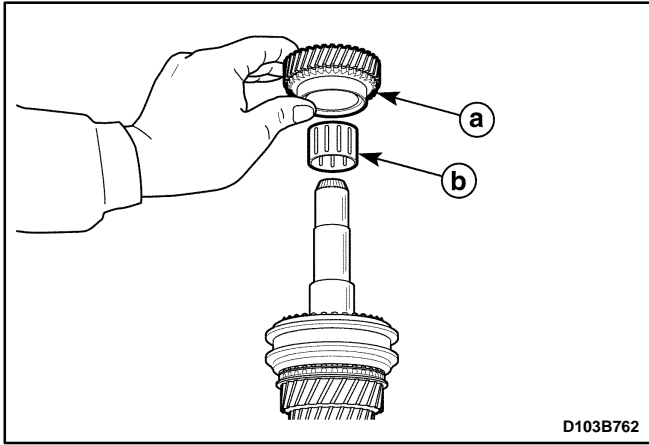

6. Install the input shaft fourth gear bearing and the fourth gear.
 - a. Fourth gear.
 - b. Fourth gear bearing.

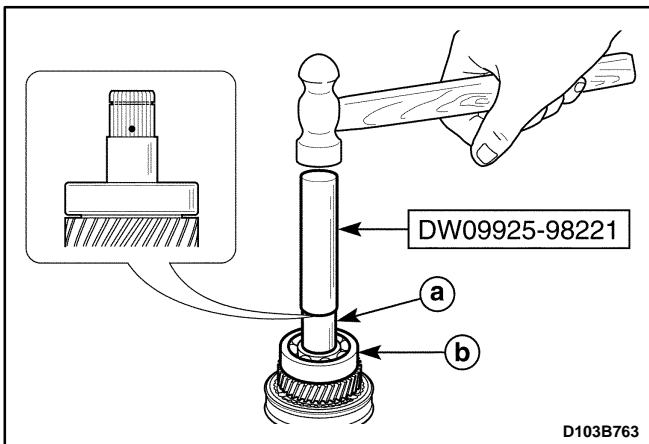

7. Install the input shaft left side bearing and the fifth gear spacer.
 - Install the following parts using the gear, bearing installer DW09925-98221 and a hammer.
 - a. Fifth gear spacer.
 - b. Input shaft left side bearing.

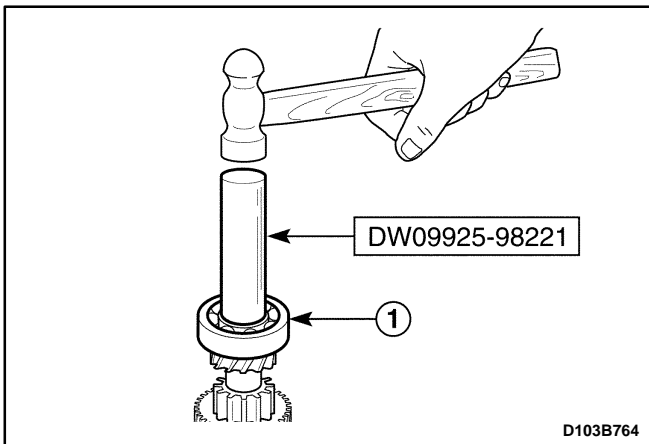

8. Install the input shaft right side bearing.
 - Install the bearing to the input shaft using the gear, bearing installer DW09925-98221 and a hammer (1).
9. Install the gear unit. Refer to "Gear Unit" in this section.

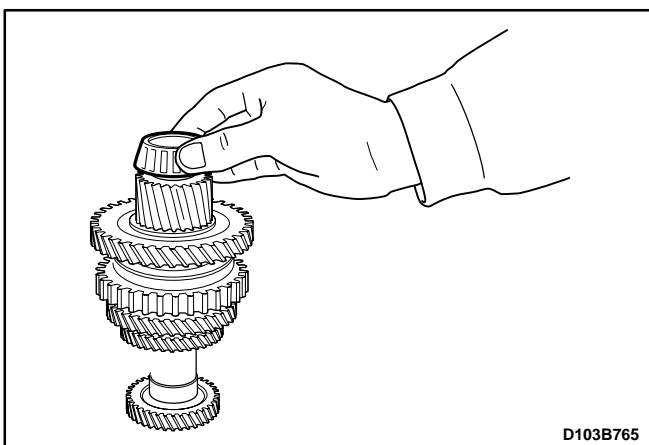

COUNTER SHAFT

Tools Required

09913-76010	Bushing, Seal Installer
DW09913-80112	Gear, Bearing Installer
DW09921-57810	Gear, Bearing Remover
DW09925-98221	Gear, Bearing Installer
DW09940-53111	Gear, Bearing Installer
DW220-020-01	Differential Bearing Puller
DW220-020-02	Differential Bearing Plate Adapter
DW220-020-03	Differential Bearing Plate Adapter
KM466-A	Gear, Bearing Remover/Installer

Disassembly Procedure

1. Remove the gear unit. Refer to "Gear Unit" in this section.
2. Remove the counter shaft right side bearing.

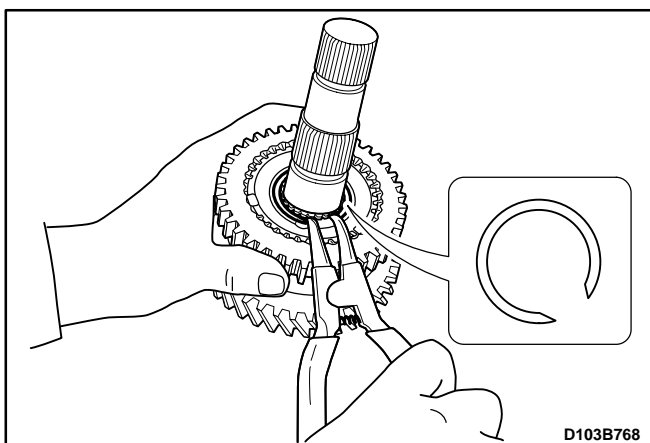
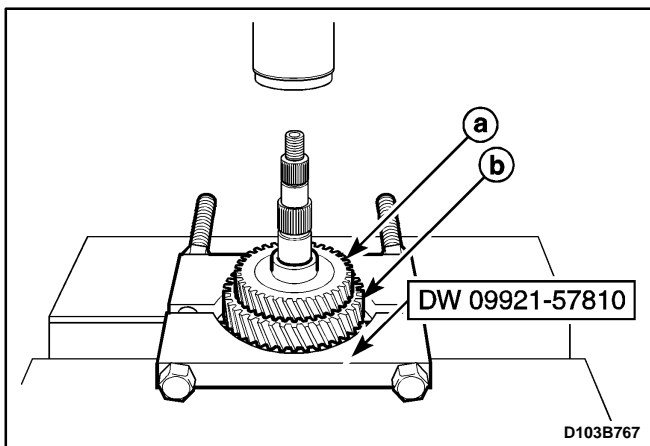
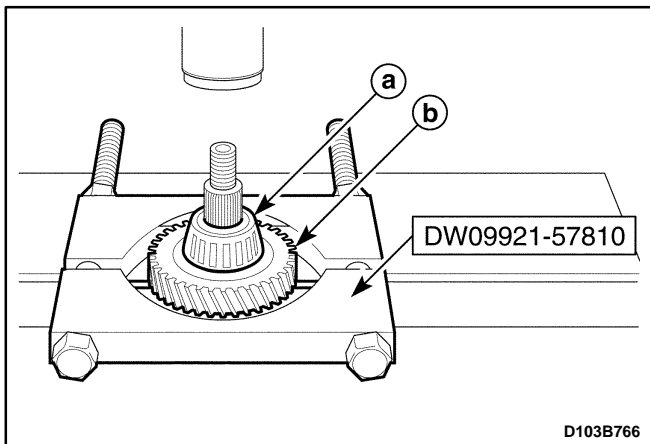

3. Remove the counter shaft left side bearing and the fourth gear.
 - Position the fourth gear to the gear, bearing remover DW09921-57810.
 - Remove the following parts by pressing.
 - a. Counter shaft left side bearing.
 - b. Fourth gear.
4. Remove the counter shaft third-fourth gear spacer.
5. Remove the counter shaft third gear and second gear.
 - Position the second gear to the gear, bearing remover DW09921-57810.
 - Remove the following parts by pressing
 - a. Third gear.
 - b. Second gear.
6. Remove the counter shaft second gear bearing.
7. Remove the second gear synchronizer ring.
8. Remove the first-second gear synchronizer circlip.

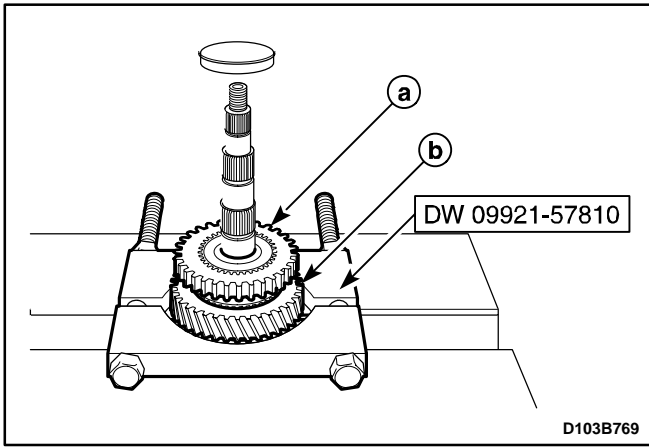

9. Remove the counter shaft first-second gear synchronizer hub assembly, the first gear / the first gear synchronizer ring.
 - Position the first gear to the gear, bearing remover DW09921-57810.
 - Remove the following parts by pressing.
 - a. Synchronizer hub assembly.
 - b. First gear / First gear synchronizer ring.
 - Remove the first gear synchronizer ring from the first gear.

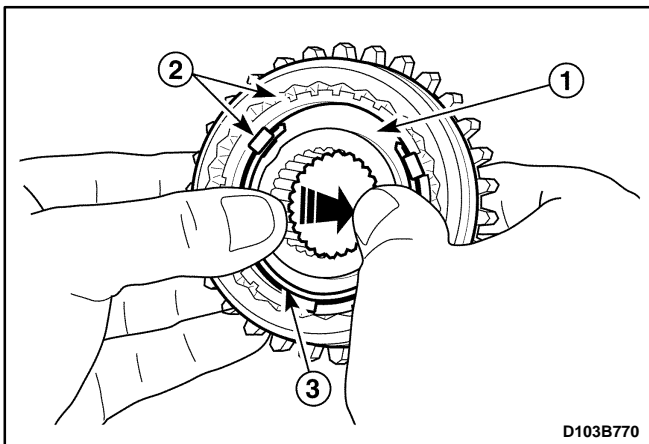

10. Disassemble the first-second gear synchronizer hub assembly.
 - Push the hub from the hub assembly (1).
 - Disassemble the synchronizer sleeve and key (2).
 - Disassemble the synchronizer springs (3).

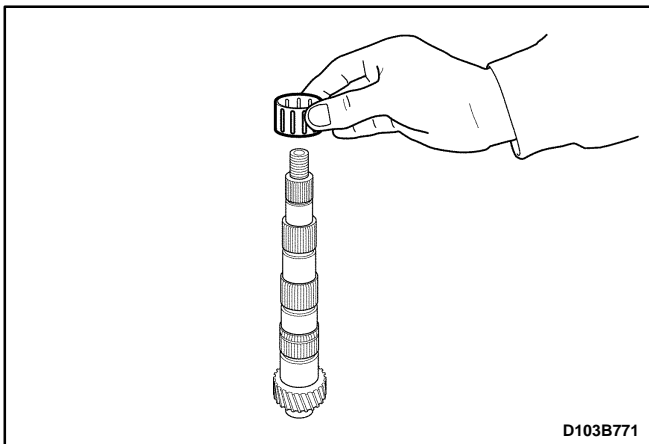

11. Remove the counter shaft first gear bearing.

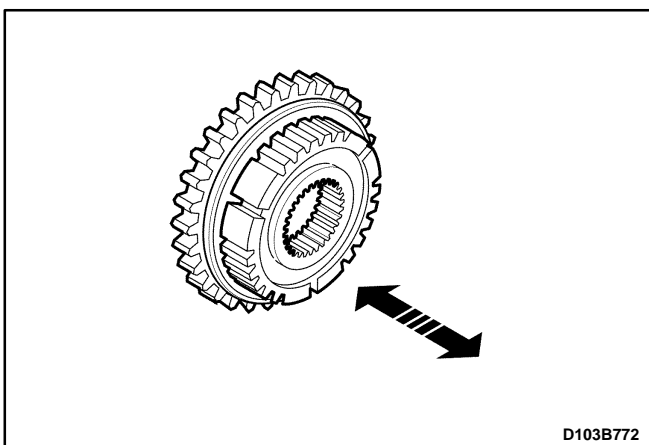

Synchronizer Hub and Sleeve Inspection

- Check the sleeve for improper operation after assembling the hub and the sleeve.
- Check the wear of hub and sleeve.
- Replace synchronizer hub or sleeve if necessary.

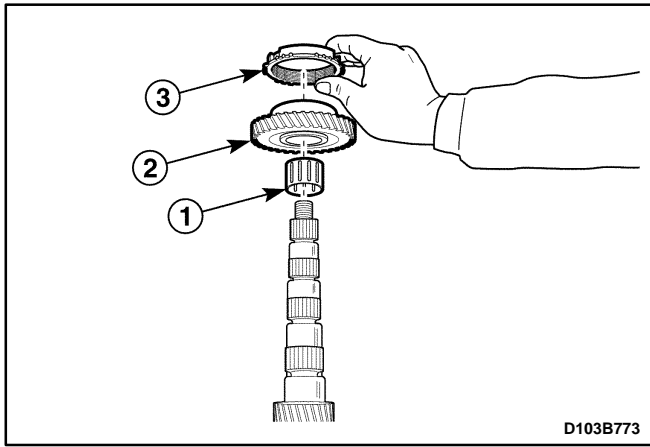

D103B773

Assembly Procedure

1. Install the related counter shaft first gear.
 - Install the first gear bearing (1).
 - Install the first gear (2).
 - Install the first gear synchronizer ring (3)

Important: Coat the inner parts; gear, bearing and oil seal etc. with gear fluid.

Important: Be careful there is the difference of key groove width between the first synchronizer ring and the second synchronizer ring.

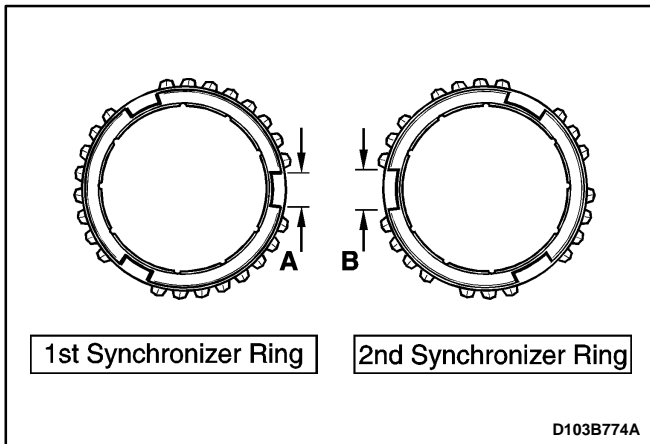

D103B774A

Unit : mm (in.)

Key Groove Width	First synchronizer ring (A) : 8.2 (0.323)
	Second synchronizer ring (B) : 9.6 (0.378)

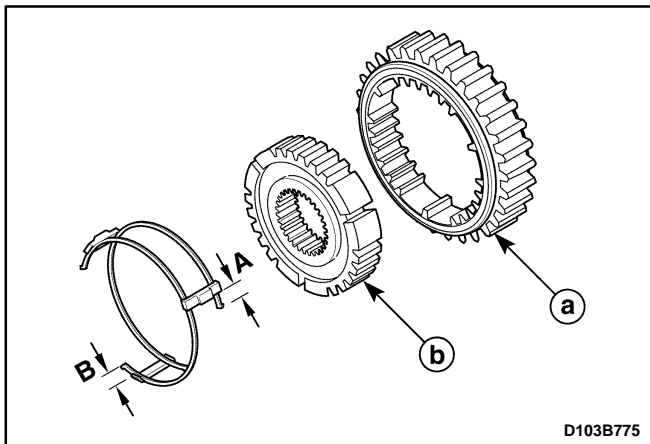

D103B775

2. Assemble the first-second synchronizer hub assembly.
 - Install the synchronizer springs to hub.
 - Install the synchronizer keys to hub.

Important: Let (A)=(B) when installing the keys.

- Install the hub to the sleeve.
 - a. Sleeve.
 - b. Hub.

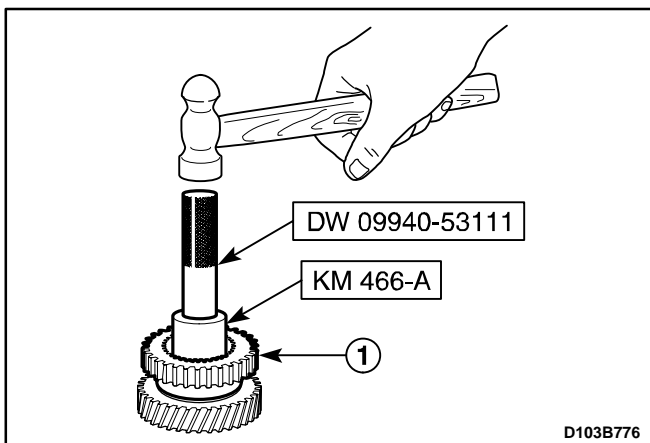

D103B776

3. Install the first-second synchronizer hub assembly.
 - Insert the hub assembly into the counter shaft using the gear, bearing installer DW09940-53111, the gear bearing remover/installer KM466-A and a hammer (1).

Important: Position the synchronizer key to the first gear synchronizer ring groove.

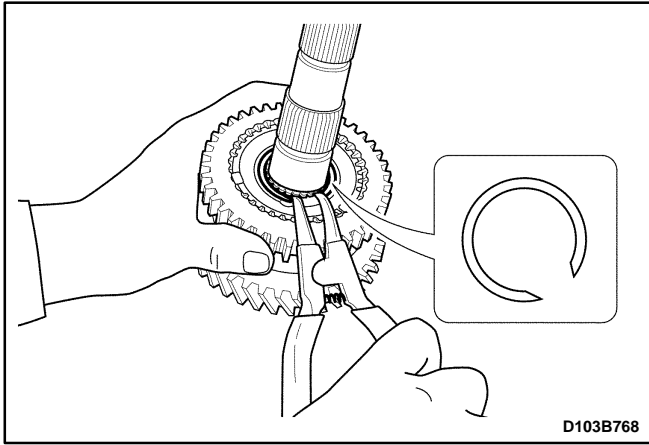

4. Install the second synchronizer ring.

Important: Position the second synchronizer ring groove to the synchronizer hub key.

5. Install the first–second gear synchronizer circlip.

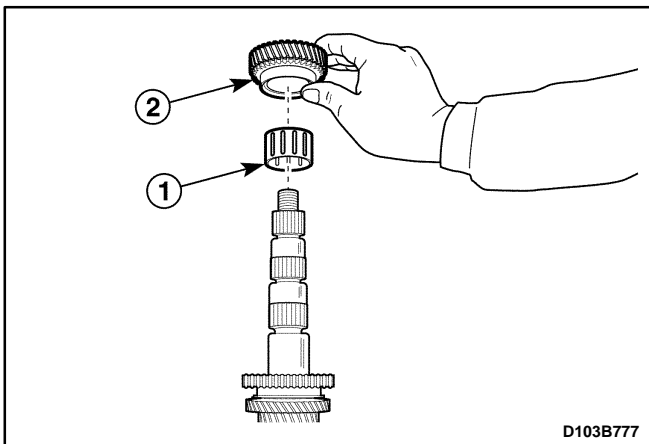

6. Install the related counter shaft second gear.

- Install the second gear bearing (1).
- Install the second gear (2).

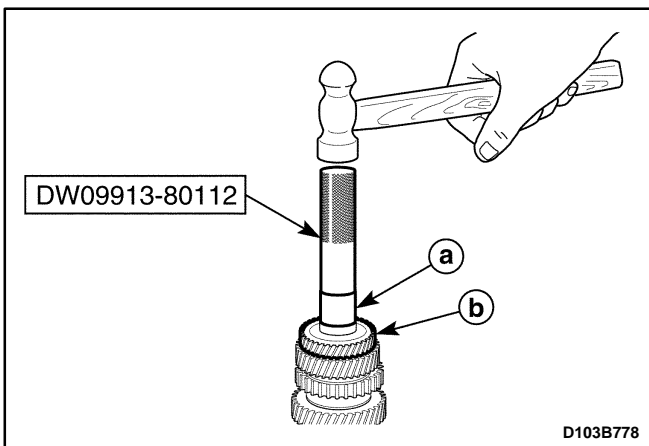

7. Install the counter shaft third gear and the third–fourth gear spacer.

- Insert the third gear and the third–fourth gear spacer into the counter shaft.
- Install the following parts using the gear, bearing installer DW09913–80112 and a hammer.
 - a. Third–fourth gear spacer.
 - b. Third gear.

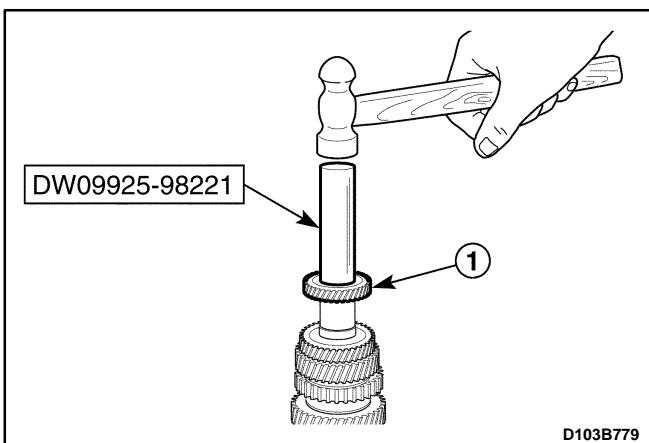

8. Install the counter shaft fourth gear.

- Install the fourth gear to the counter shaft using the gear, bearing installer DW09925–98221 and a hammer (1).

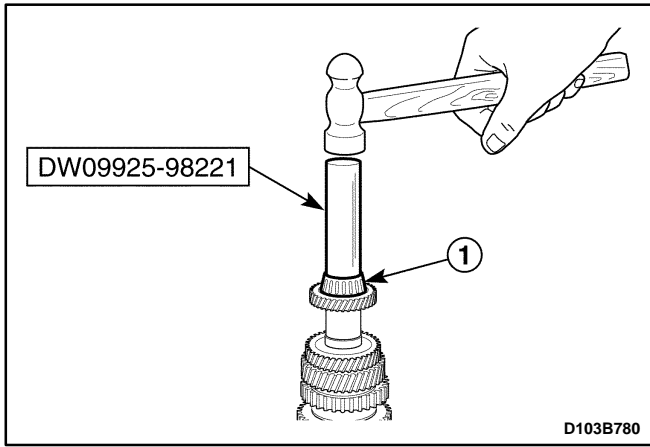

9. Install the counter shaft left side bearing.
 - Install the left side bearing to the counter shaft using the gear, bearing installer DW09925-98221 and a hammer (1).

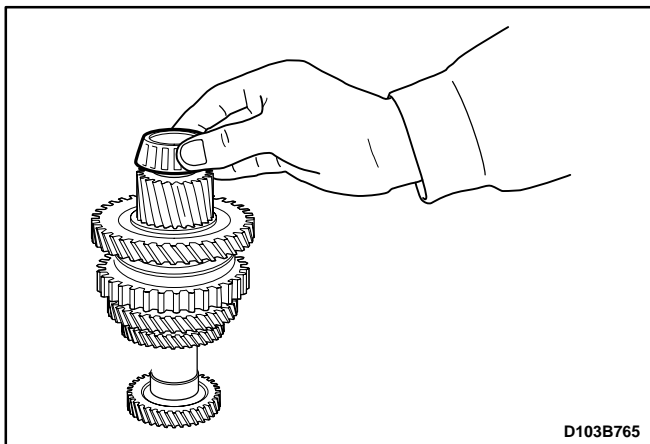

10. Install the counter shaft right side bearing.
11. Install the gear unit. Refer to "Gear Unit" in this section.

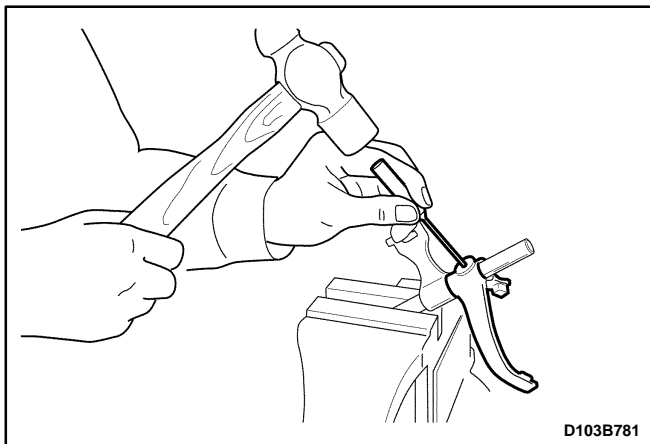

GEAR SHIFT FORK

Disassembly Procedure

1. Remove the gear unit. Refer to "Gear Unit" in this section.
2. Remove the each shift shaft assembly from the gear unit.
3. Remove the first-second gear shift shaft assembly.
 - Fix the shift shaft assembly to a vise with protector.
 - Remove the first-second gear fork pin using a pin punch and a hammer (1).
 - Remove the first-second gear shift fork (2).
- Remove the first-second gear shift yoke pin using a pin punch and a hammer (3).
- Remove the first-second gear shift yoke (4).

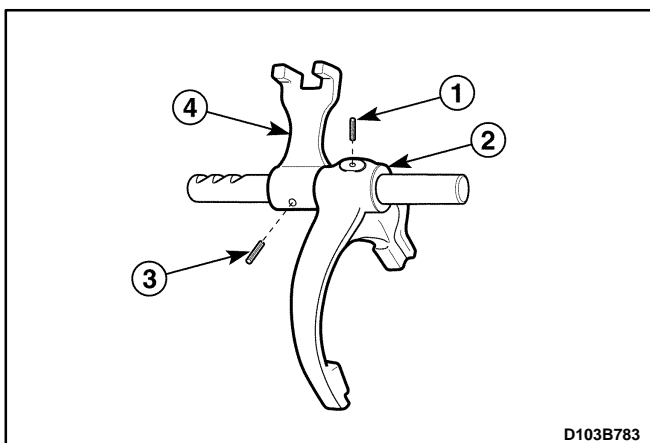

Important: Mark the place and direction of shift fork and yoke to install easily before removing them.

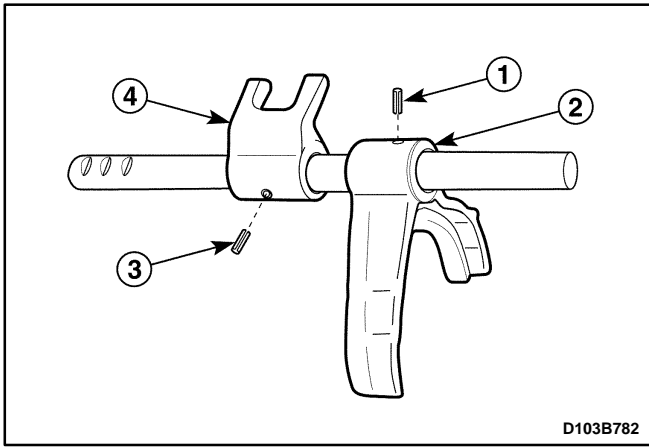

4. Disassemble the third-fourth gear shift shaft assembly.
 - Fix the third-fourth gear shift shaft assembly to a vise with protector.
 - Remove the third-fourth gear fork pin using a pin punch and a hammer (1).
 - Remove the third-fourth gear fork (2).
 - Remove the third-fourth gear shift yoke pin using a pin punch and a hammer (3).
 - Remove the third-fourth gear shift yoke (4).

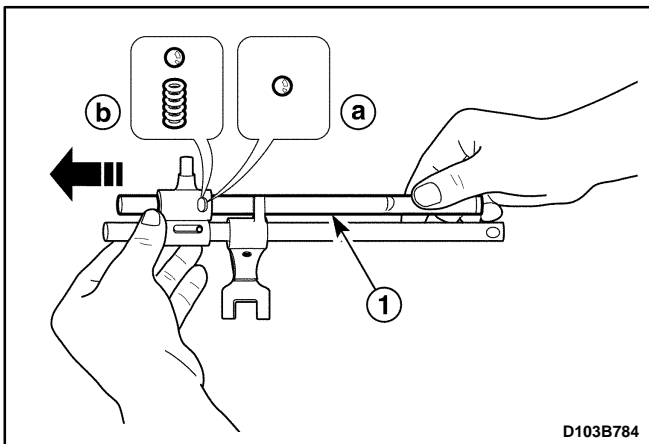

5. Disassemble the fifth-reverse gear shift shaft assembly.
 - Remove the shift shaft not installed with yoke by pushing (1).
 - Remove the following parts from the reverse shift arm.
 - a. Fifth-reverse gear ball.
 - b. Reverse shift guide ball and spring.
 - Fix the shift shaft assembly to a vise with protector.
 - Remove the reverse gear shift arm pin using a pin punch and a hammer (2).
 - Remove the reverse gear shift arm (3).

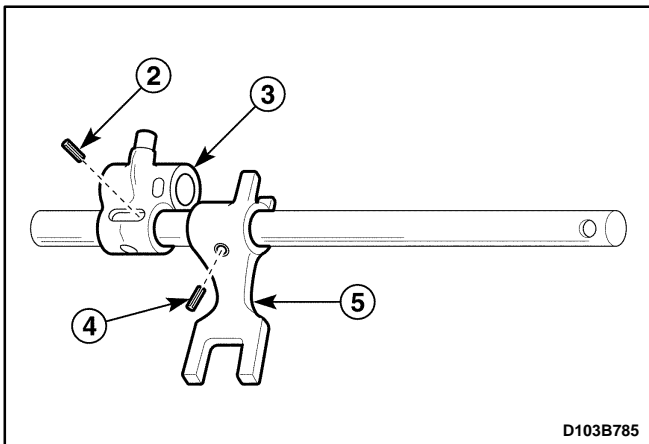

- Remove the fifth gear shift yoke pin using a pin punch and a hammer (4).
- Remove the fifth gear shift yoke (5).

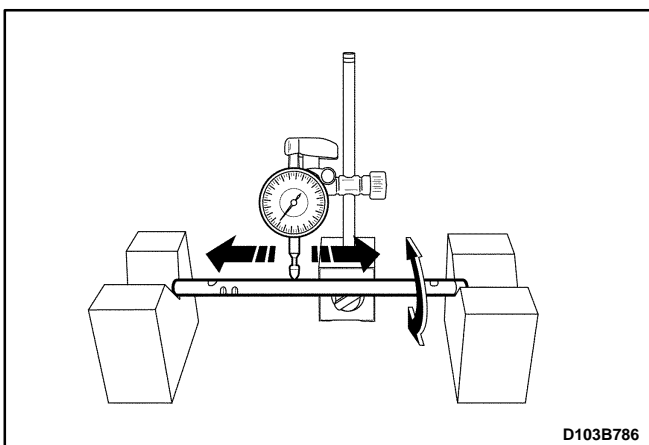

Inspection Procedure – Shift Shaft

1. Check for bent, deformed or damaged shift shaft.
2. Replace shift shaft if necessary.

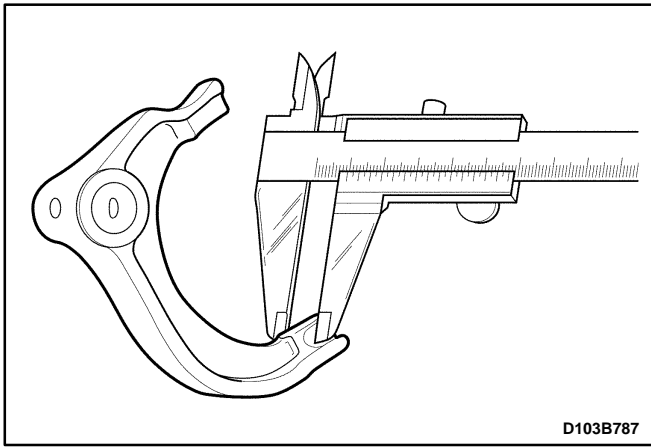

D103B787

Inspection Procedure – Shift Fork

1. Measure the end thickness of shift fork and replace if below limit.

Unit : mm (in.)

Shift fork end thickness (mm)	Standard	Limit
Low Speed Shift Fork	8.7 (0.343)	8.1 (0.319)
High Speed Shift Fork	7.8 (0.307)	7.2 (0.283)
Fifth Gear Shift Fork	7.8 (0.307)	7.2 (0.283)

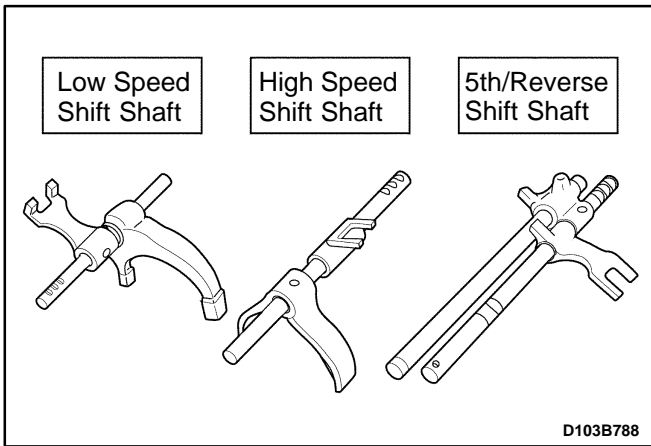

D103B788

Assembly Procedure

1. Install in the reverse order of removal.

Important: Use only new fork fin and yoke pin.

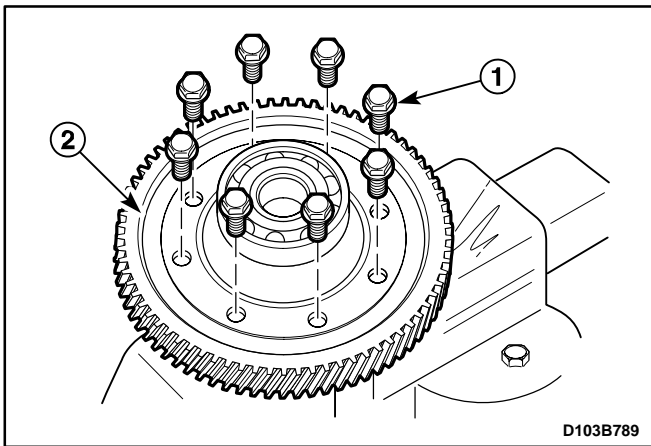

D103B789

DIFFERENTIAL

Disassembly Procedure

1. Remove the differential assembly. Refer to "Gear Unit" in this section.
2. Remove the differential ring gear.
 - Fix the differential assembly to a vise with protector.
 - Remove the bolts (1).
 - Remove the ring gear (2).
3. Remove the pinion gear pin.
 - Remove the pin using a pin punch and a hammer (1).

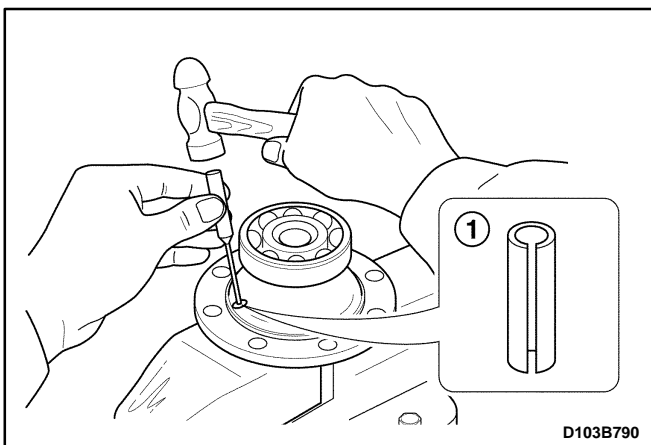

D103B790

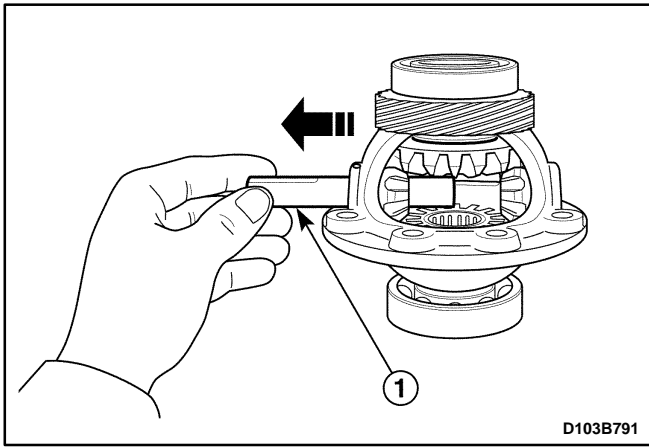

4. Remove the pinion gear shaft.
- Remove the shaft from the case (1).

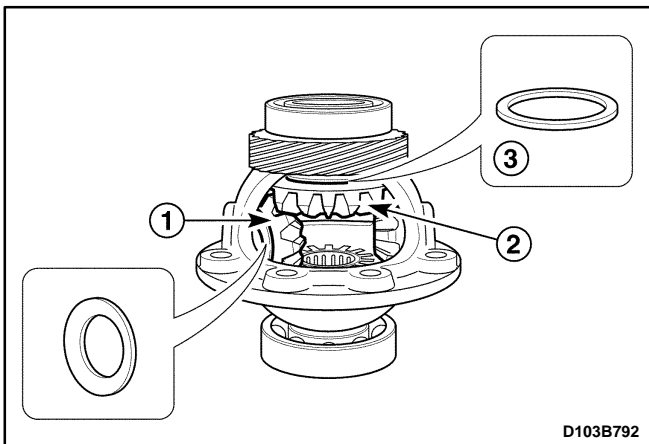

5. Remove the pinion gears and the side gears.
- Remove the pinion gears and the washers (1).
- Important:** Remove the pinion gear and the washer by rotating the side gear.
- Remove the side gears (2).
 - Remove the adjust shims from the side gears (3).

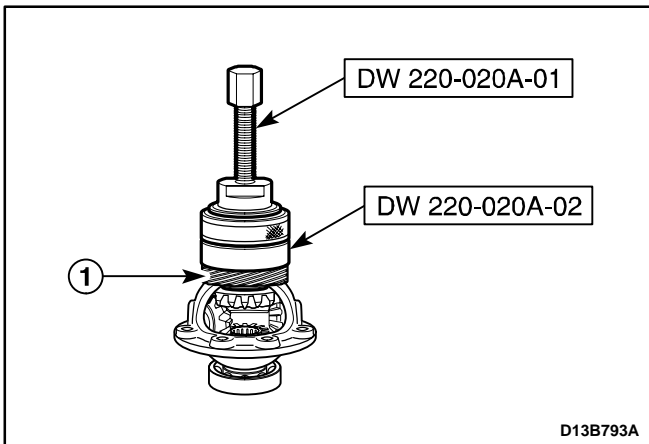

6. Remove the differential right side bearing and speedometer drive gear.
- Remove the right side bearing using the differential bearing puller DW220-020A-01 and the differential bearing plate adapter DW220-020A-02.
 - Remove the speedometer drive gear (1).

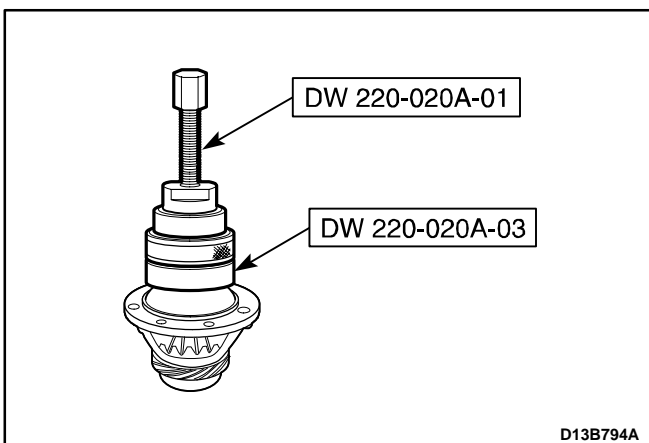

7. Remove the differential left side bearing.
- Remove the left side bearing using the differential bearing puller DW220-020A-01 and the differential bearing plate adapter DW220-020A-03.

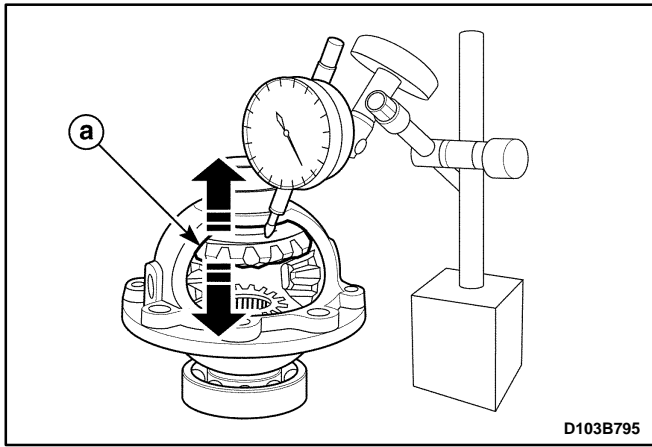

Side Gear Play Inspection

1. Measure the axle direction play of side gear and replace a side gear washer if it exceeds limit.

UNIT : mm (in.)

Thrust Free Play of Differential Side	0.05-0.33 (0.0020-0.0130)
---------------------------------------	------------------------------

UNIT : mm (in.)

Thrust Adjusting Shim	0.90 (0.0354) 0.95 (0.0374)
	1.00 (0.0394) 1.05 (0.0413)
	1.10 (0.0433) 1.15 (0.0453)
	1.20 (0.0472)

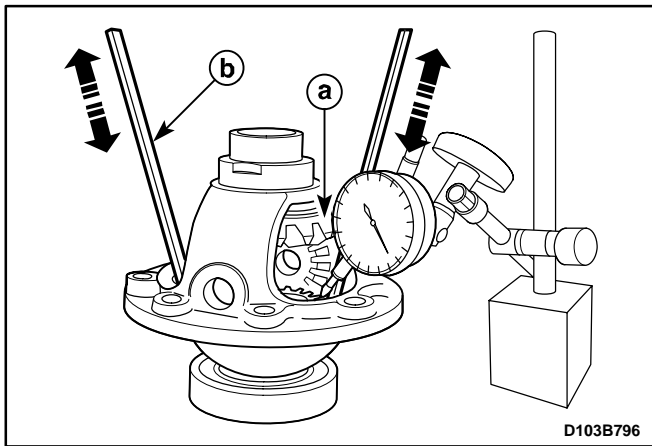

2. After checking for worn or scratched thrust adjusting shim, replace it if necessary.

- a. Side gear.
- b. Driver.

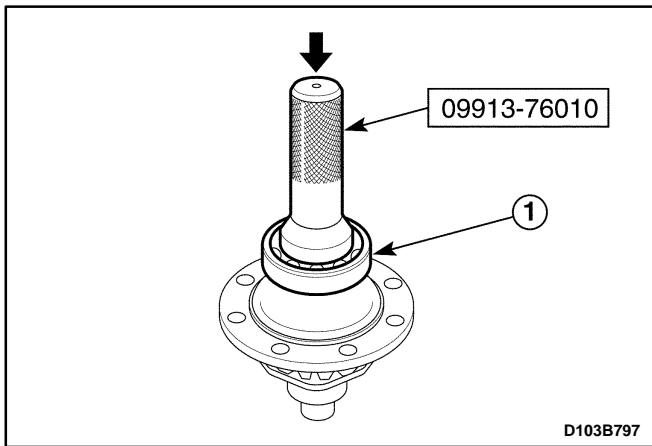

Assembly Procedure

1. Install the differential left side bearing.
 - Insert the left side bearing (1).
 - Install the left side bearing using the bushing, seal installer 09913-76010 and a hammer.

Important: Coat the inner parts; bearing, washer, shim etc. with gear fluid.

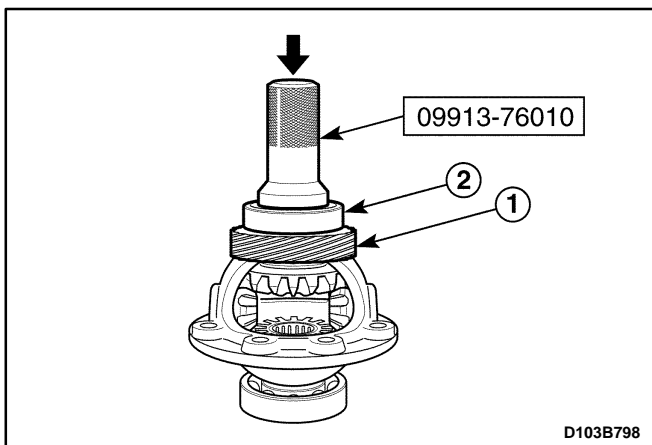

2. Install the speedometer drive gear and differential right side bearing.

- Insert the speedometer drive gear(1).
- Insert the differential right side bearing (2).
- Install the right side bearing using the bushing, seal installer 09913-76010 and a hammer.

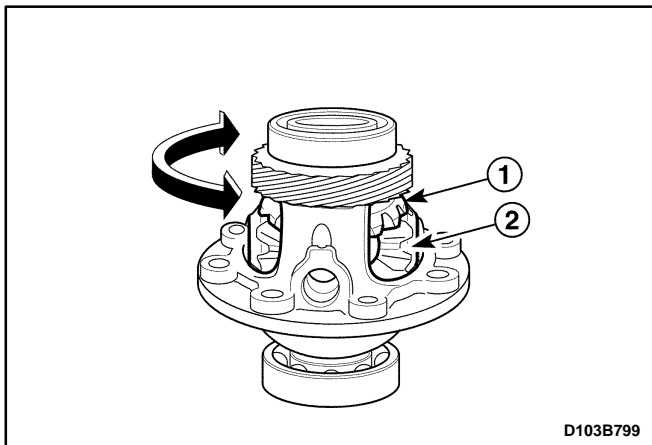

3. Install the side gears and the pinion gears.
 - Insert the trust adjusting shims to the side gears.
 - Install the side gears (1).
 - Install the pinion gears and washers (2).

Important: Install the pinion gears and washers simultaneously.

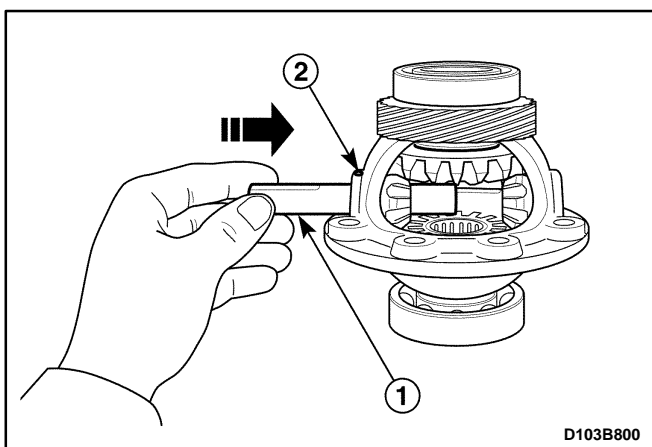

4. Install the pinion gear shaft and pin.
 - Insert the shaft into the gear pin hole by rotating (1).
 - Press the pin using a pin punch and a hammer (2).

Important: Use only new pin.

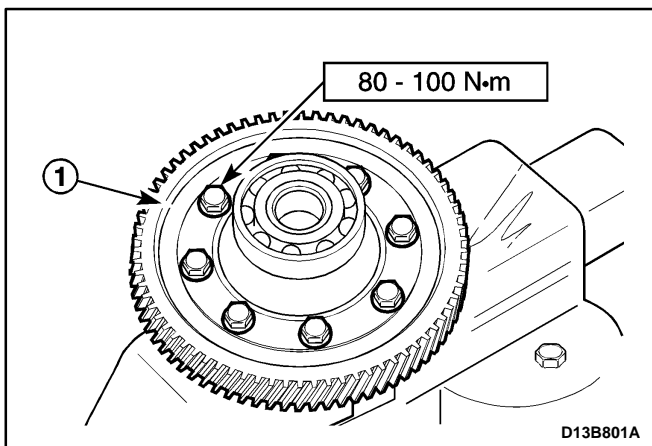

5. Install the differential ring gear.
 - Fix the differential assembly to a vise.
 - Install the ring gear with the bolts (1).

Tighten

Tighten the bolts to 80–100 N•m (59–74 lb-ft).

6. Install the differential assembly. Refer to “Gear Unit” in this section.

SPECIFICATIONS

GENERAL SPECIFICATIONS

Application	Description		Unit	Standard	Limit
General	Type	Forward gear	–	Synchronized mesh type	–
		Reverse gear	–	Sliding mesh type	–
	Gear ratio	1st	–	3.818	–
		2nd	–	2.210	–
		3rd	–	1.423	–
		4th	–	1.029	–
		5th	–	0.837	–
		Reverse	–	3.583	–
	Final drive ratio		–	4.444	–
	Fluid capacity		L(qt)	2.1 (2.21)	–
Fluid classification		–	75W-85 (GL-4)	–	
Service	Key groove width of synchronizer ring	1st gear	mm(in.)	8.2 (0.323)	8.6 (0.339)
		2nd, 3rd, 4th gear	mm(in.)	9.6 (0.378)	10.0 (0.394)
		5th gear	mm(in.)	9.4 (0.370)	9.8 (0.386)
	Shift fork end thickness	Low speed shift fork (1st~2nd)	mm(in.)	8.7 (0.343)	8.1 (0.319)
		High speed shift fork (3rd~4th)	mm(in.)	7.8 (0.307)	7.2 (0.283)
		5th gear shift fork	mm(in.)	7.8 (0.307)	7.2 (0.283)
	Clearance between gear and synchronizer ring		mm(in.)	1.0 (0.039)	0.5 (0.020)
	Clearance between sleeve and shift fork		mm(in.)	0.2 – 0.6 (0.008 – 0.024)	1.0 (0.039)
	Thrust free play of differential side gear		mm(in.)	0.05 – 0.33 (0.002 – 0.013)	–
	Speedometer gear ratio(Driven/Drive)		–	17/18 (0.944)	–

FASTENER TIGHTENING SPECIFICATIONS

Application	N•m	Lb-Ft	Lb-In
5th/Reverse Gear Shift Shaft Bolt	10 – 16	7 – 12	–
Back Up Light Switch Nut	15 – 18	11 – 13	–
Counter Shaft 5th Gear Nut	60 – 80	44 – 59	–
Crankshaft Position Sensor Bolt	5 – 8	–	44 – 70
Differential Ring Gear Bolt	80 – 100	59 – 74	–
Engine Mounting Front Bracket Bolt (Cylinder Block Side)	35 – 41	25 – 30	–
Engine Mounting Front Damping Bush Bolt (Crossmember Side)	35 – 41	25 – 30	–
Engine Mounting Front Damping Bush Bolts (Crossmember Side)	45 – 55	33 – 41	–
Engine Mounting Front Damping Bush Bolt/Nut (Bracket Side)	68 – 83	51 – 61	–
Front Exhaust Pipe Nut (Exhaust Manifold Side/Muffler Side)	25 – 35	18 – 25	–
Gear Shift Control Case Bolt	18 – 28	13 – 21	–
Gear Shift Lever Bolt	4 – 7	–	35 – 62
High Speed Shift Shaft Bolt	10 – 16	7 – 12	–
Low Speed Shift Shaft Bolt	10 – 16	7 – 12	–
Oil Drain Plug	25 – 30	18 – 22	–
Oil Level Plug	36 – 54	26 – 40	–
Radiator Lower Hose Bracket Bolts	8 – 15	–	70 – 132
Reverse Idle Gear Shaft Bolt	18 – 28	13 – 21	–
Reverse Shift Lever Bolt	18 – 28	13 – 21	–
Select Cable Nut(Shift Lever Side)	8 – 12	–	71 – 106
Select Lever Bolt	18 – 28	13 – 21	–
Side Cover Plate Screw	6 – 7	–	53 – 62
Shift Guide Bolt	18 – 28	13 – 21	–
Shift Interlock Bolt	18 – 28	13 – 21	–
Side Cover Bolt	8 – 12	–	71 – 106
Speedometer Driven Gear Bolt	4 – 7	–	35 – 62
Starter Motor Bolt	18 – 28	13 – 21	–
Transaxle Case Bolt	15 – 22	11 – 16	–
Transaxle Case(left) Cap Bolt	8 – 12	–	71 – 106
Transaxle Lower Bolt and Nut(Engine Side)	55 – 65	41 – 48	–
Transaxle Mounting Bolt(Body Side)	45 – 55	33 – 41	–
Transaxle Mounting Bolt and Nut(Transaxle Side)	55 – 65	41 – 48	–
Transaxle Upper Bolt(Engine Side)	55 – 65	41 – 48	–
Transaxle Under Cover Bolt	35 – 55	25 – 41	–

SPECIAL TOOLS

SPECIAL TOOLS TABLE

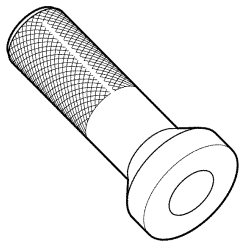
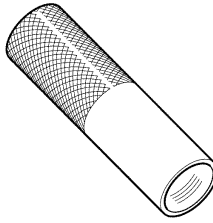
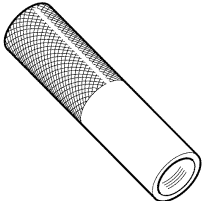
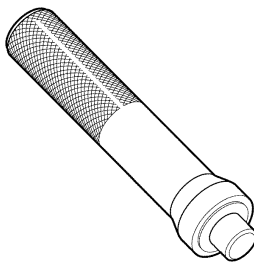
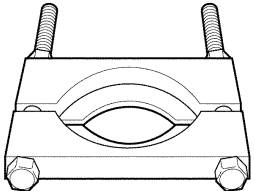
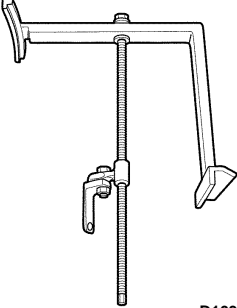
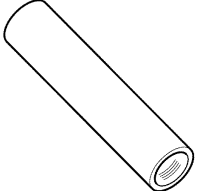
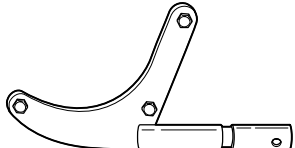
 <p>D103B110</p>	<p>09913-76010 Bushing, Seal Installer</p>	 <p>D103B105</p>	<p>DW09940-53111 Gear, Bearing Installer</p>
 <p>D103B106</p>	<p>DW09913-80112 Gear, Bearing Installer</p>	 <p>D103B109</p>	<p>DW09943-78210 Bushing, Seal Installer</p>
 <p>D103B104</p>	<p>DW09921-57810 Gear, Bearing Remover</p>	 <p>D103B103</p>	<p>DW110-021 Engine Assembly Support Fixture</p>
 <p>D103B107</p>	<p>DW09925-98221 Gear, Bearing Installer</p>	 <p>D13B101A</p>	<p>DW220-010A Transaxle Fixture</p>

SPECIAL TOOLS TABLE (Cont'd)

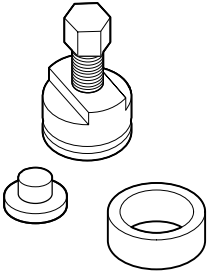
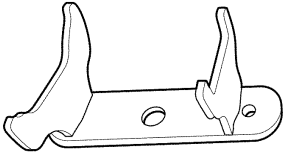
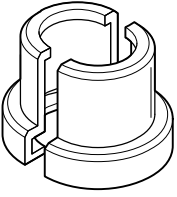
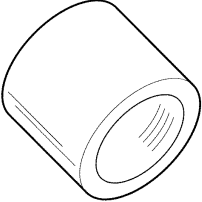
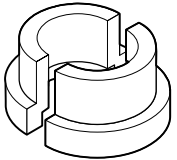
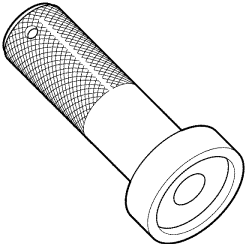
 <p>D13B112A</p>	<p>DW220-020A-01 Differential Bearing Puller</p>	 <p>D103B102</p>	<p>DW220-031 Transaxle Remove/ Install Support</p>
 <p>D13B113A</p>	<p>DW220-020A-02 Differential Bearing Plate Adapter</p>	 <p>D103B108</p>	<p>KM466-A Gear, Bearing Remover / Installer</p>
 <p>D13B114A</p>	<p>DW220-020A-03 Differential Bearing Plate Adapter</p>	 <p>D103B111</p>	<p>KM519 Oil Seal Installer</p>