SECTION 4B

MASTER CYLINDER

TABLE OF CONTENTS

Description and Operation	4B-2	Brake Fluid Reservoir	4B-5
Master Cylinder	4B-2	Proportioning Valve (For Vehicle With the Non-ABS Braking System)	4B-5
Proportioning Valve	4B-2	Brake Fluid Level Switch	4B-6
Fluid Level Sensor	4B-2	Unit Repair	4B-8
Diagnostic Information and Procedures	4B-3	Master Cylinder	4B-8
Checking the Brake Fluid Level	4B-3	Specifications	4B-9
Repair Instructions	4B-4	Fastener Tightening Specifications	4B-9
On-Vehicle Service	4B-4		
Master Cylinder Assembly	4B-4		

DESCRIPTION AND OPERATION

MASTER CYLINDER

The master cylinder is designed for use in a direct-split system. Front right brake and rear left brake are served by the primary piston. Front left brake and rear right brake are served by the secondary piston.

The master cylinder incorporates the functions of the standard dual master cylinder, plus a low fluid level indicator and the proportioning valve in the non-antilock braking system.

The proportioning valves limit the outlet pressure to the rear brakes after a predetermined master cylinder has been reached.

Important:

- Replace all the components included in the repair kits used to service this master cylinder.
- Lubricate rubber parts with clean brake fluid to ease assembly.
- Do not use lubricated shop air on brake parts, as this may damage rubber components.
- If any hydraulic component is removed or disconnected, it may be necessary to bleed all or part of the brake system.

- The torque values specified are for dry, unlubricated fasteners.
- Perform all service operations on a clean bench, free from all traces of mineral oil.

PROPORTIONING VALVE

The proportioning valve limits the outlet pressure to the rear brakes on the non-ABS after a predetermined master cylinder pressure has been reached. This is used when less rear apply force is needed to obtain optimum braking and is usually found on disc/drum brake configurations. On ABS-equipped vehicles, refer to *Section 4F, Antilock Brake System*.

FLUID LEVEL SENSOR

Fluid level sensor is attached at the brake fluid reservoir. This sensor will activate the BRAKE light if a low fluid level condition is detected. Once the fluid level is corrected, the BRAKE light will go out.

DIAGNOSTIC INFORMATION AND PROCEDURES

CHECKING THE BRAKE FLUID LEVEL

1. Check the fluid level.
2. If the fluid level is below MAX, refill the fluid to MAX.

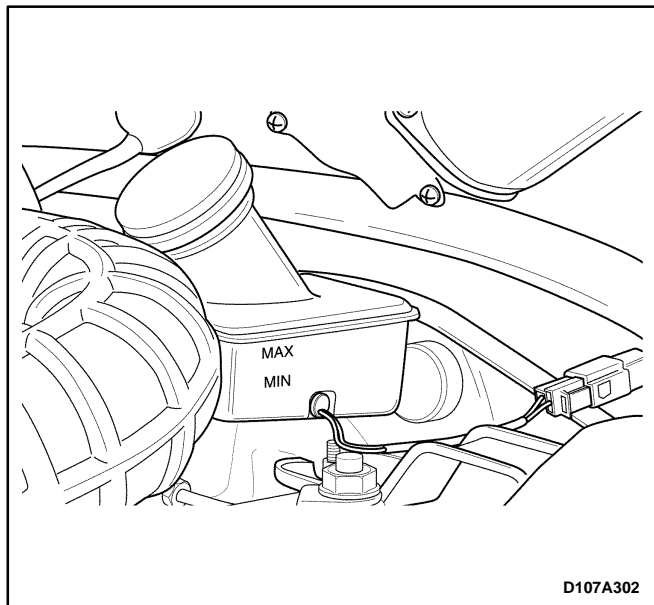

REPAIR INSTRUCTIONS

ON-VEHICLE SERVICE

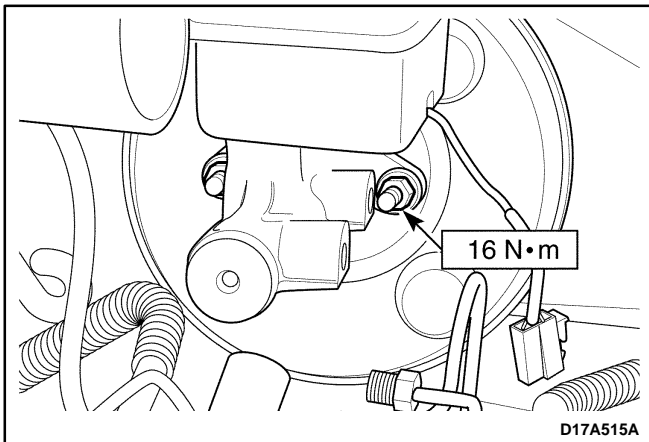
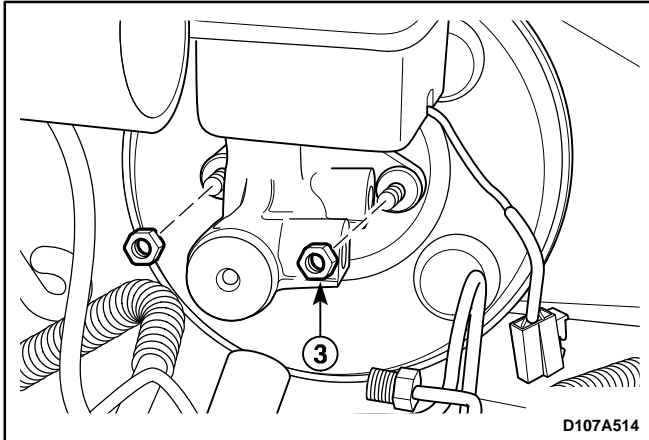
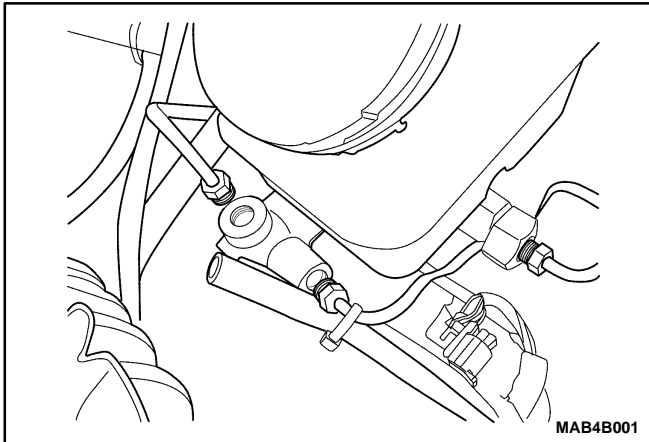

MASTER CYLINDER ASSEMBLY

Removal Procedure

1. Remove the air filter assembly. Refer to *Section 1B, Engine Mechanical*.
2. For vehicles with the non-ABS braking system, remove the proportioning valve. Refer to "Proportioning Valve" in this section.
3. Remove the master cylinder.
 - Disconnect the electrical connector.
 - Loosen the brake pipe fittings.
 - Plug the opening in the master cylinder to prevent fluid loss or contamination.

Notice: Brake fluid may damage paintwork, if spillage onto paintwork, wash with cold water immediately.

- Remove the nuts mounting the master cylinder (3).

Installation Procedure

Important: Use only Daewoo recommended brake fluid.

1. Install the master cylinder assembly with the nuts.

Tighten

Tighten the attaching nuts to 16 N•m (12 lb-ft).

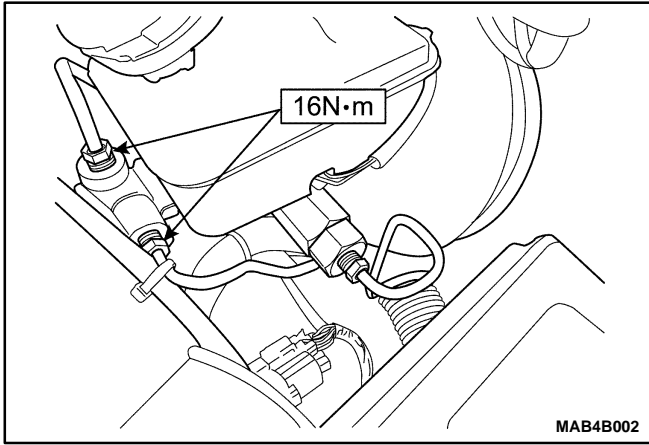

2. Install the brake pipe fittings to the master cylinder.

Tighten

Tighten the fittings to 16 N·m (12 lb-ft).

3. Connect the electrical connector.
4. For vehicles with the non-ABS braking system, install the proportioning valve. Refer to "Proportioning Valve" in this section.
5. Install the air filter assembly. Refer to *Section 1B, Engine Mechanical*.
6. Bleed the brake system. Refer to *Section 4A, Hydraulic Brakes*.

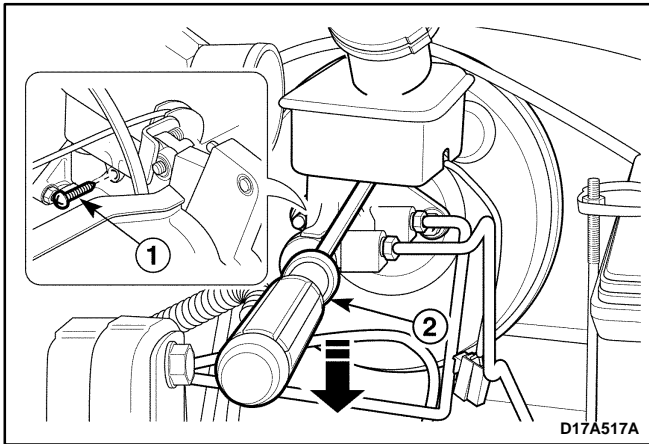

BRAKE FLUID RESERVOIR

Removal Procedure

1. Remove the fluid level switch connector. Refer to "Brake Fluid Level Switch" in this section.
2. Remove the reservoir.
 - Drain the brake fluid.
 - Remove the screw (1).
 - Remove the fluid reservoir using a flathead screwdriver (2).

Notice: Do not force one side strongly to prevent damage of reservoir when removing the reservoir.

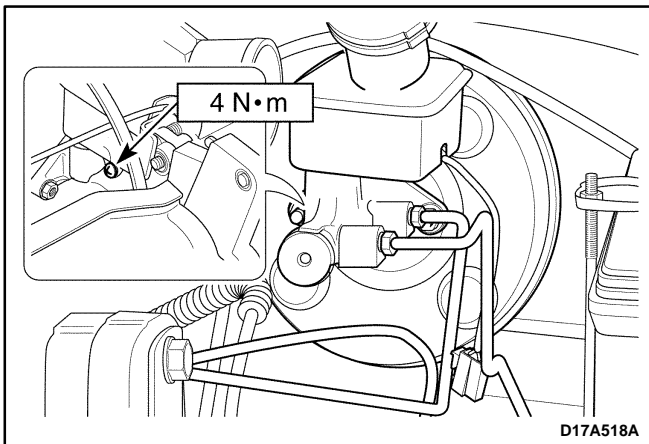

Installation Procedure

Important: Use only Daewoo recommended brake fluid.

1. Install the reservoir with the screw.

Tighten

Tighten the screw to 4 N·m (35 lb-ft).

2. Install the fluid level switch connector. Refer to "Brake Fluid Level Switch" in this section.
3. Add brake fluid.
4. Bleed the brake system. Refer to *Section 4A, Hydraulic Brakes*.

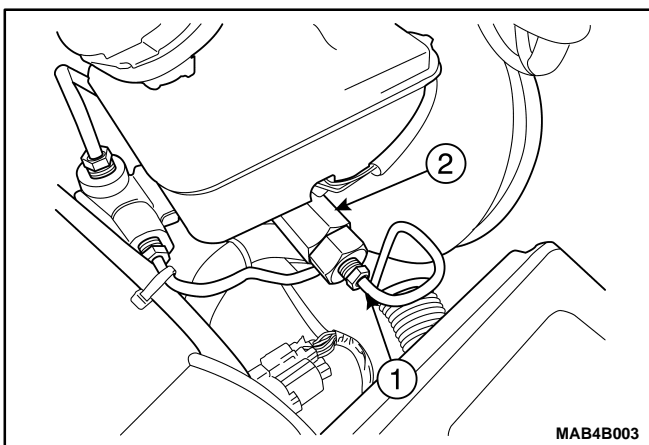

PROPORTIONING VALVE (FOR VEHICLE WITH THE NON-ABS BRAKING SYSTEM)

1. Remove the proportioning valve.
 - Loosen the brake pipe fittings-to-proportioning valve (1).
 - Remove the proportioning valve (2).
 - Plug the opening in the proportioning valve and brake pipe fitting to prevent fluid loss or contamination.

Notice: Brake fluid may damage paintwork, if spillage onto paintwork, wash with cold water immediately.

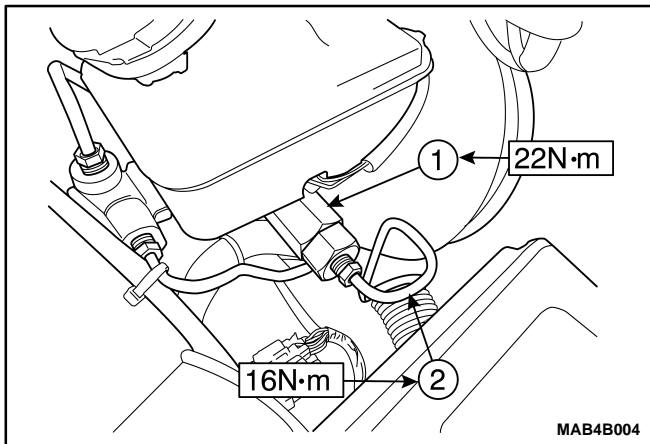

Installation procedure

1. Install the proportioning valve (1).

Tighten

Tighten the proportioning valve to 22 N•m (16 lb-ft).

2. Install the brake pipe fitting (2).

Tighten

Tighten the brake pipe fitting-to-proportioning valve to 16 N•m (12 lb-ft).

3. Bleed the brake system. Refer to *Section 4A, Hydraulic Brakes*.

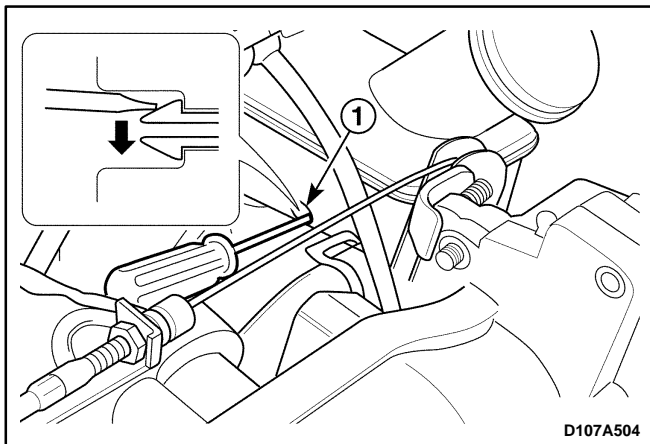

BRAKE FLUID LEVEL SWITCH

Removal procedure

1. Remove the vacuum hose from the power booster. Refer to *Section 4C, Power Booster*.
2. Remove the brake fluid level switch.
 - Remove the brake fluid level switch locking system by the flathead screwdriver (1).

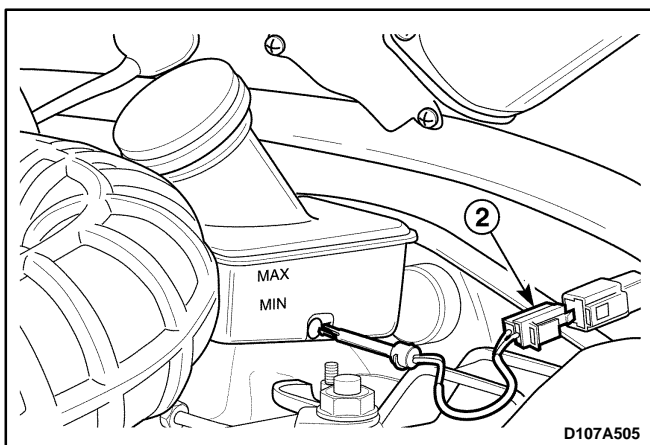

- Disconnect the electrical connector (2).

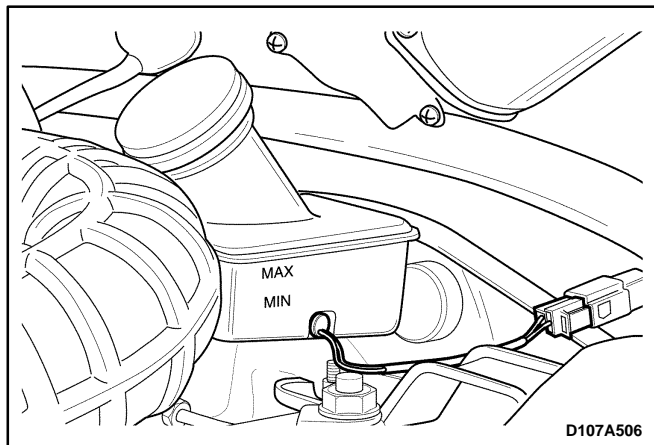

Installation procedure

1. Install the brake fluid level switch.
2. Connect the electrical connector.
3. Install the vacuum hose to the power booster. Refer to *Section 4C, Power Booster*.

UNIT REPAIR

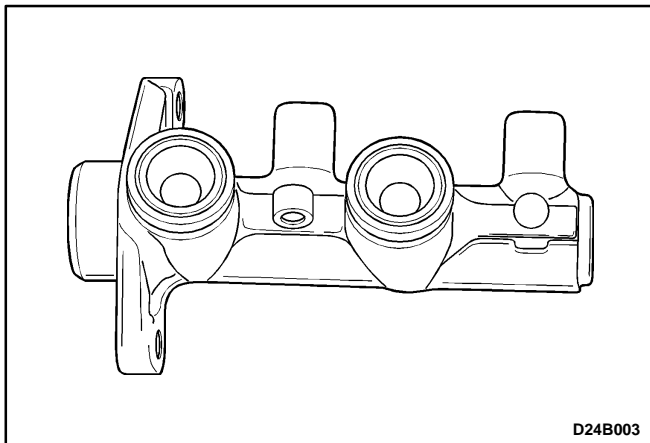
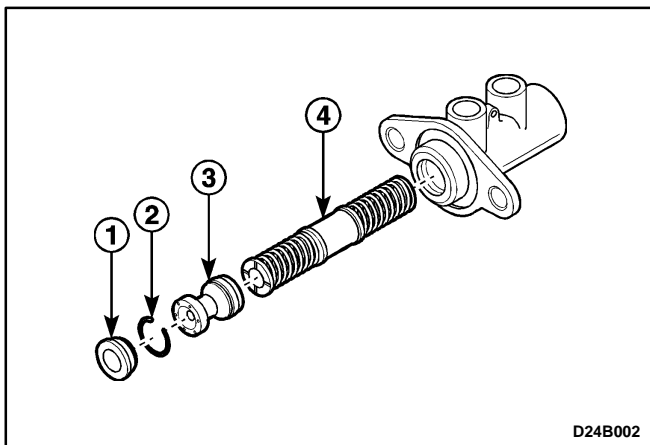
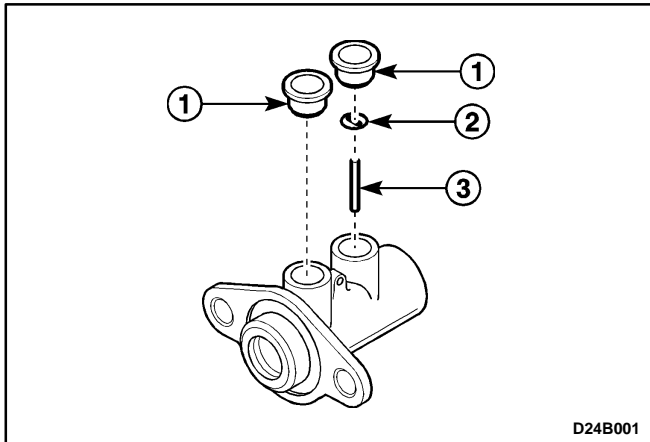

MASTER CYLINDER

(ABS Type Master Cylinder is Shown, Non-ABS Type Master Cylinder is Similar)

Disassembly Procedure

1. Remove the master cylinder. Refer to “Master Cylinder Assembly” in this section.
 2. Remove the brake fluid reservoir. Refer to “Brake Fluid Reservoir” in this section.
 3. Remove the reservoir seals (1).
 4. Remove the washer (2).
 5. Remove the stop pin (3).
 6. Remove the boot (1).
 7. Remove the retaining ring (2).
- Notice:** When removing the retaining ring, avoid damaging the piston or the cylinder wall.
8. Remove the primary piston (3).
 9. Carefully remove the secondary piston assembly and the spring from the master cylinder bore (4).

Assembly Procedure

1. Install the secondary piston assembly .
2. Install the stop pin.
3. Install the primary piston.
4. Install the retaining ring.
5. Install the boot.
6. Install the washer.
7. Install the reservoir seals.
8. Install the brake fluid reservoir. Refer to “Brake Fluid Reservoir” in this section.
9. Install the master cylinder. Refer to “Master Cylinder Assembly” in this section.
10. Raise and suitably support the vehicle.
11. Bleed the braking system. Refer to *Section 4A, Hydraulic Brakes*.
12. Lower the vehicle.

SPECIFICATIONS

GENERAL SPECIFICATIONS

Application		Unit	Description
Master Cylinder	Type	–	Tandem
	Bore Diameter	mm (in.)	20.64 (0.81)
Proportioning Valve	Cut-In Pressure	kPa (psi)	3,000(435.1)
	Pressure Ratio	–	0.25 : 30

FASTENER TIGHTENING SPECIFICATIONS

Application	N•m	Lb-Ft	Lb-In
Fluid Reservoir Screw	4	–	35
Master Cylinder Attaching Nuts	16	12	–
Brake Pipe Fittings to Master Cylinder	16	12	–
Brake Pipe Fittings to Proportioning Valve	16	12	–
Brake Pipe Fittings to Rear Wheel Cylinder	16	12	–
Brake Pipe Fittings to Front Caliper	16	12	–
Proportioning Valve	22	16	–